

STARPOINT Eyenut

Safety instructions

This safety instruction / declaration of the manufacturer has to be kept on file for the whole lifetime of the product.
Translation of the Original instructions



STARPOINT-eyenut **VRM** for bolts with min. quality class 10.9



RUD Ketten
Rieger & Dietz GmbH u. Co. KG
D-73428 Aalen/Germany
Tel. +49 7361 504-1371-1314-1527
Fax +49 7361 504-1460
www.rud.com
info@rud.com

RUD-Art.-Nr.: 8502512-EN / 06.012

EG-Konformitätserklärung

entsprechend der EG-Maschinenrichtlinie 2006/42/EG, Anhang II A und ihren Änderungen

Hersteller: **RUD Ketten
Rieger & Dietz GmbH u. Co. KG**
Friedensinsel
73432 Aalen

Hiermit erklären wir, dass die nachfolgend bezeichnete Maschine aufgrund ihrer Konzipierung und Bauart, sowie in der von uns in Verkehr gebrachten Ausführung, den grundlegenden Sicherheits- und Gesundheitsanforderungen der EG-Maschinenrichtlinie 2006/42/EG sowie den unten aufgeführten harmonisierten und nationalen Normen sowie technischen Spezifikationen entspricht.
Bei einer nicht mit uns abgestimmten Änderung der Maschine verliert diese Erklärung ihre Gültigkeit.

Produktbezeichnung: StarPoint Ringmutter
VRM

Folgende harmonisierten Normen wurden angewandt:

EN 12100-1	EN 12100-2
EN 14121-1	EN 1677-1
_____	_____
_____	_____

Folgende nationalen Normen und technische Spezifikationen wurden außerdem angewandt:

BGR 500, KAP2.8	_____
_____	_____
_____	_____

Für die Zusammenstellung der Konformitätsdokumentation bevollmächtigte Person:
Reinhard Smetz, RUD Ketten, 73432 Aalen

Aalen, den 29.12.2009 Dr. Ing. Rolf Sinz, (Prokurist/QMB)
Name, Funktion und Unterschrift Verantwortlicher

EC-Declaration of conformity

According to the EC-Machinery Directive 2006/42/EC, annex II A and amendments

Manufacturer: **RUD Ketten
Rieger & Dietz GmbH u. Co. KG**
Friedensinsel
73432 Aalen

We hereby declare that the equipment sold by us because of its design and construction, as mentioned below, corresponds to the appropriate, basic requirements of safety and health of the corresponding EC-Machinery Directive 2006/42/EC as well as to the below mentioned harmonized and national norms as well as technical specifications.
In case of any modification of the equipment, not being agreed upon with us, this declaration becomes invalid.

Product name: STARPOINT Eye nut
VRM

The following harmonized norms were applied:

EN 12100-1	EN 12100-2
EN 14121-1	EN 1677-1
_____	_____
_____	_____

The following national norms and technical specifications were applied:

BGR 500, KAP2.8	_____
_____	_____
_____	_____

Authorized person for the configuration of the declaration documents:
Reinhard Smetz, RUD Ketten, 73432 Aalen

Aalen, 29.12.2009 Dr. Ing. Rolf Sinz, (Prokurist/QMB)
Name, function and signature of the responsible person

User instructions

- Reference should be made to German Standards accord. BGR 500 or other country specific statutory regulations and inspections are to be carried out by competent persons only.
- Before installing and every use, inspect visually RUD lifting points, paying particular attention to any evidence of corrosion, wear and weld cracks and deformations. Please ensure compatibility of bolt thread and tapped hole.
- STARPOINT-eyenuts should only be used with bolts or threaded studs with a min. quality class 10.9. **Non certified bolts or threaded studs are not allowed.** The material construction to which the lifting point will be attached should be of adequate strength to withstand forces during lifting without deformation.
- The lifting points must be positioned on the load in such a way that movement is avoided during lifting.
 - For single leg lifts, the lifting point should be vertically above the centre of gravity of the load.
 - For two leg lifts, the lifting points must be equidistant to/or above the centre of gravity of the load.
 - For three and four leg lifts, the lifting points should be arranged symmetrically around the centre of gravity in the same plane.
- Load Symmetry:
The working load limit of individual RUD lifting points are calculated using the following formula and are based on symmetrical loading:

$$W_{LL} = \frac{G}{n \times \cos \beta}$$

W_{LL} = working load limit
 G = load weight (kg)
 n = number of load bearing legs
 β = angle of inclination of the chain to the vertical

The calculation of load bearing legs is as follows:

	symmetrical	asymmetrical
two leg	2	1
three / four leg	3	1

(see table 1)

6. A plane bolting surface must be guaranteed. The internal thread has to be 100 % engaged on the bolt thread. The threaded stud must guarantee that the plane area of the eyenut can completely flat down to the work piece.

7. For assembly and tighten we recommend using the suitable ring spanner.

When using the STARPOINT-eyenut perpendicular only, the WLL from table no. 1 can be used.

8. The STARPOINT-eyenut has to be adjustable through 360° when fitted. Adjust to direction of pull before attaching of the lifting means.

Attention: STARPOINT-eyenut are not suited for turning under load!



- All fittings connected to the STARPOINT-eyenut should be free moving. When connecting and disconnecting the lifting means (sling chain) pinches and impacts should be avoided. Damage of the lifting means caused by sharp edges should be avoided as well.
- To prevent unintended dismounting through shock loading, rotation or vibration, thread locking fluid such as Loctite (depending on the application, please pay attention to the manufacturer's instruction) should be used to secure the nut.

For lifting points which remains on the construction we basically recommend to secure with liquid locking device.

Attention: Body must still be turnable!

11. Effects of temperature:

Starpoint nuts can be used in a temperature range of -40°C to max 100°C (-40°F up to 210°F).

12. RUD-Lifting points must not be used under chemical influences such as acids, alkaline solutions and vapours e.g. in pickling baths or hot dip galvanising plants. If this cannot avoided, please contact the manufacturer indicating the concentration, period of penetration and temperature of use.

13. The places where the lifting points are fixed should be marked with colour.

14. After fitting, an annual inspection or sooner if conditions dictate should be undertaken by a competent person examining the continued suitability. Also after damage and special occurrences.

Inspection criteria concerning paragraphs 2 and 14:

- Ensure tightness
- The plane area of the eyenut must properly flat down on the work piece.
- The lifting point should be complete.
- The working load limit and manufacturers stamp should be clearly visible.
- Deformation of the component parts such as body and bolt.
- Mechanical damage, such as notches, particularly in high stress areas.
- Wear should be no more than 10 % of cross sectional diameter.
- Evidence of corrosion.
- Evidence of cracks.
- Damage to the bolt, nut and/or thread.
- The body of the STARPOINT-eyenut must be free to rotate.

A non-adherence to this advice may result damages of persons and materials!

Method of lift										
Number of legs	1	1	2	2	2	2	2	3 and 4	3 and 4	3 and 4
Angle of inclination β	0°	90°	0°	90°	0-45°	45-60°	unsymm.	0-45°	45-60°	unsymm.
Factor		1		2	1.4	1	1	2.1	1.5	1
Type	STARPOINT VRM - Max weight of load in metric-tonnes, bolted and adjusted to the direction of pull									
VRM-M 6	0.5 t	0.1 t	1 t	0.2 t	0.14 t	0.1 t	0.1 t	0.21 t	0.15 t	0.1 t
VRM-M 8	1 t	0.3 t	2 t	0.6 t	0.42 t	0.3 t	0.3 t	0.63 t	0.45 t	0.3 t
VRM-M 10	1 t	0.4 t	2 t	0.8 t	0.56 t	0.4 t	0.4 t	0.84 t	0.6 t	0.4 t
VRM-M 12	2 t	0.75 t	4 t	1.5 t	1.0 t	0.75 t	0.75 t	1.6 t	1.12 t	0.75 t
VRM-M 16	4 t	1.5 t	8 t	3 t	2.1 t	1.5 t	1.5 t	3.15 t	2.25 t	1.5 t
VRM-M 20	6 t	2.3 t	12 t	4.6 t	3.22 t	2.3 t	2.3 t	4.83 t	3.45 t	2.3 t
VRM-M 24	8 t	3.2 t	16 t	6.4 t	4.48 t	3.2 t	3.2 t	6.7 t	4.8 t	3.2 t
VRM-M 30	12 t	4.5 t	24 t	9 t	6.3 t	4.5 t	4.5 t	9.4 t	6.7 t	4.5 t

Table 1

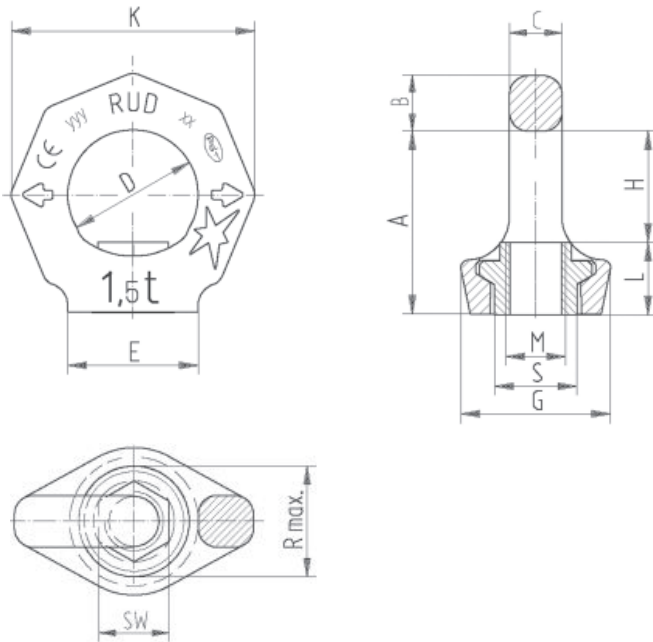

Type	WLL weight (kg)	A	B	C	D Ø	E Ø	G	H	K	L	M	Rmax	S Ø	SW	reference
VRM-M 6	0.1 t 0.06	28	9	7	20	23	28	16	37	11	M 6	16	13	9	7900786
VRM-M 8	0.3 t 0.1	34	11	8.5	25	25	28	20	47	14	M 8	20	16	12	7992989
VRM-M10	0.4 t 0.1	34	11	8.5	25	25	28	20	47	14	M10	20	16	12	7990311
VRM-M12	0.75 t 0.2	42	13	10	30	30	34	25	56	17	M12	24	20	14	7990312
VRM-M16	1.5 t 0.3	51	15	14	35	35.5	40	30	65	21	M16	30	22	19	7990314
VRM-M20	2.3 t 0.5	57	17	16	40	40	50	34	75	23	M20	37	29	24	7990315
VRM-M24	3.2 t 0.9	69	21	19	48	50	60	40	90	29	M24	45	35	30	7990316
VRM-M30	4.5 t 1.5	86	26	24	60	60	75	52	112	34	M30	56	44	36	7993008
VRM-M 6	0.1 t 0.06	1 ¹ / ₁₆ "	1 ¹ / ₃₂ "	9/ ₃₂ "	3/ ₄ "	29/ ₃₂ "	1 ¹ / ₈ "	5/ ₈ "	17/ ₁₆ "	7/ ₁₆ "	M 6	5/ ₈ "	1/ ₂ "	11/ ₃₂ "	7900786
VRM-M 8	0.3 t 0.1	1 ¹¹ / ₃₂ "	7/ ₁₆ "	11/ ₃₂ "	1"	1"	1 ⁷ / ₆₄ "	25/ ₃₂ "	17/ ₈ "	9/ ₁₆ "	M 8	25/ ₃₂ "	5/ ₈ "	15/ ₃₂ "	7992989
VRM-M10	0.4 t 0.1	1 ¹¹ / ₃₂ "	7/ ₁₆ "	11/ ₃₂ "	1"	1"	1 ⁷ / ₆₄ "	25/ ₃₂ "	17/ ₈ "	9/ ₁₆ "	M10	25/ ₃₂ "	5/ ₈ "	15/ ₃₂ "	7990311
VRM-M12	0.75 t 0.2	1 ²¹ / ₃₂ "	1/ ₂ "	25/ ₆₄ "	1 ³ / ₁₆ "	1 ³ / ₁₆ "	1 ¹¹ / ₃₂ "	1"	2 ³ / ₁₆ "	43/ ₆₄ "	M12	15/ ₁₆ "	25/ ₃₂ "	9/ ₁₆ "	7990312
VRM-M16	1.5 t 0.3	2"	19/ ₃₂ "	9/ ₁₆ "	1 ³ / ₈ "	1 ³ / ₈ "	1 ⁹ / ₁₆ "	1 ³ / ₁₆ "	2 ⁹ / ₁₆ "	53/ ₆₄ "	M16	1 ³ / ₁₆ "	7/ ₈ "	3/ ₄ "	7990314
VRM-M20	2.3 t 0.5	2 ¹ / ₄ "	43/ ₆₄ "	5/ ₈ "	1 ⁹ / ₁₆ "	1 ⁹ / ₁₆ "	1 ³¹ / ₃₂ "	1 ¹¹ / ₃₂ "	2 ¹⁵ / ₁₆ "	29/ ₃₂ "	M20	1 ²⁹ / ₆₄ "	1 ⁹ / ₆₄ "	15/ ₁₆ "	7990315
VRM-M24	3.2 t 0.9	2 ²³ / ₃₂ "	53/ ₆₄ "	3/ ₄ "	1 ⁷ / ₈ "	1 ³¹ / ₃₂ "	2 ³ / ₈ "	1 ⁹ / ₁₆ "	3 ⁹ / ₁₆ "	1 ⁹ / ₆₄ "	M24	1 ²⁵ / ₃₂ "	1 ³ / ₈ "	1 ³ / ₁₆ "	7990316
VRM-M30	4.5 t 1.5	3 ³ / ₈ "	1 ¹ / ₃₂ "	15/ ₁₆ "	2 ³ / ₈ "	2 ³ / ₈ "	2 ¹⁵ / ₁₆ "	2 ¹ / ₁₈ "	4 ¹³ / ₃₂ "	1 ¹¹ / ₃₂ "	M30	2 ³ / ₁₆ "	1 ³ / ₄ "	1 ¹³ / ₃₂ "	7993008

Table 2

Method of lift										
Number of legs	1	1	2	2	2	2	2	3 and 4	3 and 4	3 and 4
Angle of inclination β	0°	90°	0°	90°	0-45°	45-60°	unsymm.	0-45°	45-60°	unsymm.
Factor		1		2	1.4	1	1	2.1	1.5	1
Type	STARPOINT VRM - Max weight of load in lbs, bolted and adjusted to the direction of pull									
VRM-M 6	1100 lbs	220 lbs	2200 lbs	440 lbs	308 lbs	220 lbs	220 lbs	462 lbs	330 lbs	220 lbs
VRM-M 8	2200 lbs	660 lbs	4400 lbs	1320 lbs	925 lbs	660 lbs	660 lbs	13850 lbs	990 lbs	660 lbs
VRM-M 10	2200 lbs	880 lbs	4400 lbs	1760 lbs	1235 lbs	880 lbs	880 lbs	1850 lbs	1320 lbs	880 lbs
VRM-M 12	4400 lbs	1650 lbs	8800 lbs	3300 lbs	2200 lbs	1650 lbs	1650 lbs	3460 lbs	2470 lbs	1650 lbs
VRM-M 16	8800 lbs	3300 lbs	17640 lbs	6610 lbs	4630 lbs	3300 lbs	3300 lbs	6940 lbs	4960 lbs	3300 lbs
VRM-M 20	13250 lbs	5070 lbs	26500 lbs	10140 lbs	7100 lbs	5070 lbs	5070 lbs	10650 lbs	7600 lbs	5070 lbs
VRM-M 24	17630 lbs	7050 lbs	35260 lbs	14100 lbs	9880 lbs	7050 lbs	7050 lbs	14800 lbs	10580 lbs	7050 lbs
VRM-M 30	26455 lbs	9920 lbs	52910 lbs	19840 lbs	13888 lbs	9920 lbs	9920 lbs	20832 lbs	14880 lbs	9920 lbs

Table 3