

# DL1800A, DL2000A, DL2500A & DL3200A

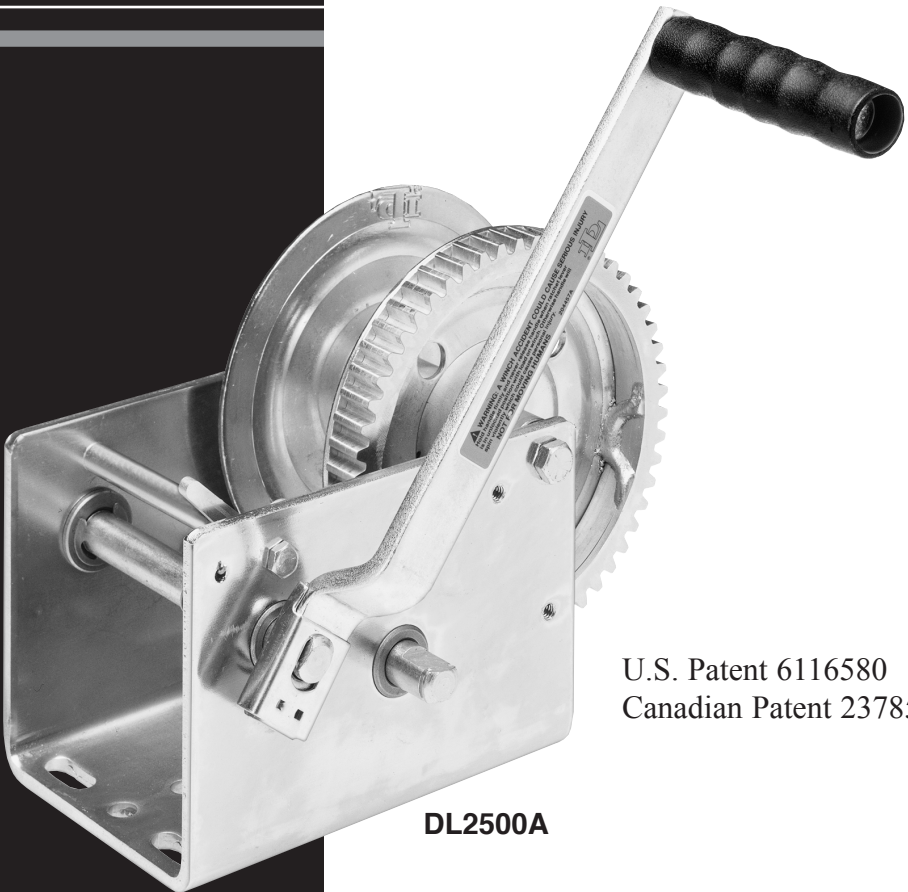

## PULLING WINCHES



U.S. Patent 6116580  
Canadian Patent 2378538

**DL2500A**



A Dependable Company Since 1886  
**DUTTON-LAINSON COMPANY**  
Hastings, NE 68902 U.S.A • Tel 402-462-4141 • Fax 402-460-4612  
E-mail [dlsales@dutton-lainson.com](mailto:dlsales@dutton-lainson.com) • Web Site [www.dutton-lainson.com](http://www.dutton-lainson.com)

**MADE IN  
USA**

**ISO 9001: 2008 REGISTERED Q.M.S.**

**⚠ WARNING** READ INSTRUCTIONS CAREFULLY BEFORE ATTEMPTING TO INSTALL, OPERATE OR SERVICE THIS WINCH. FAILURE TO COMPLY WITH INSTRUCTIONS COULD RESULT IN SERIOUS OR FATAL INJURY. RETAIN THESE INSTRUCTIONS FOR FUTURE REFERENCE.



## IMPORTANT SAFETY INFORMATION

- This winch is built for multi-purpose hauling and pulling operations. It is not recommended for lifting applications. For lifting, use a self-locking winch. DL winches are not to be used as hoists for lifting, supporting or transporting people, or for loads over areas where people could be present.
- Respect this winch. High forces are created when using a winch, creating potential safety hazards. It should be operated and maintained in accordance with instructions. Never allow children or anyone who is not familiar with the operation of the winch to use it.
- Maintain a firm grip on the winch handle at all times, and never release the handle when ratchet lever is in unlocked position with a load on the winch. Otherwise, handle will spin violently, which could cause personal injury.
- Check for proper ratchet operation on each use of the winch. Do not use if damaged. Seek immediate repairs.
- Never use the winch handle as a convenient handle for pulling or maneuvering the entire trailer or other equipment. Never pull on the winch handle against a locked ratchet.
- Never exceed rated capacity. Excess load may cause premature failure and could result in serious personal injury. This winch is rated with three layers of line on the hub. Using more layers of line or a large hub increases the load on the winch.
- Never apply load on winch with cable or rope fully extended. Keep at least three full turns of cable or rope on the reel.
- Secure load properly. When winching operation is complete, do not depend on winch to support load.
- Operate with hand power only. This winch should not be operated with a motor of any kind. If the winch cannot be cranked easily with one hand, it is probably over-loaded.

## WINCH MOUNTING AND CABLE ATTACHMENT

— For maximum strength and safety, (and compliance with SAE Standard J1853) this winch should be mounted with three  $\frac{3}{8}$ " or M10 bolts, washers, and lock washers. (Use grade 5 or 8 for DL2500A, 2500AB, DL3200A & 3200AB). See parts drawing.

Select a winch line with breaking strength at least 1-1/2 times the winch rating and a hook 1-1/2 times stronger than the line. If steel cable is

selected, the optional reel with large hub may extend cable life. (The above combination meets SAE Standard J1853 for boat trailer winches).

Attach cable or rope by either method described in sketch. If nylon strap is used, it should have a loop sewn in one end and be attached using a  $\frac{3}{8}$ " x  $3\frac{1}{4}$ " long bolt and locknut. Use a locknut, not a nut and lockwasher. Insert bolt through slots in both reel sideplates so that nut is on gear side. Tighten only until snug with bolt in bottom of slot next to reel hub.

## OPERATING INSTRUCTIONS

— Attach winch handle securely to primary drive shaft (upper or low speed shaft). Make sure that handle clip engages with groove in drive shaft. Wind line on winch reel by turning winch handle in counterclockwise direction with ratchet lever in "down" position. The ratchet should produce a loud, sharp, clicking noise. Make sure that ratchet lever is in "down" position and holding load before winch handle is released. To unwind or reel out line, securely grip winch handle and apply force in counterclockwise direction so that ratchet lever can easily be moved to "up" position. Carefully turn handle in clockwise direction. Do not lose control. If handle is attached to intermediate (lower or high speed) shaft, operate as described above, reversing clockwise and counterclockwise. The winch can be converted to wind line on to the underside of the reel. To do this, carefully examine ratchet assembly and remove it from winch. Do not

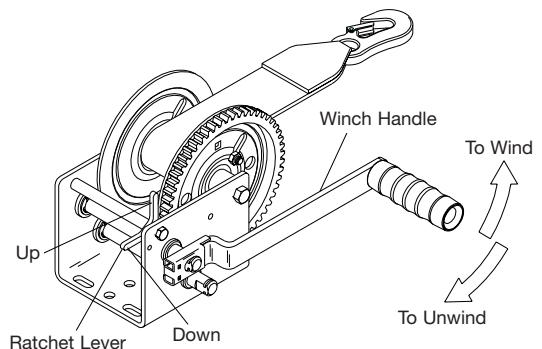

lose small parts. Turn the lever over and reassemble. Do not over tighten bolt. Check operation to insure the ratchet lever rotates fully without binding.

**WINCH MAINTENANCE** — This winch has been fully lubricated at the factory; but, for continued smooth performance and increased life, occasional greasing of gears and reel shaft and an occasional

drop of oil on drive shaft bearings are recommended. Keep winch in good working order. Damaged or severely-worn parts create unnecessary dangers and could result in personal injury or property damage.

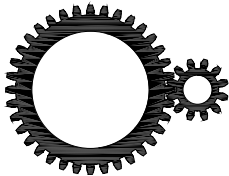

**DL1800A – 10.3:1/5.4:1**  
**DL2000A – 12.4:1/5.4:1**  
**DL2500A – 17.3:1/5.4:1**  
**DL3200A – 17.3:1/5.4:1**



**DL1800A – 1800 lbs/817 kg**  
**DL2000A – 2000 lbs/907 kg**  
**DL2500A – 2500 lbs/1134 kg**  
**DL3200A – 3200 lbs/1452 kg**

**CABLE**

**DL1800A – 9/32" x 58 ft (7 mm x 17.9 m)**  
**DL2000A – 9/32" x 58 ft (7 mm x 17.9 m)**  
**DL2500A – 5/16" x 47 ft (8 mm x 14.2 m)**  
**DL3200A – 3/8" x 30 ft (9 mm x 10.1 m)**

**ENGLISH – DECLARATION OF CONFORMITY** - Dutton-Lainson Company, Hastings, NE 68902-0729 U.S.A. manufactures and declares that the winch identified above fulfills all relevant provisions of the Directive 2006/42/EC. The technical file may be obtained from the persons listed below.

**DEUTSCH – KONFORMITÄTSERKLÄRUNG** - Dutton-Lainson Company, Hastings, NE 68902-0729, USA, der Hersteller der Winde, erklärt, dass die oben angegebene Winde alle relevanten Bestimmungen der Richtlinie 2006/42/EG erfüllt. Die technischen Unterlagen sind bei den nachfolgend aufgeführten Personen erhältlich.

**ITALIANO – DICHIARAZIONE DI CONFORMITÀ** - Il fabbricante, Dutton-Lainson Company, Hastings, NE 68902-0729 USA, dichiara che il verricello di cui sopra è conforme alle disposizioni della direttiva 2006/42/CE. Il fascicolo tecnico può essere richiesto agli individui indicati qui di seguito.

**PORTUGUÊS – DECLARAÇÃO DE CONFORMIDADE** - A empresa Dutton-Lainson Company, Hastings, NE 68902-0729, nos E.U.A., fabrica o guincho acima identificado e declara que este cumpre todas as provisões relevantes da Directiva 2006/42/CE. Poderá obter o processo técnico junto das pessoas indicadas abaixo.

**ESPAÑOL – DECLARACION DE HOMOLOGACION** - Dutton-Lainson Company, de Hastings, NE 68902-0729 EE.UU., fabrica y declara que el cabrestante arriba identificado satisface todas las provisiones pertinentes de la directriz 2006/42/EC. El archivo técnico puede obtenerse de las personas mencionadas a continuación.

**SVENSKA – FÖRSÄKRAN OM ÖVERENSSTÄMMELSE** - Dutton-Lainson Company, Hastings, Nebraska 68902-0729 U.S.A, tillverkar och försäkrar att denna vinsch överensstämmer med alla tillämpliga bestämmelser i Direktiv 2006/42/EC. Den tekniska filen kan erhållas från de personer, som upptas nedan.

**DANSK – OVERENSSTEMMELSESERKLÆRING** - Dutton-Lainson Company, Hastings, NE 68902-0729 USA fremstiller og erklærer, at skraldespillet identificeret ovenfor er i overensstemmelse med alle relevante krav i direktiv 2006/42/EU. Den tekniske fil kan rekvireres gennem de nedennævnte personer.

**SUOMI – VAATIMUSTENMUKAISUUSVAKUUTUS** - Dutton-Lainson Company, osoite Hastings, NE 68902-0729 U.S.A, vakuuttaa tämän vintturin valmistajana, että tämä vintturi noudattaa direktiivin 2006/42/EY olennaisia määräyksiä. Tekniset tiedot on saatavissa alla ilmoitetuilla henkilöillä.

**NORSK – SAMSVARERKLÆRING** - Dutton-Lainson Company, Hastings, NE 68902-0729 U.S.A. produserer og erklærer at vinsjen angitt ovenfor oppfyller alle relevante krav i direktivet 2006/42/EC. Den tekniske filen kan skaffes fra personene som er opplistet nedenfor.

**NEDERLANDS – VERKLARING VAN OVEREENSTEMMING** - Dutton-Lainson Company, Hastings, NE 68902-0729 VS, fabrikant, verklaart dat de bovengenoemde lier voldoet aan alle betreffende bepalingen van richtlijn 2006/42/EC. Het technische bestand kan bij de hierna vermelde personen worden aangevraagd.

**FRANÇAIS – DÉCLARATION DE CONFORMITÉ** - Dutton-Lainson Company, Hastings, NE 68902-0729 U.S.A. construit le treuil mentionné ci-dessus et déclare qu'il répond à toutes les dispositions applicables de la Directive 2006/42/CE. Le dossier technique peut être obtenu auprès des personnes indiquées ci-dessous.

**ΕΛΛΗΝΙΚΑ – ΔΗΛΩΣΗ ΣΥΜΜΟΡΦΩΣΗΣ** - Η Dutton-Lainson Company, Hastings, NE 68902-0729 U.S.A. κατασκευάζει και δηλώνει ότι το βαρούλκο που καθορίζεται παραπάνω πληροί όλες τις σχετικές διατάξεις της Οδηγίας 2006/42/ΕΚ. Ο τεχνικός φάκελος είναι διαθέσιμος από τα άτομα τα οποία αναγράφονται παρακάτω.

Hastings, NE USA  
April 5, 2011

*Ron Hease*  
Senior Vice President  
Dutton-Lainson Company

Peter Munday  
Bainbridge International Limited  
8 Flanders Park, Hedge End, Southampton, Hampshire,  
SO30 2FZ UK

**ENGLISH**-To obtain a copy of the warranty in English, send a self-addressed envelope to: Dutton-Lainson Company; P.O. Box 729; Hastings NE 68902-0729; U.S.A.

**DEUTSCH**-Wenn Sie eine deutsche Kopie der Garantibestimmungen erhalten möchten, senden Sie bitte einen adressierten Rückumschlag an: Dutton-Lainson Company; P.O.Box 729; Hastings NE 68902-0729; USA

**ITALIANO**-Per ricevere una copia della garanzia in italiano, inviare una busta riportante il proprio indirizzo a: Dutton-Lainson Company, P.O. Box 729, Hastings NE 68902-0729 USA.

**PORTUGUÊS**-Para obter uma cópia da garantia em português, envie um envelope com a sua morada para: Dutton-Lainson; P. O. Box 729; Hastings NE 68902-0729; E.U.A.

**ESPAÑOL**-Para obtener una copia de la garantía en español, envíe un sobre con su dirección impresa a: Dutton-Lainson Company, P.O. Box 729; Hastings NE 68902-0729 EE.UU.

**SVENSKA**-För att erhålla ett exemplar av garantin på svenska skicka ett adresserat kuvert till: Dutton-Lainson Company, P.O.Box 729, Hastings NE 68902-0729 U.S.A.

**DANSK**-Man kan få garantibeviset på dansk ved at sende en svarkuvert til: Dutton-Lainson Company, P.O. Box 729, Hastings NE 68902-0729, USA.

**SUOMI**-Takuutodistuksesta saa suomenkielisen kopion lähettämällä riittävällä postimaksulla ja vastaanottajan osoitteella varustetun kirjekuoren osoitteeseen Dutton-Lainson Company, P.O. Box 729, Hastings NE 68902-0729, USA.

**NORSK**-En kopi av denne garantien på norsk fås ved å sende en konvolutt med eget navn og adresse, til Dutton-Lainson Company, P.O. Box 729, Hastings NE 68902-0729, USA

**NEDERLANDS**-Voor een exemplaar van de garantie in het Nederlands dient u een aan u zelf geadresseerde enveloppe te zenden naar: Dutton-Lainson Company; P.O. Box 729; Hastings NE 68902-0729; U.S.A.

**FRANÇAIS**-Pour obtenir une copie de la garantie en français, envoyer une enveloppe à votre nom et adresse à : Dutton-Lainson Company; P.O. Box 729; Hastings NE 68902-0729; U.S.A.

**ΕΛΛΗΝΙΚΑ**-Για να λάβετε ένα αντίγραφο της εγγύησης στα Ελληνικά, στείλτε ένα φάκελο εσωκλείοντας τα ταχυδρομικά τεύχη αποστολής στην εξής διεύθυνση: Dutton-Lainson Company, P.O.Box 729, Hastings NE 68902-0729 U.S.A.



# DL1800A, DL2000A, DL2500A, DL3200A

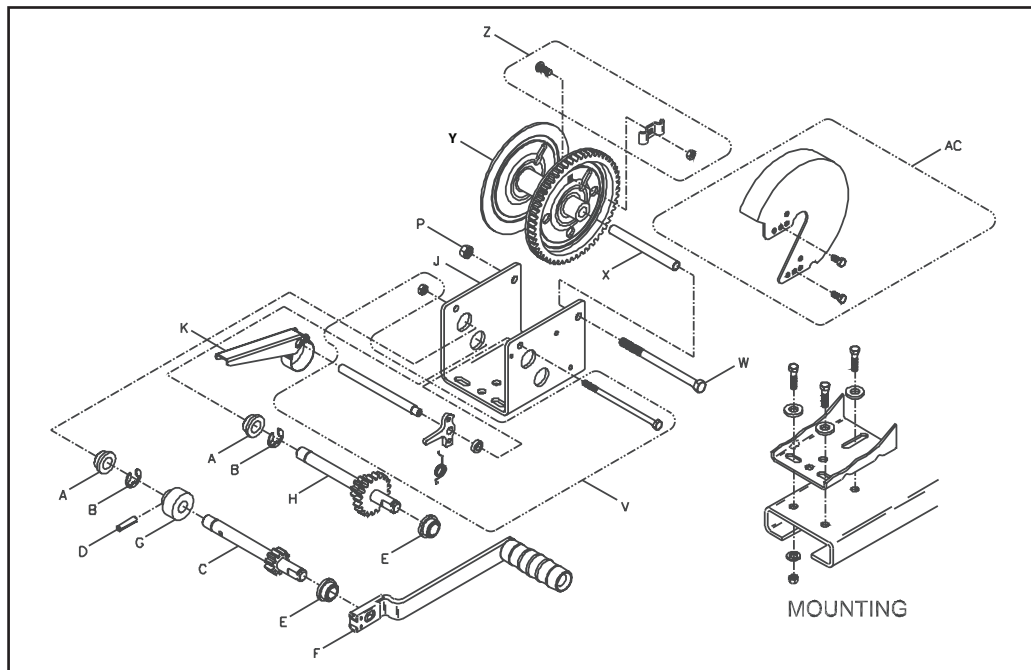

Ref	Description	Part No.
A	Bushing (2)	204009
B	E-Ring (2)	205116
C	Drive Shaft - DL1800A, 2000A, 2500A	304726
C	Drive Shaft - DL3200A	304736
C	Dr. Shaft w/Hole - DL1800A thru 2500A	304780
C	Dr. Shaft w/Hole - DL3200A	304787
D	Pin (Optional)	207255
E	Bushing (2)	204012
F	Handle	5703301
G	Drum (Optional)	404910
H	Drive Shaft - DL1800A	304732
H	Drive Shaft - DL2000A	304733
H	Drive Shaft - DL2500A	304727
H	Drive Shaft - DL3200A	304737
H	Drive Shaft - DL2500A, Spec. Opt.	304781
J	Base - DL1800A	404879*
J	Base - DL2000A	404880*
J	Base - DL2500A	404875*
J	Base - DL3200A	404907*

Ref	Description	Part No.
K	Brake Band/Handle Assy.	304810
P	Locknut	204803
V	Ratchet Kit	5704754
W	Reel Shaft - DL1800A	205127
W	Reel Shaft - DL2500A, 2000A	204804
W	Reel Shaft - DL3200A	205335
X	Spacer (Reel)	204808
Y	Reel (1-1/8" Hub) - DL1800A, 2000A	304730*
Y	Reel (2-1/2" Hub) - DL1800A, 2000A, Opt.	304755*
Y	Reel (1-1/8" Hub) - DL2500A	304728*
Y	Reel (2-1/2" Hub) - DL2500A, Opt.	304783*
Y	Reel (1-1/8" Hub) - DL3200A	304735*
Y	Reel (2-1/2" Hub) - DL3200A, Opt.	304788*
Z	Rope Clamp Kit	5243506
AC	Gear Cover - DL1800A, DL2000A, DL2500A, Opt., Bronze	5240387
AC	Gear Cover - DL1800A, DL2000A, DL2500A, Opt., Plated	5240403

\*Specify color when ordering

To order replacement parts:

### Dutton-Lainson Company

www.dlco.com

Tel: 800-569-6577

Fax: 402-460-4612

e-mail: DLsales@dutton-lainson.com

### In Europe Contact

#### Bainbridge International Ltd.

8 Flanders Park

Hedge End

Southampton

Hampshire SO30 2FZ

UK

Tel: +44 (0) 1489-776050

Fax: +44 (0) 1489-776055

www.bainbridgmarine.co.uk

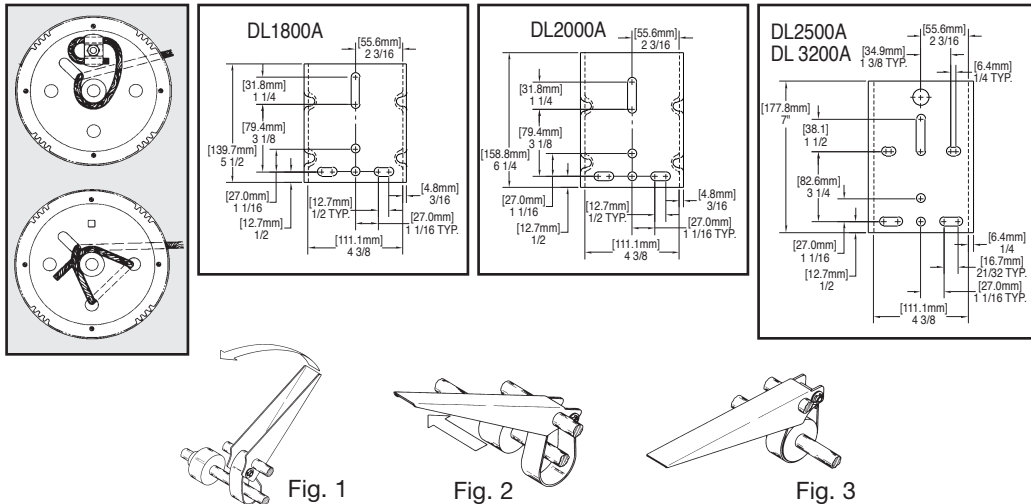

### ENGLISH – For Brake Equipped Winches: Initial Use

- NOTE:** The hand brake has been shipped in a retracted position to eliminate the possibility of damage during shipping. It may be quickly positioned for operation as follows:
1. Rotate the brake handle back from the forward position in FIG. 1 to the nearly horizontal position in FIG. 2.
  2. Slide the brake assembly sideways until the band can be guided around the drum. The band should not overhang the drum on either side.
  3. Lock the handle in place by pushing it down to the fully horizontal position in FIG. 3. The brake assembly will now stay in place and is ready to use.

### DEUTSCH – Mit Bremse ausgerüstete Winden: Inbetriebnahme

- HINWEIS:** Die Handbremse wird in zurückgezogener Stellung versandt, um Schäden während des Transports zu vermeiden. Sie kann auf folgende Weise problemlos in die Betriebsstellung gebracht werden:
1. Den Bremsengriff von der Vorwärtsstellung in Abb. 1 in die fast horizontale Stellung in Abb. 2 drehen.
  2. Die Bremseneinheit seitlich schieben, bis das Band um die Trommel herum geführt werden kann. Das Band darf nicht über die Kanten der Trommel herausragen.
  3. Den Griff in Stellung arretieren, indem er ganz in die horizontale Stellung (Abb. 3) gedrückt wird. Die Bremseneinheit bleibt jetzt in Stellung und ist betriebsbereit.

### ITALIANO – Verricelli con freno: approntamento del freno all'uso

- NOTA:** Il freno a mano viene spedito in posizione retratta per impedire il danneggiamento durante il trasporto. Approntare il freno per l'uso nel modo seguente:
1. Ruotare la manovella del freno verso il retro portandola dalla posizione illustrata nella FIG. 1 alla posizione quasi orizzontale illustrata nella FIG. 2.
  2. Far scorrere il gruppo del freno lateralmente fino a quando è possibile avvolgere il nastro intorno al tamburo. Accertarsi che il nastro non sporga dai lati del tamburo.
  3. Bloccare la manovella in posizione spingendola verso il basso fino a raggiungere la posizione orizzontale illustrata nella FIG. 3. Il gruppo del freno è ora in posizione ed è pronto all'uso.

### PORTUGUÊS – Para Guinchos Equipados com Travão - Uso Inicial

- NOTA:** O guincho manual é entregue em uma posição retráida para evitar a possibilidade de danos durante o transporte. Ele pode ser posicionado rapidamente para operação da seguinte forma:
1. Gire a alavanca do travão da posição para frente mostrada na FIG. 1 até a posição quase horizontal mostrada na FIG. 2.
  2. Deslize o conjunto do travão lateralmente até que a faixa possa ser guiada em torno do tambor. A faixa não deve sobressair do tambor em nenhum dos lados.
  3. Trave a alavanca no lugar empurrando-a para baixo até a posição completamente horizontal mostrada na FIG. 3. O conjunto do travão está posicionado e pronto para ser usado.

### ESPAÑOL – Para los cabrestantes que tienen frenos: Uso inicial

- NOTA:** El freno de mano ha sido embalado en la posición de retracción para evitar la posibilidad de daños durante el envío. Para ponerlo en funcionamiento, puede colocarse rápidamente en posición de la siguiente manera:
1. La manivela del freno está en la posición delantera como se muestra en la FIG. 1, gírela hacia atrás hasta que esté casi totalmente en posición horizontal como se muestra en la FIG. 2.
  2. Deslice el mecanismo de frenos lateralmente hasta que pueda guiar la banda y colarla alrededor del tambor. La banda no deberá sobresalir del tambor en cualquiera de sus lados.
  3. Asegure la posición de la manivela empujándola hasta que esté en posición totalmente horizontal como se muestra en la FIG. 3. El mecanismo de frenos ahora permanecerá en posición y está listo para ponerse en uso.

### SVENSKA – Vinschar utrustade med broms: Första användningen

- ANMÄRKNING:** Handbromsen levereras i tillbakadraget läge för att eliminera risken för skada under transport. Den kan snabbt ställas in för användning på följande sätt:
1. Vrid tillbaka bromshandtaget från framåt-positionen i FIG. 1 till den nästan horisontella positionen i FIG. 2.
  2. För bromsenheten på sidan tills bandet kan ledas runt trumman. Bandet ska inte hänga över trumman på någon av sidorna.
  3. Lås fast handtaget genom att trycka ner det till den helt horisontella positionen i FIG. 3. Bromsenheten sitter nu fast och är färdig för användning.

### DANSK – Til spil udstyret med bremse: Første brug

- BEMÆRK:** Ved forsendelsen er håndbremsen i tilbagetrækket stilling for at undgå risikoen for at beskadige den under transporten. Den kan hurtigt anbringes i arbejdsstilling på følgende måde:
1. Drej bremsehåndtaget tilbage fra fremadstillingen, der er vist i FIG. 1, til den næsten vandrette stilling, der er vist i FIG. 2.
  2. Lad bremsen glide til siden, indtil båndet kan føres omkring tromlen. Båndet bør ikke hænge ud over tromlen i nogen af siderne.
  3. Lås håndtaget på plads ved at trykke det ned i den helt vandrette stilling, der er vist i FIG. 3. Bremsen vil nu forblive på plads og er klar til brug.

### SUOMI – Jarrulla varustetut vintturin: Ensimmäinen käyttö

- HUOM!** Käsijarrun on lähetetty takaisinvedetyssä asennossa, jotta se ei vahingoittuisi kuljetuksen aikana. Se voidaan saada toimimaan nopeasti seuraavalla tavalla:
1. Kierrä jarruvipu takaisin eteenpäinasetnosta (KUV. 1) melkein vaakasuoraan asentoon (KUV. 2).
  2. Liu'uta jarruasennelman sivuttain kunnes jarruhihna voidaan ohjata rummun ympäri. Hihnan ei pidä riippua rummun yli kummallakaan puolella.
  3. Lukitse kampi paikalleen painamalla se alas täysin vaakasuoraan asentoon kuten KUV. 3. Jarruasennelman pysyy nyt paikallaan ja se on valmis käyttöön.

### NORSK – For vinsjer med bremse: Innledende bruk

- NB:** håndbremsen sendes i inntrukket stilling for å hindre faren for skade under forsendelsen. Den settes rask i arbeidsstilling slik:
1. Drei bremsehåndtaket tilbake fra fremre stilling, FIG.1, til nesten vannrett stilling, FIG.2.
  2. Skyv bremseenheten sideveis til båndet kan føres rundt trommelen. Båndet må ikke henge ut over trommelen på noen side.
  3. Lås håndtaket på plass ved å skyve det helt ned i vannrett stilling, FIG.3. Bremseenheten sitter nå på plass, klar til bruk.

### NEDERLANDS – Voor met een rem uitgeruste lieren: eerste gebruik

- OPMERKING:** De handrem is in de ingetrokken stand verzonden om beschadiging tijdens het vervoer te voorkomen. Hij kan als volgt snel voor bedrijf worden opgesteld:
1. Draai de remkruk vanuit de voorwaarts stand in AFB. 1 terug naar de bijna horizontale stand in AFB. 2.
  2. Schuif de remeenheid opzij tot de band om de trommel kan worden geleid. De band mag aan geen van beide kanten over de trommel hangen.
  3. Vergrendel de kruk op zijn plaats door hem omlaag te drukken tot de volledig horizontale stand zoals in AFB. 3. De remeenheid blijft nu op zijn plaats en is klaar voor gebruik.

### FRANÇAIS – Pour les treuils pourvus de frein : Utilisation initiale

- REMARQUE :** Le frein à main a été expédié en position rétractée pour éliminer la possibilité de dommages durant l'expédition. Il peut être positionné rapidement pour le fonctionnement comme suit :
1. Tourner la poignée du frein depuis la position avant, comme illustré à la FIG. 1, vers la position quasi-horizontale, comme illustré à la FIG. 2.
  2. Faire glisser l'ensemble de frein latéralement jusqu'à ce que la bande puisse être guidée autour du tambour. La bande ne doit pas être en porte-à-faux au-dessus du tambour d'un côté comme de l'autre.
  3. Bloquer la poignée en place en la poussant vers le bas jusqu'à la position pleinement horizontale, comme illustré à la FIG. 3. L'ensemble de frein restera maintenant en place et est prêt à usage.

### ΕΛΛΗΝΙΚΑ – Για βαρούλκα εξοπλισμένα με φρένο: Αρχική χρήση

- ΣΗΜΕΙΩΣΗ:** Το χειρόφρενο αποστέλλεται σε αποσυμμένη θέση για να εξελελυθεί το ενδεχόμενο ζημιάς κατά τη μεταφορά. Για τη γρήγορη επαναρρόφηση του σε θέση λειτουργίας πρέπει να:
1. Περιστρέψετε τη λαβή του φρένου από τη μπροστινή θέση της ΕΙΚ. 1 στη σχεδόν οριζόντια θέση της ΕΙΚ. 2.
  2. Μετακινήστε πλευρικά τη μονάδα φρένου έως ότου ο μόντας να μπει γύρω από το τύμπανο. Ο μόντας δεν πρέπει να προεξέχει από καμία πλευρά του τυμπάνου.
  3. Αποκαλύψτε τη λαβή στη θέση αυτή πιέζοντας την προς τα κάτω μέχρι την εντελώς οριζόντια θέση της ΕΙΚ. 3. Η μονάδα φρένου θα παραμείνει στη θέση της και είναι έτοιμη προς χρήση.