

S4824B and ST4824B

Available in Grid or Solid Top

COMPONENTS: 2-Shelf System

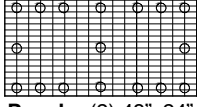
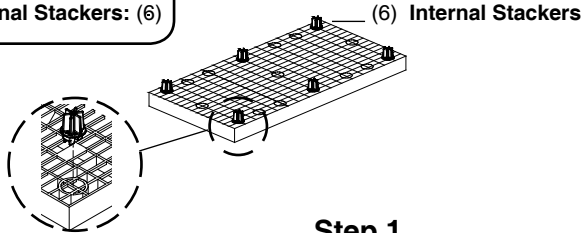

Panels: (2) 48"x24"
Legs: (6) 24"
Internal Stackers: (6)

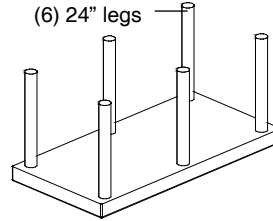

Step 1

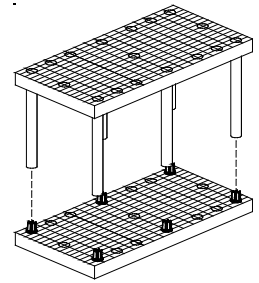

Step 2



Step 3

COMPONENTS: 3-Shelf System

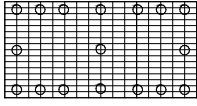

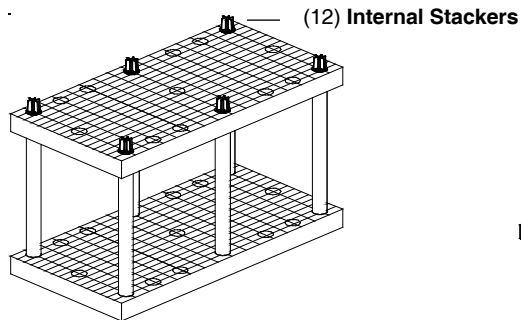
Panels: (3) 48"x24"
Legs: (12) 24"
Internal Stackers: (12)

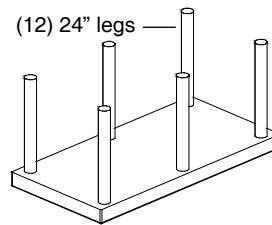

Step 1

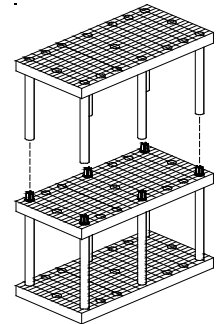

Step 2



Step 3

COMPONENTS: 4-Shelf System

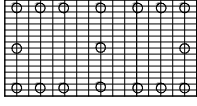

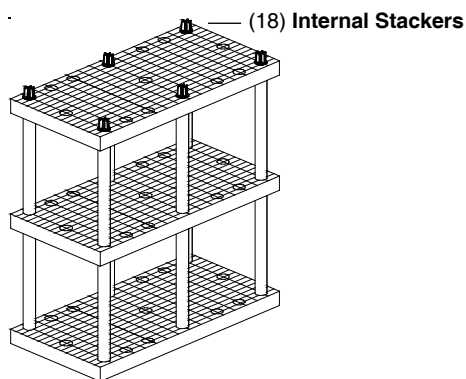
Panels: (4) 48"x24"
Legs: (18) 24"
Internal Stackers: (18)

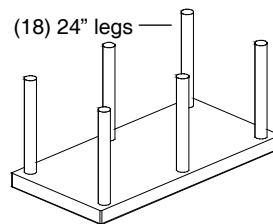

Step 1

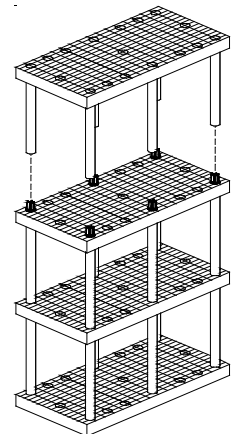

Step 2



Step 3

Step 1

Lay one of the shelf panels on the floor and insert leg stackers over outside sockets as shown.

Step 2

Invert the next level panel and insert 24" posts into the sockets as shown.

Step 3

Return panel with the 24" posts to upright position. Align posts over Leg Stackers and push all the way down until leg stackers are inserted into posts. Repeat steps 1 through 3 for multi-shelf configurations.