

Please read and save these instructions. Read carefully before attempting to assemble, install, operate or maintain the product described. Protect yourself and others by observing all safety information. Failure to comply with instructions could result in personal injury and/or property damage! Retain instructions for future reference.

Dayton® Fork and Platform Lifts

Description

Dayton Fork and Platform Lifts are designed for manual lifting, lowering, and transporting of loads on firm and level surfaces, including workshops, warehouses, stockrooms, receiving departments, throughout a plant, and wherever aisles and congested areas prevent the use of larger equipment.

Specifications for multiple types of lifts may be described in these Operating Instructions. During operation and maintenance, apply the relevant aspects for the Dayton Fork Lift or Platform Lift that you have purchased.

General Safety Information

Only authorized and trained operators should use this product.

CAUTION Never exceed the maximum capacity of the lift. Load must be evenly distributed and load center limits must not be exceeded.

CAUTION Use caution and be aware of pinch and crush points. Never place hands, feet, or objects under forks or platform. Never reach into moving parts.

CAUTION Do not use on inclines or uneven surfaces.

CAUTION Never leave the load unattended in a raised position.

CAUTION Transporting or lifting persons is not permitted.

Specifications

Model	Item	Load Cap.* (lbs.)	Max. Lifting Height	Min. Lifting Height	Platform/ Fork Length	Platform Width	Overall Length	Overall Width	Overall Height	Load Center**	Wheels
2MPT2	Platform Lift	1000	60"	5.75"	24"	24"	36"	25.5"	72"	13.5"	2 rigid, 2 swivel
2MPT3	Platform Lift	1000	68	5.75	24	24	40	25.5	80	13.5	2 rigid, 2 swivel
2MPT4	Platform Lift	1000	80	5.75	24	24	36	25.5	92	13.5	2 rigid, 2 swivel
2MPT5	Platform Lift	1000	60	5.75	30	32	44	32	72	16	2 rigid, 2 swivel
2MPT6	Platform Lift	1000	68	5.75	30	32	44	32	80	16	2 rigid, 2 swivel
2MPT7	Platform Lift	1000	80	5.75	30	32	44	32	92	16	2 rigid, 2 swivel
2MPT8	Fork Lift	1000	56	1	30	N/A	44	32	72	16	2 rigid, 2 swivel
2MPT9	Fork Lift	1000	64	1	30	N/A	44	32	80	16	2 rigid, 2 swivel
2MPU1	Fork Lift	1000	76	1	30	N/A	48	32	92	16	2 rigid, 2 swivel

(*) Maximum load capacity rating is for evenly distributed load.

(**) Read and understand load center restrictions.

Assembly

Your Dayton Fork or Platform Lift comes fully assembled. Inspect the lift for transit damage before operation. Refer to the replacement parts illustration and list in identifying parts. If damage is evident, notify delivering carrier immediately and file necessary claims.

Carefully read all manuals included with this product before putting into service. Never exceed the maximum capacity of the lift.

Fully read and follow the instructions for "Releasing air from the pump" in the Maintenance section of this manual before putting your Dayton lift into service.



Figure 1 Operation

Inspect the lift prior to each use. Discontinue use immediately if any problems, defects, or repair needs are discovered.

Pre-operation check list:

- Check the function of all moving parts, including rollers, wheels, axles, etc.
- If your lift is equipped with a parking brake, check the function of the parking brake.
- Check load chain for adjustment, tension, and wear.

ENGLISH

ESPAÑOL

FRANÇAIS

Dayton® Fork and Platform Lifts

Operation (Continued)

FOR LIFTS EQUIPPED WITH A PARKING BRAKE

Utilize the parking brake when placing loads, elevating loads, and when lift is not in use. Activate the brake by pressing the center pedal. Release the brake by pressing the lever to the left or right of the center pedal.

LIFTING A LOAD

Ensure that the load does not exceed the capacity of the lift, and that the load does not exceed the size of the forks or platform.

Roll the lift slowly up to the load and position the forks under the pallet/load until the back of the forks rests against the load, or manually place the load onto the platform or forks.

WARNING Do not load the lift in its raised position. The load must be evenly distributed across both forks or across the platform. The load center of gravity must not be exceeded.

Raise the load by pumping the foot pedal until it reaches the desired height.

MOVING A LOAD

The load should be in lowest possible position (while still maintaining clearance under the load) whenever transporting a load.

Travel at a steady speed, being mindful of the load and the floor conditions.

WARNING Do not operate the lift on gradients or uneven surfaces.

LOWERING A LOAD

Maneuver the load to its desired location and actuate the parking brake. Ensure there is nothing under the load, then turn the release valve counterclockwise to lower the load to the desired height. Turn the valve slowly to control the speed of descent.

Lower completely when not in use.

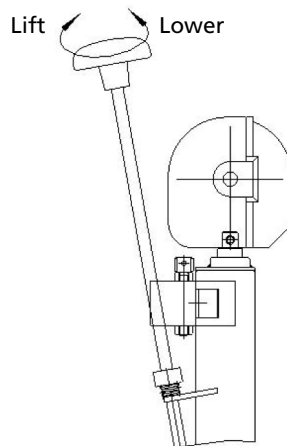

Figure 2

Maintenance

WARNING Remove loads before performing inspection or maintenance work. Only use genuine spare parts.

ADDING OIL

If the forks/platform won't raise to the rated height, you may need to add hydraulic fluid. Hydraulic fluid must be ISO VG32 or equivalent with a viscosity of 30cSt at 104°F (40°C). Mixing of different fluids is prohibited! Total oil volume is about 2 quarts. Check the oil level every six months.

NOTE: Waste oil must be disposed of in an environmentally-friendly way and in accordance with regulatory authorities.

LUBRICATION

Periodically lubricate all grease fittings according to the required maintenance schedule, or after any thorough cleaning that may excessively remove grease from critical lube points, using multipurpose lubricating grease ZG2# or 3#.

RELEASING AIR FROM THE PUMP

Air may enter the hydraulic oil during transportation or if the unit is tipped, such that the forks don't elevate immediately while pumping in the "raise" position. To release air from the pump, turn the release valve counterclockwise to the "lower" position and pump the foot pedal several times.

DAILY INSPECTION AND MAINTENANCE

Daily inspection of the lift can greatly reduce wear and maintenance. Special attention should be paid to the wheels, casters, and carriage rollers, inspecting for obstructions of any kind.

Models 2MPT2 thru 2MPT9, 2MPU1

Maintenance (Continued)

RECOMMENDED MAINTENANCE INTERVALS

The service life of your lift is limited. Worn parts must be replaced promptly.

DAILY:

- Check moving parts and operating controls for proper operation
- Check wheels and carriage rollers for wear or slop
- Check load chain for adjustment, tension, and wear
- Grease the chain if necessary

1 MONTH:

- Grease joints and bearings
- Check function and turning capability of wheels and rollers
- Check hydraulic system for leakage and full range of motion

3 MONTHS:

- Check hydraulic oil level with platform/forks fully lowered and the lift in a horizontal position
- Check the release valve adjustment
- Check all screw and bolt connections for tightness

1 YEAR:

- Check all parts for wear and replace defective parts as necessary
- Drain and replace hydraulic fluid
- Check readability of labels and safety warnings; replace if needed

⚠ WARNING *Do not attempt to repair lifts unless you are trained and authorized to do so. Serious injury could result.*

⚠ WARNING *These products may not be altered in any way without written permission from the manufacturer.*

Models 2MPT2 thru 2MPT9, 2MPU1

Troubleshooting Chart

Symptom	Possible Cause(s)	Corrective Action
Forks/platform doesn't raise, doesn't raise fully, or raises slowly	<ol style="list-style-type: none"> 1. Low hydraulic fluid level 2. Air in the hydraulic system 3. Release valve handle (54) is stuck in the wrong position (See Figure 5) 4. Load is too heavy. Overload release valve is being activated 5. Temperature is too low and the hydraulic oil has become too thick 	<ol style="list-style-type: none"> 1. Add approved hydraulic fluid as noted on page 2 (in Maintenance section) 2. Follow the procedure for releasing air from the pump on page 2 (in Maintenance section) 3. Unstick and turn release control handle (54) to the right position 4. Reduce load 5. Move truck to a warmer location
Forks/platform doesn't lower or doesn't lower fully	<ol style="list-style-type: none"> 1. Obstacle located under forks/platform, in fork mechanism, etc 2. The piston rod (1) or pump (5) has deformed from excess or uneven loading (See Figure 5) 3. Forks/platform was kept in the raised position for a long time, allowing the piston rod to rust or jam 4. Release valve handle set screw (53) has become loose (See Figure 5) 	<ol style="list-style-type: none"> 1. Use caution removing the obstacle 2. Replace the piston rod (1) or pump (5) (See Figure 5) 3. Lubricate the piston. Replace if necessary. Keep the forks/platform in the lowered position when not in use 4. Tighten the screw (53) (See Figure 5)
Forks/platform lower without turning the control lever to the "lower" position	<ol style="list-style-type: none"> 1. Oil impurities are preventing the release valve from fully closing 2. Some hydraulic components or seals are cracked or worn 3. Air in the hydraulic system 4. Release valve handle (54) is stuck in the wrong position (See Figure 5) 	<ol style="list-style-type: none"> 1. Drain and replace hydraulic fluid with approved fluid as noted on page 2 (in Maintenance section) 2. Inspect and replace components as needed 3. Follow the procedure for releasing air from the pump on page 2 (in Maintenance section) 4. Unstick and turn release control handle (54) to the right position (See Figure 5)

For Repair Parts, call 1-800-323-0620

24 hours a day – 365 days a year

Please provide following information:

- Model number
- Serial number (if any)
- Part description and number as shown in parts list

E
N
G
L
I
S
H

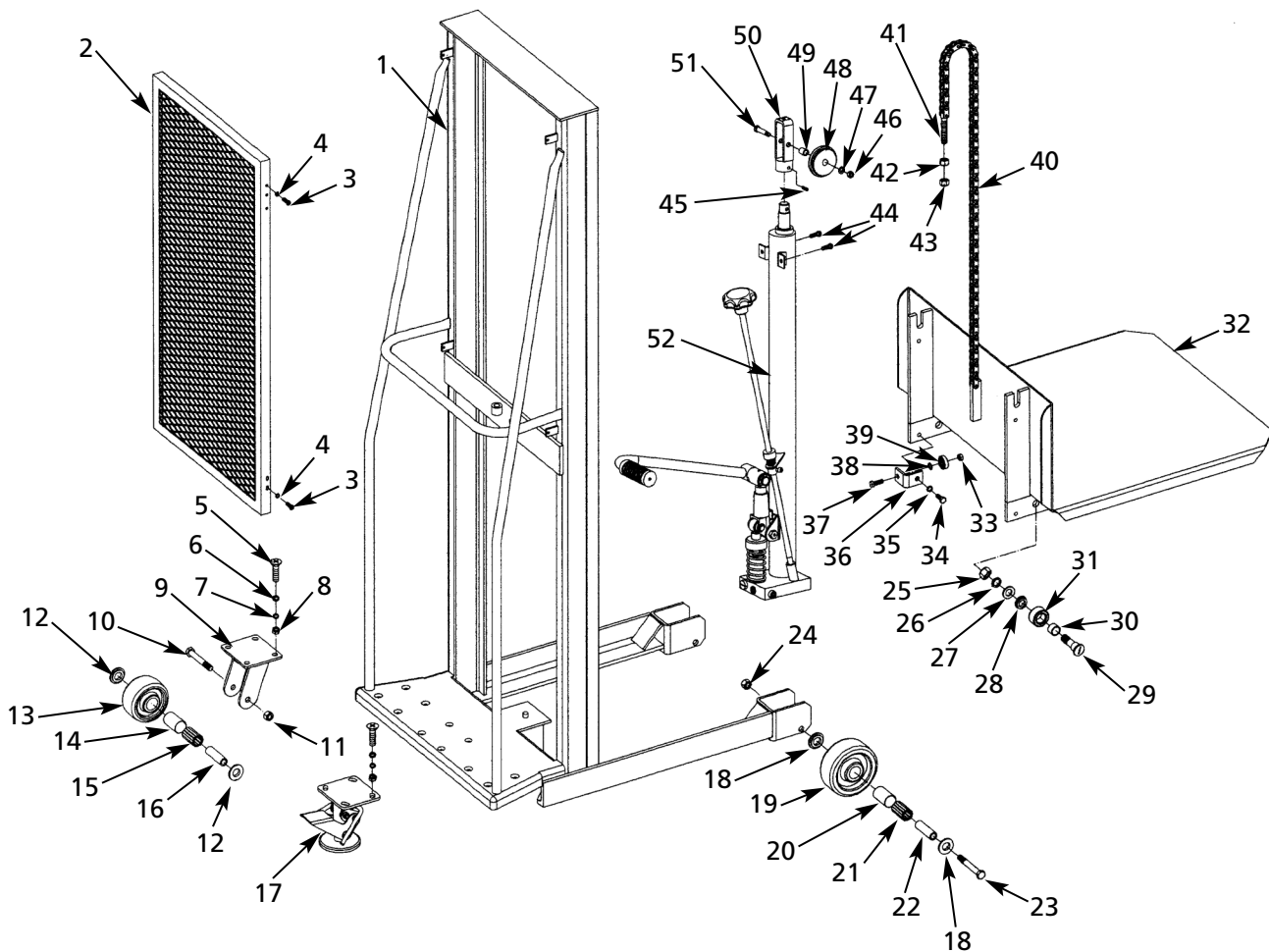

Figure 3 – Repair Parts Illustration for Platform Lift

Models 2MPT2 thru 2MPT7

Repair Parts List for Platform Lift

Ref. No.	Description	Part No.	Qty.	Ref. No.	Description	Part No.	Qty.
1	Mast	*	1	32	Platform:		
2	Protective Grill: (2MPT2, 2MPT5)	MH2MPT201G	1		(2MPT2-2MPT4)	MH2MPT206G	1
	(2MPT3, 2MPT6)	MH2MPT301G	1		(2MPT5-2MPT7)	MH2MPT501G	1
	(2MPT4, 2MPT7)	MH2MPT401G	1		Side Roller Kit	MH2MPT207G	
3	Bolt	**	4	33	Nut	▲	4
4	Spring Washer	**	4	34	Bolt	▲	4
5	Bolt	**	12	35	Spring Washer	▲	4
6	Washer	**	12	36	Side Roller Bracket	▲	4
7	Spring Washer	**	12	37	Bolt	▲	4
8	Nut	**	12	38	Washer	▲	4
	Caster Kit	MH2MPT202G		39	Bearing	▲	4
9	Caster Frame	▲	2	40	Chain:		
10	Bolt	▲	2		(2MPT2, 2MPT5)	MH2MPT208G	1
11	Nut	▲	2		(2MPT3, 2MPT6)	MH2MPT302G	1
12	Washer	▲	4		(2MPT4, 2MPT7)	MH2MPT403G	1
13	Wheel	▲	2		Chain Adjustment Kit	MH2MPT209G	
14	Bushing	▲	2	41	Chain Adjustment Bolt	▲	1
15	Roller Bearing	▲	2	42	Nut	▲	1
16	Bushing	▲	2	43	Nut	▲	1
17	Brake	MH2MPT203G	1	44	Bolt	**	2
	Wheel Kit	MH2MPT204G			Chain Roller Assembly Kit	MH2MPT210G	
18	Washer	▲	4	45	Bolt	▲	1
19	Wheel	▲	2	46	Nut	▲	1
20	Bushing	▲	2	47	Washer	▲	1
21	Roller Bearing	▲	2	48	Roller	▲	1
22	Bushing	▲	2	49	Bushing	▲	1
23	Bolt	▲	2	50	Roller Housing	▲	1
24	Nut	▲	2	51	Shaft	▲	1
	Roller Kit	MH2MPT205G		52	Complete Hydraulic Assembly:		
25	Nut	▲	4		(2MPT2, 2MPT5)	MH2MPT211G	1
26	Spring Washer	▲	4		(2MPT3, 2MPT6)	MH2MPT303G	1
27	Washer	▲	4		(2MPT4, 2MPT7)	MH2MPT403G	1
28	Washer	▲	4				
29	Axle	▲	4				
30	Bushing	▲	4				
31	Roller	▲	4				

(▲) Available as part of kit only.

(*) Not available as repair part.

(**) Common hardware, not offered as a replacement part.

For Repair Parts, call 1-800-323-0620

24 hours a day – 365 days a year

Please provide following information:

- Model number
- Serial number (if any)
- Part description and number as shown in parts list

E
N
G
L
I
S
H

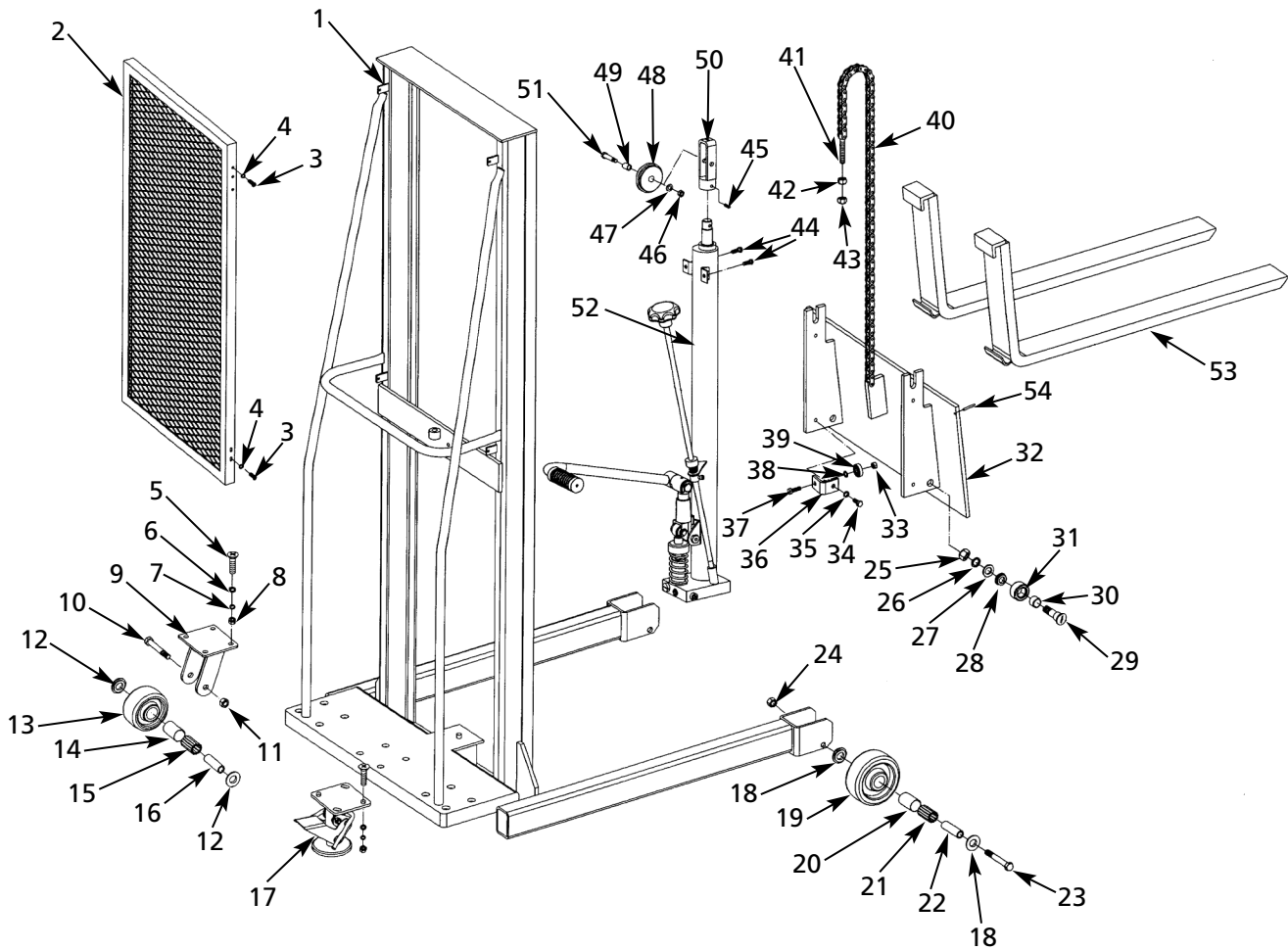

Figure 4 – Repair Parts Illustration for Fork Lift

Models 2MPT8, 2MPT9 and 2MPU1

Repair Parts List for Fork Lift

Ref. No.	Description	Part No.	Qty.	Ref. No.	Description	Part No.	Qty.
1	Mast	*	1	32	Fork Carriage	MH2MPT801G	1
2	Protective Grill: (2MPT8) (2MPT9) (2MPU1)	MH2MPT202G MH2MPT302G MH2MPT402G	1 1 1		Side Roller Kit	MH2MPT207G	
3	Bolt	**	4	33	Nut	▲	4
4	Spring Washer	**	4	34	Bolt	▲	4
5	Bolt	**	12	35	Spring Washer	▲	4
6	Washer	**	12	36	Side Roller Bracket	▲	4
7	Spring Washer	**	12	37	Bolt	▲	4
8	Nut	**	12	38	Washer	▲	4
	Caster Kit	MH2MPT202G		39	Bearing	▲	4
9	Caster Frame	▲	2	40	Chain:		
10	Bolt	▲	2		(2MPT8)	MH2MPT208G	1
11	Nut	▲	2		(2MPT9)	MH2MPT302G	1
12	Washer	▲	4		(2MPU1)	MH2MPT403G	1
13	Wheel	▲	2		Chain Adjustment Kit	MH2MPT209G	
14	Bushing	▲	2	41	Chain Adjustment Bolt	▲	1
15	Roller Bearing	▲	2	42	Nut	▲	1
16	Bushing	▲	2	43	Nut	▲	1
17	Brake	MH2MPT203G	1	44	Bolt	**	2
	Wheel Kit	MH2MPT204G			Chain Roller Assembly Kit	MH2MPT210G	
18	Washer	▲	4	45	Bolt	▲	1
19	Wheel	▲	2	46	Nut	▲	1
20	Bushing	▲	2	47	Washer	▲	1
21	Roller Bearing	▲	2	48	Roller	▲	1
22	Bushing	▲	2	49	Bushing	▲	1
23	Bolt	▲	2	50	Roller Housing	▲	1
24	Nut	▲	2	51	Shaft	▲	1
	Roller Kit	MH2MPT205G		52	Complete Hydraulic Assembly:		
25	Nut	▲	4		(2MPT8)	MH2MPT211G	1
26	Spring Washer	▲	4		(2MPT9)	MH2MPT303G	1
27	Washer	▲	4		(2MPU1)	MH2MPT403G	1
28	Washer	▲	4	53	Fork	MH2MPT802G	2
29	Axle	▲	4	54	Roll Pin	**	2
30	Bushing	▲	4				
31	Roller	▲	4				

(▲) Available as part of kit only.

(*) Not available as repair part.

(**) Common hardware, not offered as a replacement part.

For Repair Parts, call 1-800-323-0620

24 hours a day – 365 days a year

Please provide following information:

- Model number
- Serial number (if any)
- Part description and number as shown in parts list

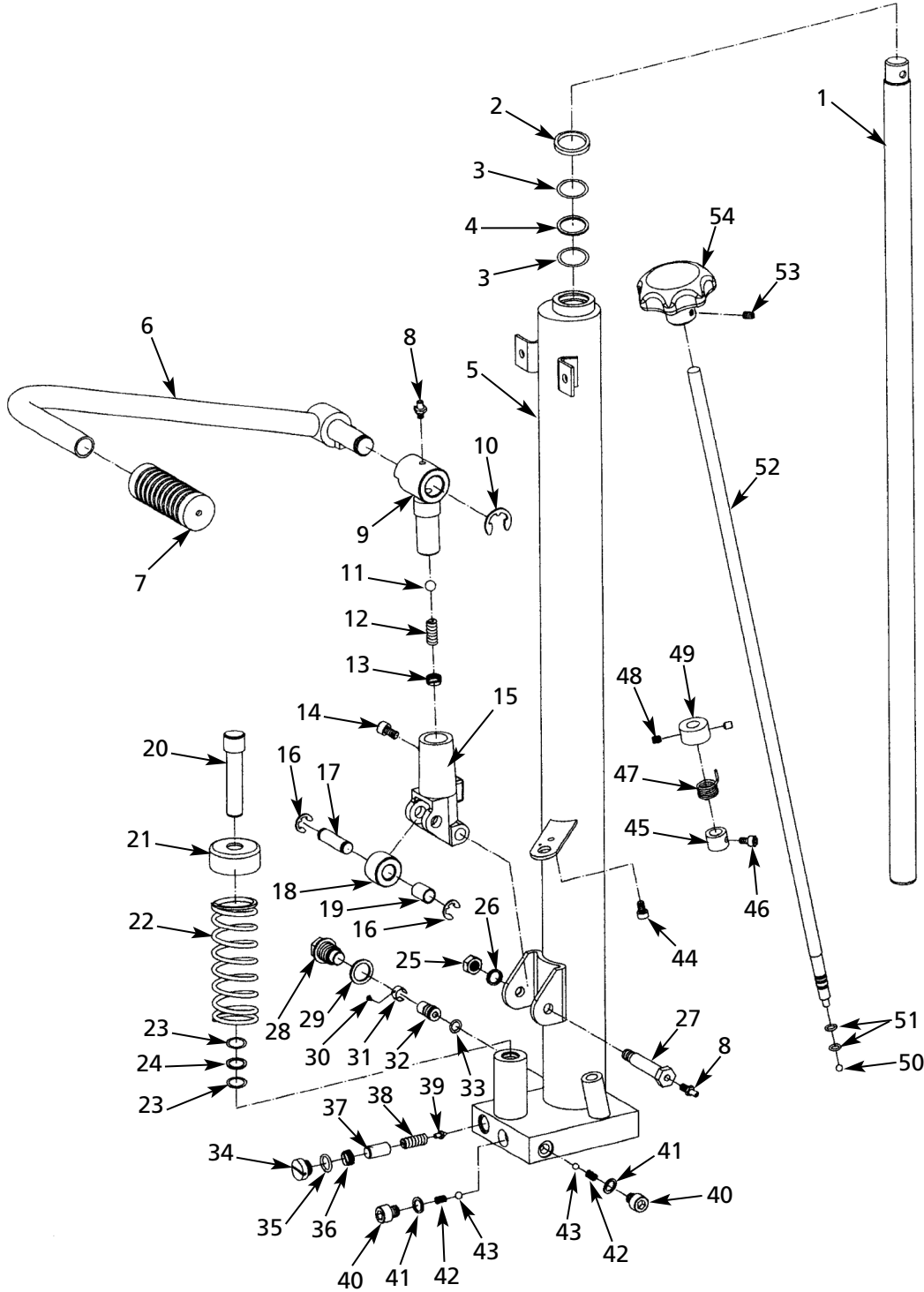

Figure 5 – Repair Parts Illustration for Pump Unit

ENGLISH

Models 2MPT2 thru 2MPT9, 2MPU1

Repair Parts List for Pump Unit

Ref. No.	Description	Part No.	Qty.	Ref. No.	Description	Part No.	Qty.
1	Piston Rod: (2MPT2, 2MPT5 and 2MPT8) (2MPT3, 2MPT6 and 2MPT9) (2MPT4, 2MPT7 and 2MPU1)	MH2MPT212G MH2MPT304G MH2MPT404G	1 1 1				
	Ring/Seal Kit	MH2MPT213G			Plug Kit #1	MH2MPT219G	
2	Dust Ring	▲	1	28	Screw	▲	1
3	O-Ring	▲	1	29	Seal Washer	▲	1
4	Ring	▲	1	30	Bolt	▲	1
5	Pump Body	*	1	31	Liquid Throttle Sheath	▲	1
	Pedal Bar Kit	MH2MPT214G		32	Valve Seat	▲	1
6	Pedal Bar	▲	2	33	O-Ring	▲	1
7	Rubber Cover	▲	1		Safety Valve Kit	MH2MPT220G	
	Pedal Seat Kit	MH2MPT215G		34	Screw	▲	1
8	Grease Cup	▲	1	35	Ring	▲	1
9	Pedal Bar Seat	▲	1	36	Adjusting Bolt	▲	1
10	Retaining Ring	▲	1	37	Pin	▲	1
11	Steel Ball	▲	1	38	Spring	▲	1
12	Spring	▲	1	39	Spindle	▲	1
13	Adjusting Bolt	▲	1		Plug Kit #2	MH2MPT221G	
14	Bolt	▲	1	40	Bolt	▲	2
	Pedal Bracket Kit	MH2MPT216G		41	Seal Washer	▲	1
15	Bracket	▲	1	42	Spring	▲	1
16	Retaining Ring	▲	1	43	Steel Ball	▲	1
17	Shaft	▲	1		Fix Ring/Spring Kit	MH2MPT222G	
18	Pressure Roller	▲	1	44	Bolt	▲	1
19	Bushing	▲	1	45	Fix Ring	▲	1
	Pump Piston Kit	MH2MPT217G		46	Bolt	▲	1
20	Pump Piston	▲	1	47	Spring	▲	1
21	Spring Cap	▲	1	48	Bolt	▲	2
22	Spring	▲	2	49	Valve Rod Fix Ring	▲	2
23	O-Ring	▲	1	50	Steel Ball	MH2MPT223G	2
24	Ring	▲	1		Valve Rod Kit	MH2MPT224G	
	Pivot Pin Assembly Kit	MH2MPT218G		51	O-Ring	▲	2
8	Grease Cup	▲	1	52	Valve Rod	▲	1
25	Nut	▲	1		Knob Assembly Kit	MH2MPT225G	
26	Spring Washer	▲	1	53	Bolt	▲	1
27	Bolt	▲	1	54	Knob	▲	1

(▲) Available as part of kit only.

(*) Not available as repair part.

Dayton® Fork and Platform Lifts

LIMITED WARRANTY

DAYTON ONE-YEAR LIMITED WARRANTY. DAYTON® FORK AND PLATFORM LIFTS, MODELS COVERED IN THIS MANUAL, ARE WARRANTED BY DAYTON ELECTRIC MFG. CO. (DAYTON) TO THE ORIGINAL USER AGAINST DEFECTS IN WORKMANSHIP OR MATERIALS UNDER NORMAL USE FOR ONE YEAR AFTER DATE OF PURCHASE. ANY PART WHICH IS DETERMINED TO BE DEFECTIVE IN MATERIAL OR WORKMANSHIP AND RETURNED TO AN AUTHORIZED SERVICE LOCATION, AS DAYTON DESIGNATES, SHIPPING COSTS PREPAID, WILL BE, AS THE EXCLUSIVE REMEDY, REPAIRED OR REPLACED AT DAYTON'S OPTION. FOR LIMITED WARRANTY CLAIM PROCEDURES, SEE "PROMPT DISPOSITION" BELOW. THIS LIMITED WARRANTY GIVES PURCHASERS SPECIFIC LEGAL RIGHTS WHICH VARY FROM JURISDICTION TO JURISDICTION.

LIMITATION OF LIABILITY. TO THE EXTENT ALLOWABLE UNDER APPLICABLE LAW, DAYTON'S LIABILITY FOR CONSEQUENTIAL AND INCIDENTAL DAMAGES IS EXPRESSLY DISCLAIMED. DAYTON'S LIABILITY IN ALL EVENTS IS LIMITED TO AND SHALL NOT EXCEED THE PURCHASE PRICE PAID.

WARRANTY DISCLAIMER. A DILIGENT EFFORT HAS BEEN MADE TO PROVIDE PRODUCT INFORMATION AND ILLUSTRATE THE PRODUCTS IN THIS LITERATURE ACCURATELY; HOWEVER, SUCH INFORMATION AND ILLUSTRATIONS ARE FOR THE SOLE PURPOSE OF IDENTIFICATION, AND DO NOT EXPRESS OR IMPLY A WARRANTY THAT THE PRODUCTS ARE MERCHANTABILITY, OR FIT FOR A PARTICULAR PURPOSE, OR THAT THE PRODUCTS WILL NECESSARILY CONFORM TO THE ILLUSTRATIONS OR DESCRIPTIONS. EXCEPT AS PROVIDED BELOW, NO WARRANTY OR AFFIRMATION OF FACT, EXPRESSED OR IMPLIED, OTHER THAN AS STATED IN THE "LIMITED WARRANTY" ABOVE IS MADE OR AUTHORIZED BY DAYTON.

Technical Advice and Recommendations, Disclaimer. Notwithstanding any past practice or dealings or trade custom, sales shall not include the furnishing of technical advice or assistance or system design. Dayton assumes no obligations or liability on account of any unauthorized recommendations, opinions or advice as to the choice, installation or use of products.

Product Suitability. Many jurisdictions have codes and regulations governing sales, construction, installation, and/or use of products for certain purposes, which may vary from those in neighboring areas. While attempts are made to assure that Dayton products comply with such codes, Dayton cannot guarantee compliance, and cannot be responsible for how the product is installed or used. Before purchase and use of a product, review the product applications, and all applicable national and local codes and regulations, and be sure that the product, installation, and use will comply with them.

Certain aspects of disclaimers are not applicable to consumer products; e.g., (a) some jurisdictions do not allow the exclusion or limitation of incidental or consequential damages, so the above limitation or exclusion may not apply to you; (b) also, some jurisdictions do not allow a limitation on how long an implied warranty lasts, consequently the above limitation may not apply to you; and (c) by law, during the period of this Limited Warranty, any implied warranties of implied merchantability or fitness for a particular purpose applicable to consumer products purchased by consumers, may not be excluded or otherwise disclaimed.

Prompt Disposition. A good faith effort will be made for prompt correction or other adjustment with respect to any product which proves to be defective within limited warranty. For any product believed to be defective within limited warranty, first write or call dealer from whom the product was purchased. Dealer will give additional directions. If unable to resolve satisfactorily, write to Dayton at address below, giving dealer's name, address, date, and number of dealer's invoice, and describing the nature of the defect. Title and risk of loss pass to buyer on delivery to common carrier. If product was damaged in transit to you, file claim with carrier.

Manufactured for Dayton Electric Mfg. Co., 5959 W. Howard St., Niles, Illinois 60714-4014 U.S.A.