

[®]
Dayton



Centrifugal Direct-Drive In-Line Duct Blowers

**Models 2RB86, 2RB87, 5TCK6 thru 5TCK9,
5TCL0 thru 5TCL2, 10C387, 10C388,
20UD15 thru 20UD17**

®
Dayton

**PLEASE READ AND SAVE
THESE INSTRUCTIONS.**

**READ CAREFULLY
BEFORE ATTEMPTING
TO ASSEMBLE, INSTALL,
OPERATE OR MAINTAIN THE
PRODUCT DESCRIBED.**

**PROTECT YOURSELF AND
OTHERS BY OBSERVING ALL
SAFETY INFORMATION. FAILURE
TO COMPLY WITH INSTRUCTIONS
COULD RESULT IN PERSONAL
INJURY AND/OR PROPERTY
DAMAGE! RETAIN INSTRUCTIONS
FOR FUTURE REFERENCE.**

**PLEASE REFER TO BACK COVER
FOR INFORMATION REGARDING
DAYTON'S WARRANTY AND OTHER
IMPORTANT INFORMATION.**

Model #: _____

Serial #: _____

Purch. Date: _____

*Form 5S6963 / Printed in USA
04632 Version 1 06/2014*

**© 2006 - 2014 Dayton Electric Manufacturing Co.
All Rights Reserved**

BEFORE YOU BEGIN

▲ WARNING *Installation, troubleshooting and parts replacement are to be performed only by qualified personnel.*



Electrical Requirements:

- The motor voltage and ampere rating must be checked for compatibility with the electrical supply prior to final electrical connection. Supply wiring to the fan must be properly fused, and conform to local and national electrical codes.



Tools Needed:

- Drill
- Multimeter
- Lock-Out Tag-Out
- Hex Keys/Wrench

UNPACKING



Contents:

- Dayton® Utility Exhaust Belt-Drive Blower (1)
- Operating Instructions and Parts Manual (1)



Inspect:

- After unpacking unit, inspect carefully for any damage that may have occurred during transit. Check for loose, missing, or damaged parts. Shipping damage claim must be filed with carrier.
- Check all bolts, screws, set-screws, etc. for looseness that may have occurred during transit. Retighten as required. Rotate blower wheel by hand to be sure it turns freely.
- **See General Safety Instructions on page 2, and Cautions and Warnings as shown.**



GENERAL SAFETY INSTRUCTIONS

Centrifugal in-line duct blowers feature a unique combination of installation flexibility, rugged construction, ease of service, high efficiency and low sound levels. Blowers are the ideal selection for indoor clean air applications (including intake, exhaust, return or make-up air systems) where space is a prime consideration. The square housing design, compact size and straight through airflow also give the system designer the flexibility to mount the unit horizontal or vertical. Each unit has two removable access panels for easy serviceability and is speed controllable.

⚠ DANGER *Do not depend on any switch as the sole means of disconnecting power when installing or servicing the ventilator. Always disconnect, lock and tag power source before installing or servicing. Failure to disconnect power source can result in fire, shock or serious injury. Motor will restart without warning after thermal protector trips. Do not touch operating motor, it may be hot enough to cause injury.*

⚠ DANGER *Do not place any body parts or objects in ventilator while motor is connected to power source.*

⚠ WARNING *Do not use this equipment in explosive atmospheres!*

1. Read and follow all instructions and cautionary markings. Make sure electrical power source conforms to requirements of equipment and local codes.
2. Blowers should be assembled, installed and serviced by a qualified technician. Have all electrical work performed by a qualified electrician.
3. Follow all local electrical and safety codes in the United States and Canada, as well as the National Electrical Code (NEC), the Occupational Safety and Health Act (OSHA), and the National Fire Protection Association (NFPA) Bulletin 96 in the United States. Ground motor in accordance with NEC Article 250 (grounding). Follow the Canadian Electric Code (CEC) in Canada.

⚠ CAUTION *To reduce the risk of injury to persons, observe the following:*

OSHA requires OSHA complying guards when blower is installed within 2.1 meters (7 feet) of floor or working level.

UL/cUL Standards require OSHA complying guards when blower is installed within 2.5 meters (8 feet) of floor or working level.

4. Motor must be securely and adequately grounded. Accomplish this by wiring with a grounded, metal-clad race way system by using a separate ground wire connected to the bare metal of the motor frame, or other suitable means.
5. Do not kink power cable or allow it to come in contact with sharp objects, oil, grease, hot surfaces or chemicals. Replace damaged cords immediately.
6. Never open access door to a duct with the ventilator running.

SPECIFICATIONS

	2RB87 5TCL0 5TCL1 5TCL2	5TCK9	2RB86 5TCK6 5TCK7 5TCK8 10C387 10C388	20UD15 20UD16 20UD17
Speeds	1	1	3	Variable
Recommended Speed Control	48C172	48C173	48C172	43Y140
Max. Inlet Temp.				104°F
Mounting Location	Indoor			
Mounting Position	Vertical/Horizontal			
Recommended NEMA 1 Disconnect Switch	1H400 (2 pole, 115/230V, 2 HP max)			
Agency Compliance	UL/cUL 705, AMCA Sound & Air			

Dimensions (inches)

	5TCK6 5TCK7	2RB86 5TCK8 10C387 10C388 20UD15	2RB87	5TCK9 5TCL0 20UD16	5TCL1 20UD17	5TCL2
A	12	15	17	19	23	26
B	13	16	21	21	22	26
C	8-7/8	11-7/8	13-7/8	15-7/8	19-7/8	22-7/8
D	1	1	1	1	1	1
Wheel Dia.	8-1/4	11	11	13-1/8	14-1/2	16-3/4
Shaft Dia.	5-16	1/2	1/2	1/2	5/8	5/8
Inlet Dia.	5-5/8	8-3/8	8-1/4	9-1/8	10-1/2	11-5/8

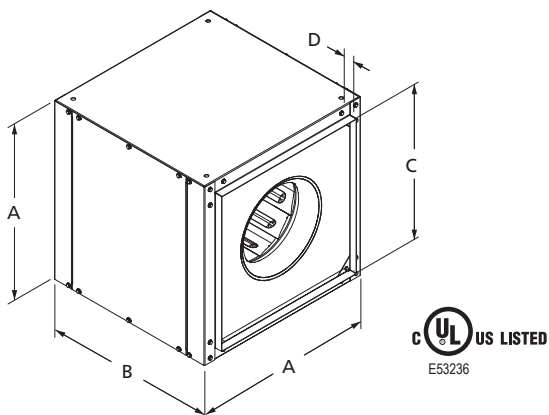

Figure 1

PERFORMANCE

Model 115V, 1-Phase HP	Model – ECM 115V, 1-Phase HP	RPM	Max BHP	Sones @ .125" SP @ 5 Ft.
5TCK6	1/30	—	—	1050 0.01 1.9
		—	—	1300 0.02 2.9
		—	—	1550 0.03 4.0
5TCK7	1/30	—	—	1050 0.01 2.9
		—	—	1300 0.02 3.7
		—	—	1550 0.04 5.5
10C387	1/12	—	—	1050 0.02 3.6
		—	—	1300 0.03 5.4
		—	—	1550 0.06 7.3
5TCK8	1/12	—	—	1050 0.02 3.9
		—	—	1300 0.03 5.3
		—	—	1550 0.06 7.4
10C388	1/12	—	—	1050 0.02 3.9
		—	—	1300 0.04 5.4
		—	—	1550 0.07 7.5
—	—	900	0.02	2.8
2RB86	1/8	20UD15	1/6	1050 0.03 4.5
				1300 0.06 6.7
				1550 0.10 9.3
—	—	1725	0.14	11.4
2RB87	1/4	—	—	1725 0.25 12.4
—	—	20UD16	1/2	900 0.07 4.6
—	—			1050 0.11 6.1
5TCL0	1/6			1140 0.14 7.2
—	—	1300	0.21	8.7
—	—	1550	0.35	11.5
5TCK9†	1/2	—	—	1725 0.48 14.1
—	—	20UD17	3/4	860 0.13 6.2
5TCL1	1/3			1140 0.30 10.5
—	—			1550 0.75 16.5
5TCL2	1/2	—	—	1140 0.56 13.4



Dayton Electric Mfg. Co. certifies that the blowers shown herein are licensed to bear the AMCA seal. The ratings shown are based on tests and procedures performed in accordance with AMCA Publication 211 and AMCA Publication 311 and comply with the requirements of the AMCA Certified Ratings Program.

CFM Air Delivery @ Static Pressure Shown								
0.00"	0.125"	0.25"	0.375"	0.50"	0.625"	0.75"	1.00"	1.25"
154	79	—	—	—	—	—	—	—
191	137	52	—	—	—	—	—	—
228	184	128	46	—	—	—	—	—
241	146	—	—	—	—	—	—	—
298	224	133	—	—	—	—	—	—
356	294	229	137	—	—	—	—	—
306	225	104	—	—	—	—	—	—
387	312	244	140	—	—	—	—	—
451	394	342	280	201	—	—	—	—
357	272	142	—	—	—	—	—	—
442	377	298	185	—	—	—	—	—
528	474	413	343	254	—	—	—	—
500	369	188	—	—	—	—	—	—
619	519	397	245	—	—	—	—	—
738	654	564	457	334	—	—	—	—
534	353	—	—	—	—	—	—	—
623	475	275	—	—	—	—	—	—
771	660	523	352	—	—	—	—	—
920	830	720	604	462	276	—	—	—
1024	948	850	751	641	507	352	—	—
1455	1403	1350	1292	1227	1156	1078	831	—
1016	894	766	587	—	—	—	—	—
1186	1080	976	858	707	—	—	—	—
1287	1189	1094	992	873	692	—	—	—
1468	1383	1298	1214	1122	1018	893	—	—
1750	1679	1607	1536	1466	1393	1313	1122	—
1948	1883	1818	1754	1692	1628	1562	1416	1239
1637	1487	1317	1033	—	—	—	—	—
2170	2061	1942	1818	1666	1446	1121	—	—
2950	2870	2790	2703	2614	2524	2429	2188	1809
3322	3194	3061	2922	2773	2587	2388	1808	—

Performance certified is for installation type B: Free inlet, Ducted outlet. Performance ratings do not include the effects of appurtenances (accessories). The sound ratings shown are loudness values in fan sones at 1.5 m (5 feet) in a hemispherical free field calculated per AMCA Standard 301. Values shown are for installation type B: free inlet hemispherical fan sone levels.

† 115/230V

INSTALLATION INSTRUCTIONS

▲ WARNING *Installation, troubleshooting and parts replacement are to be performed only by qualified personnel.*

1. Rotate the wheel by hand to ensure that it does not rub and rotates freely. Movement may occur during shipment, and realignment may be necessary. Refer to Figure 2 and chart for proper overlap or gap dimensions.
 - a. Centering can be accomplished by loosening the inlet cone bolts to move the inlet cone or by loosening the bearings in order to move the shaft.
 - b. Wheel and inlet cone overlap can be adjusted by loosening the wheel hub set screws and moving the wheel to the desired position. Tighten all fasteners and set screws securely.

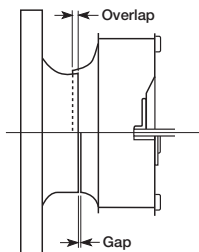

Figure 2

	2RB86		2RB87
	5TCK6		5TCK9
	5TCK7		5TCL0
	5TCK8		5TCL1
	10C388		5TCL2
	10C389		20DU16
	20DU15		20DU17
Overlap (inches)	–		1/4
Gap (inches)	1/8		–

2. Move the blower to the desired location and determine position of access panels.

NOTE: Blowers can be mounted horizontally, vertically or at an angle. Knockout holes are provided for ease of installation on the unit top and bottom panels. Refer to vibration isolator manufacturer's installation instructions.

IMPORTANT: The venturi end is the inlet side of the unit. Position the unit to the desired airflow direction.

IMPORTANT: The inlet and outlet duct length should be approximately 2-1/2 wheel diameters long before and after the blower to achieve cataloged performance.

3. After placing unit properly, connect it to the duct work. Duct on inlet and discharge should be the same height and width as inside dimensions of the square housing frame.
4. Use appropriate size fasteners to secure and tighten.

Electrical Connection

NOTE: When connecting electrical power, be certain not to restrict service to the motor or access panels.

1. Refer to Figure 3 and motor nameplate for wiring procedures. Motor and blower must be securely grounded (bare metal) to a suitable electric ground, such as a grounded water pipe or ground wire system.
2. Refer to switch manufacturer for installation and wiring procedures.

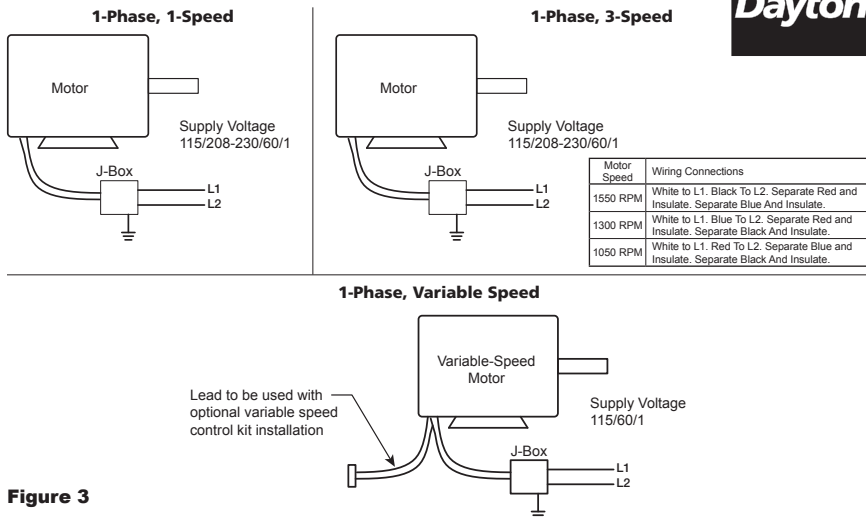
Figure 3

OPERATION

1. Before starting up or operating blower, check all fasteners for tightness. In particular, check set screws in wheel hub.
2. While in the OFF position, turn the blower wheel by hand to be sure it is not striking the orifice or any obstacle.
3. Start the blower and shut it off immediately to check rotation of the wheel with directional arrow in the motor compartment. Blower wheel should rotate CCW when viewing into the inlet side of the unit. See Figure 4.

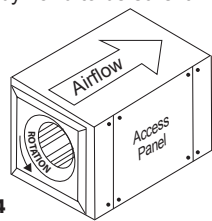
Figure 4

IMPORTANT: Correct direction of the wheel rotation is critical. Reversed rotation will result in poor air performance, motor overloading and possible burnout.

4. When the blower is started, observe the operation and check for any unusual noises.
5. With the system in full operation and all duct work attached, measure current (amps) input to the motor and compare with the nameplate rating (full-load amps) to determine if the motor is operating under safe load conditions.
6. Keep inlets and approaches to fan clean and free from obstruction.
7. Variable-speed electronically commutated motors (ECM) can be controlled two ways.
 - a. A motor mounted potentiometer is mounted on the case of the motor to adjust the speed manually. Turn the potentiometer using a screwdriver to adjust the speed.
 - b. The motor includes a capped motor lead that can be connected to a Dayton variable speed control kit 43Y140. The motor lead cap can be removed and connected to the nine-pin motor/transformer harness lead. Follow installation instructions provided with optional speed control kit.

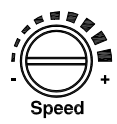
Figure 5

Inspection

Inspection of the fan should be conducted at the first 30 minute and 24 hour intervals of satisfactory operation.

1. 30 Minute Interval – Inspect bolts, set screws and motor mounting bolts. Adjust and tighten as necessary.
2. 24 Hour Interval – Check all internal components.

TROUBLESHOOTING GUIDE

Symptom	Possible Cause(s)	Corrective Action
Reduced airflow	1. System resistance too high	1. Check system: operation of dampers, obstruction in duct work, clean filters
	2. Unit running backwards	2. Correct as shown in Figure 4
	3. Excessive dirt buildup on wheel	3. Clean wheel
	4. Improper wheel alignment	4. Center wheel on inlet, Figure 2
Excessive noise or vibration	1. Wheel improperly aligned and rubbing	1. Center wheel on inlet, Figure 2
	2. Foreign objects in wheel or housing	2. Remove, check for damage or unbalance
	3. Wheel unbalance	3. Clean wheel, rebalance

MAINTENANCE

⚠ WARNING *Installation, troubleshooting and parts replacement are to be performed only by qualified personnel.*

⚠ WARNING *Disconnect and lockout power source before servicing.*

⚠ WARNING *The unit should be made non-functional when cleaning and/or maintaining.*

1. Keep inlets and approaches to blower clean and free from obstruction.
2. Depending on the usage a regularly scheduled inspection for cleaning the blower wheel, housing and surrounding areas should be established.
3. Generally clean and lubricate (where applicable) motor. Cleaning should be limited to exterior surfaces only. Removing dust buildup on motor cover ensures proper motor cooling.
4. Clean wheel occasionally to remove oil and dust buildup, this will ensure smooth and safe operation.

IMPORTANT: Uneven cleaning of the wheel will produce an out of balance condition that will cause vibration in the fan.

5. All fasteners should be checked for tightness each time maintenance checks are performed prior to restarting unit.

REPAIR PARTS ILLUSTRATION FOR CENTRIFUGAL DIRECT-DRIVE IN-LINE DUCT BLOWERS

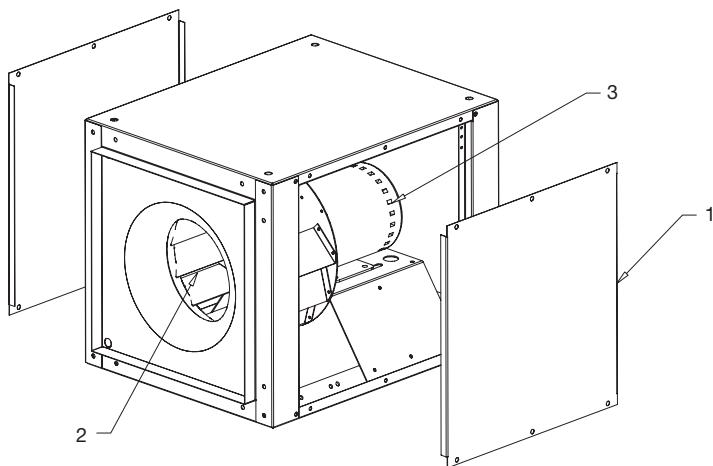

Ref. No.	Description	Part Number for Models:				Quantity.
		2RB86	2RB87	5TCK6	5TCK7	
1	Access Panel	21DW83	21DP55	21DW81	21DW81	1
2	Wheel	21DP54	21DP56	21DW97	21DW98	1
3	Motor	1AGF9	4YU27	4YU32	4YU32	1

Ref. No.	Description	Part Number for Models:				Quantity.
		5TCK8	5TCK9	5TCL0	5TCL1	
1	Access Panel	21DW83	21DW80	21DW80	21DW79	1
2	Wheel	21DW99	21DW91	21DW91	21DW93	1
3	Motor	1AGF9	4YU28	4YU23	4YU24	1

Ref. No.	Description	Part Number for Models:				Quantity.
		5TCL2	10C387	10C388	20UD15	
1	Access Panel	21DW78	21DW83	21DW83	21DW83	1
2	Wheel	21DW92	21DV81	21DV82	21DP54	1
3	Motor	21DW50	21DV81	21DV82	43Y135	1

Ref. No.	Description	Part Number for Models:		Quantity.
		20UD16	20UD17	
1	Access Panel	21DW80	21DW79	1
2	Wheel	21DW91	21DW93	1
3	Motor	43Y137	43Y138	1

For Repair Parts, call 1-800-Grainger
24 hours a day – 365 days a year

Please provide following information:

- Model number
- Serial number (if any)
- Part description and number as shown in parts list

DAYTON ONE-YEAR LIMITED WARRANTY

DAYTON ONE-YEAR LIMITED WARRANTY. All Dayton® product models covered in this manual are warranted by Dayton Electric Mfg. Co. ("Dayton") to the original user against defects in workmanship or materials under normal use for one year after date of purchase. If the Dayton product is part of a set, only the portion that is defective is subject to this warranty. Any product or part which is determined to be defective in material or workmanship and returned to an authorized service location, as Dayton or Dayton's designee designates, shipping costs prepaid, will be, as the exclusive remedy, repaired or replaced with a new or reconditioned product or part of equal utility or a full refund given, at Dayton's or Dayton's designee's option, at no charge. For limited warranty claim procedures, see "Warranty Service" below. This warranty is void if there is evidence of misuse, mis-repair, mis-installation, abuse or alteration. This warranty does not cover normal wear and tear of Dayton products or portions of them, or products or portions of them which are consumable in normal use. This limited warranty gives purchasers specific legal rights, and you may also have other rights which vary from jurisdiction to jurisdiction.

WARRANTY DISCLAIMERS AND LIMITATIONS OF LIABILITY RELATING TO ALL CUSTOMERS FOR ALL PRODUCTS

LIMITATION OF LIABILITY. TO THE EXTENT ALLOWABLE UNDER APPLICABLE LAW, DAYTON'S LIABILITY FOR CONSEQUENTIAL AND INCIDENTAL DAMAGES IS EXPRESSLY DISCLAIMED. DAYTON'S LIABILITY IN ALL EVENTS IS LIMITED TO AND SHALL NOT EXCEED THE PURCHASE PRICE PAID.

WARRANTY DISCLAIMER. A DILIGENT EFFORT HAS BEEN MADE TO PROVIDE PRODUCT INFORMATION AND ILLUSTRATE THE PRODUCTS IN THIS LITERATURE ACCURATELY; HOWEVER, SUCH INFORMATION AND ILLUSTRATIONS ARE FOR THE SOLE PURPOSE OF IDENTIFICATION, AND DO NOT EXPRESS OR IMPLY A WARRANTY THAT THE PRODUCTS ARE MERCHANTABILITY, OR FIT FOR A PARTICULAR PURPOSE, OR THAT THE PRODUCTS WILL NECESSARILY CONFORM TO THE ILLUSTRATIONS OR DESCRIPTIONS. EXCEPT AS PROVIDED BELOW, NO WARRANTY OR AFFIRMATION OF FACT, EXPRESSED OR IMPLIED, OTHER THAN AS STATED IN THE "LIMITED WARRANTY" ABOVE IS MADE OR AUTHORIZED BY DAYTON.

PRODUCT SUITABILITY. MANY JURISDICTIONS HAVE CODES AND REGULATIONS GOVERNING SALES, CONSTRUCTION, INSTALLATION, AND/OR USE OF PRODUCTS FOR CERTAIN PURPOSES, WHICH MAY VARY FROM THOSE IN NEIGHBORING AREAS. WHILE ATTEMPTS ARE MADE TO ASSURE THAT DAYTON PRODUCTS COMPLY WITH SUCH CODES, DAYTON CANNOT GUARANTEE COMPLIANCE, AND CANNOT BE RESPONSIBLE FOR HOW THE PRODUCT IS INSTALLED OR USED. BEFORE PURCHASE AND USE OF A PRODUCT, REVIEW THE SAFETY/SPECIFICATIONS, AND ALL APPLICABLE NATIONAL AND LOCAL CODES AND REGULATIONS, AND BE SURE THAT THE PRODUCT, INSTALLATION, AND USE WILL COMPLY WITH THEM.

CONSUMERS ONLY. CERTAIN ASPECTS OF DISCLAIMERS ARE NOT APPLICABLE TO CONSUMER PRODUCTS SOLD TO CONSUMERS; (A) SOME JURISDICTIONS DO NOT ALLOW THE EXCLUSION OR LIMITATION OF INCIDENTAL OR CONSEQUENTIAL DAMAGES, SO THE ABOVE LIMITATION OR EXCLUSION MAY NOT APPLY TO YOU; (B) ALSO, SOME JURISDICTIONS DO NOT ALLOW A LIMITATION ON HOW LONG AN IMPLIED WARRANTY LASTS, SO THE ABOVE LIMITATION MAY NOT APPLY TO YOU; AND (C) BY LAW, DURING THE PERIOD OF THIS LIMITED WARRANTY, ANY IMPLIED WARRANTIES OF MERCHANTABILITY OR FITNESS FOR A PARTICULAR PURPOSE APPLICABLE TO CONSUMER PRODUCTS PURCHASED BY CONSUMERS, MAY NOT BE EXCLUDED OR OTHERWISE DISCLAIMED.

THIS LIMITED WARRANTY ONLY APPLIES TO UNITED STATES PURCHASERS FOR DELIVERY IN THE UNITED STATES.

WARRANTY SERVICE

To obtain warranty service if you purchased the covered product directly from W.W. Grainger, Inc. ("Grainger"), (i) write or call or visit the local Grainger branch from which the product was purchased or another Grainger branch near you (see www.grainger.com for a listing of Grainger branches); or (ii) contact Grainger by going to www.grainger.com and clicking on the "Contact Us" link at the top of the page, then clicking on the "Email us" link; or (iii) call Customer Care (toll free) at 1-888-361-8649. To obtain warranty service if you purchased the covered product from another distributor or retailer, (i) go to www.grainger.com for Warranty Service; (ii) write or call or visit a Grainger branch near you; or (iii) call Customer Care (toll free) at 1-888-361-8649. In any case, you will need to provide, to the extent available, the purchase date, the original invoice number, the stock number, a description of the defect, and anything else specified in this Dayton One-Year Limited Warranty. You may be required to send the product in for inspection at your cost. You can follow up on the progress of inspections and corrections in the same ways. Title and risk of loss pass to buyer on delivery to common carrier, so if product was damaged in transit to you, file claim with carrier, not retailer, Grainger or Dayton. For warranty information for purchasers and/or delivery outside the United States, please use the following applicable contact information:

**Dayton Electric Mfg. Co.,
100 Grainger Parkway, Lake Forest, IL 60045 U.S.A.
or call +1-888-361-8649**