

# Dayton Sewage Pumps



## PUMPS technical data sheet

Submersible Sewage pumps are designed to remove sewage wastewater from a residential home or commercial office. These pumps are designed to pass the typical suspended solids associated with sewage wastewater. Sewage pumps typically operate intermittently and automatically with a float switch and can accommodate solids up to 2" in diameter.



### 4LB99 1 HP, Cast Iron Submersible Sewage Pump

<b>HP</b>	1
<b>Voltage</b>	200-240V
<b>Phase</b>	Single
<b>Frequency</b>	60 Hz
<b>Run Amps</b>	8.8/8.3A
<b>Start Amps</b>	21.5/25.8A
<b>RPM</b>	1750
<b>Motor Type</b>	PSC Oil-filled with Class B insulation

<b>Overload Protection</b>	Internal Thermal Overload
<b>Motor Shaft Material</b>	Stainless Steel
<b>Motor Housing Material</b>	Cast Iron
<b>Motor Duty</b>	Continuous
<b>Motor End Bearing</b>	Single Row Ball
<b>Pump End Bearing</b>	Single Row Ball
<b>Lubrication</b>	Oil Lubricated
<b>Discharge</b>	2 Inch Flanged, Vertical
<b>Volute Material</b>	Cast Iron
<b>Base Material</b>	Cast Iron
<b>Impeller Type</b>	Open Vortex
<b>Impeller Material</b>	Cast Iron
<b>Hardware Material</b>	Stainless Steel
<b>O-rings</b>	Buna-N
<b>Seal Type</b>	Single Mechanical
<b>Seal Materials</b>	Silicon Carbide/Silicon Carbide/Buna N
<b>Operation</b>	Automatic / Vertical Switch
<b>Power Cord</b>	14/3 SOW, 20' (6.1m), NEMA 6-15P 240V Plug
<b>Max. Solids Handling</b>	2" (51mm) spherical
<b>Max. Water Temperature</b>	104°F (40°C)
<b>Designed Fluid Environment</b>	Water / Sewage Wastewater
<b>Switch Type</b>	Vertical
<b>Switch Cord</b>	20' (6.1m) SJOW Power Cord
<b>Switch Plug</b>	NEMA 6-15P Piggyback Plug
<b>Switch Max. Run Amps</b>	12A
<b>Switch Max. Start Amps</b>	60A
<b>Switch Pumping Range</b>	On at 13.4" (340mm) Off at 7.41" (188mm)

### Outline Dimensions

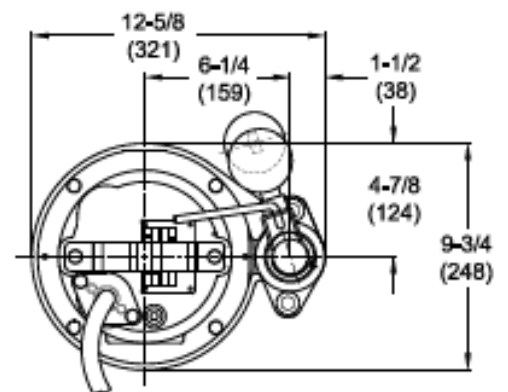
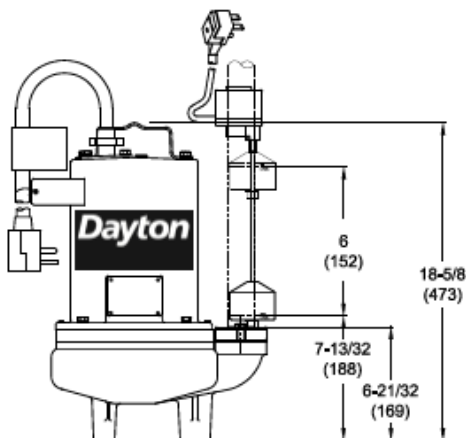

## Performance Data

Head	Feet	10	15	20	25	30	35	36.5
	Meters	3.1	4.6	6.1	7.6	9.1	10.7	11.1
Flow Rate	GPM	195	165	130	95	48	10	0
	LPM	738	625	492	360	182	38	0

## Performance Chart

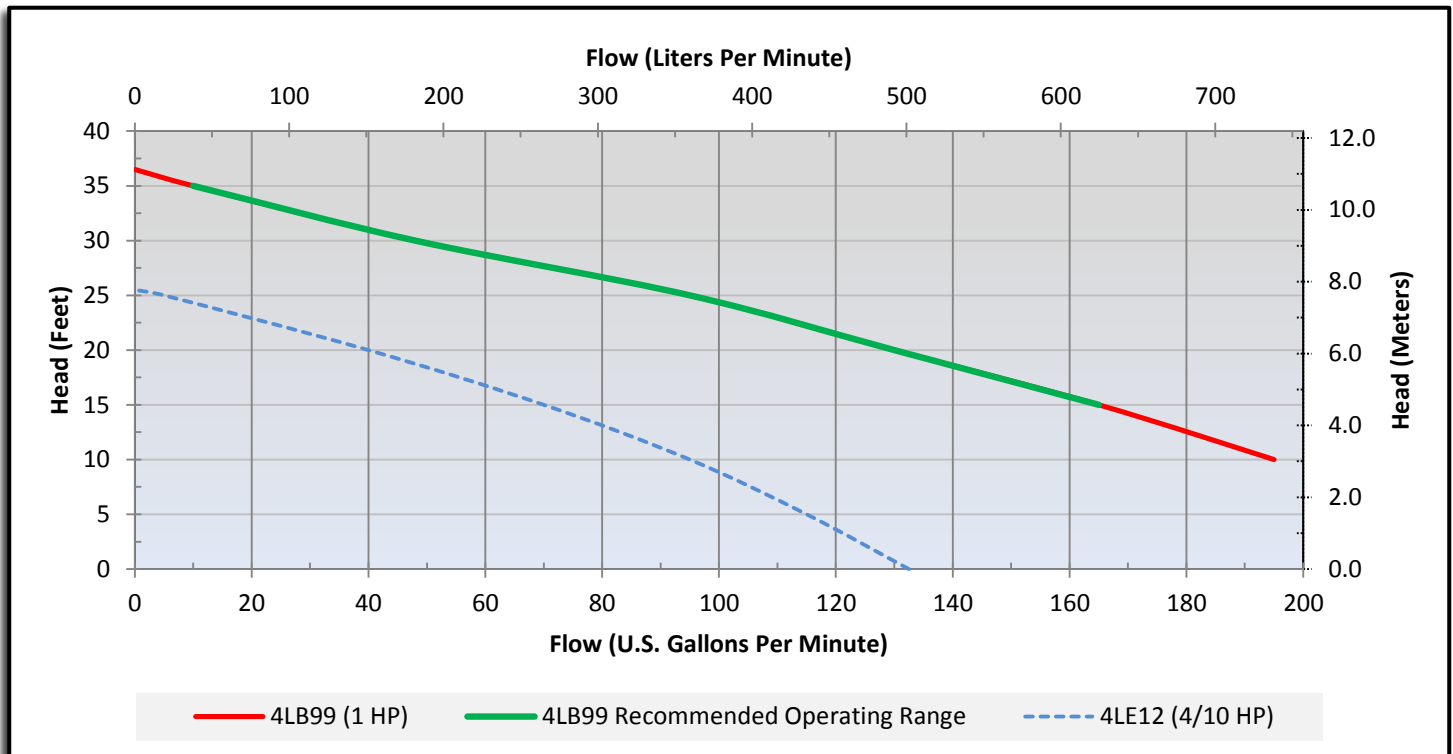

**WARNING:** Use only with nonflammable liquids compatible with pump component materials and in nonflammable/nonexplosive atmospheres.

Call or visit your local branch or go to [grainger.com/dayton](http://grainger.com/dayton) for complete product line information



Find it at Grainger.

© 2013 W.W. Grainger, Inc.