

Dayton® Electric Vibrator Motor 3 phase 2 pole 3600 rpm

GENERIC fact sheet
Item # 1DYL3

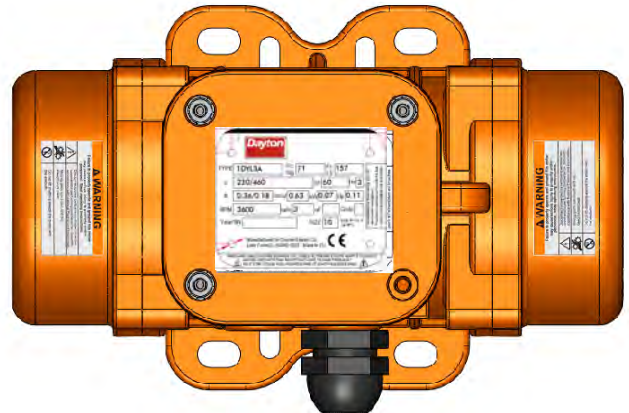

PRODUCT - FEATURES

Dayton® External Electric Vibrator Motors afford long term durability with a 2-year-warranty including electrical components, reflecting the care taken over selection of components (oversized SKF bearings) and the high level of precision in manufacturing.



PRODUCT - FUNCTION

Dayton® External Electric Vibrator Motors are used in a number of different applications: as material flow aids, for screening, conveying, cleaning, detaching, compacting, and sorting.



PRODUCT - MAIN BENEFITS

- Motor protection IP 65 - NEMA 4
- Continuous Duty S1
- Insulation Class F
- Adjustable mass
- Standard Voltage 230/460 V, 60 Hz 3 Phase 3600 RPM



Dayton® Electric Vibrator Motor 3 phase 2 pole 3600 rpm

GENERIC fact sheet
Item # 1DYL3

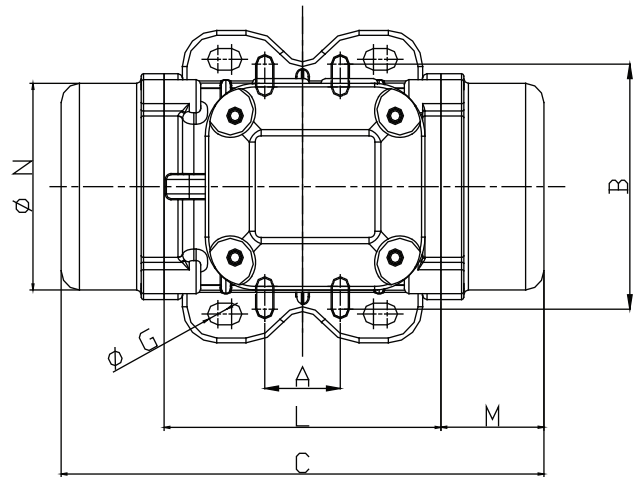
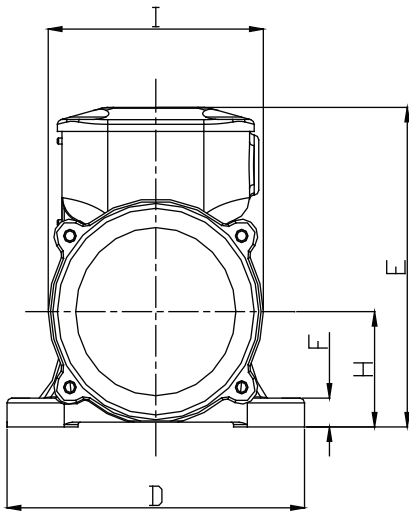

OVERALL DIMENSIONS

A	B	C	D	
inch	inch	inch	inch	
2,44-2,91	4.17	8.31	5.12	
1.3	3,27-4,02			
E	F	ØG (HOLES)		H
inch	inch	inch	N°	inch
5.35	0.47	0.35	4	1.89
		0.28		
I	L	M	N	
inch	inch	inch	inch	
3.70	4.76	1.77	3.39	

Weight	Unbalance	Centrifugal Force	Bearing Life (hrs)
Position	in.-lb	lb	w/1.3 Load Factor
100%	0.36	157	26,123
80%	0.28	125	51,022
50%	0.18	78	>100000