

**Corbin
Russwin** 
ASSA ABLOY

DC6000 Series

Door Closers



ASSA ABLOY, the global leader
in door opening solutions



Introduction

DC6000

Applications

Corbin Russwin's history combines high-quality product and innovative design. That tradition continues with the Grade 1 DC6000 Series door closer, designed and engineered with quality features such as captured valves and a complete range of arms. The DC6000 series is the perfect closer for high-use openings or openings that must meet ADA requirements, such as schools, office buildings, health care facilities, and retail complexes. The series also meets UL and UL10C positive pressure requirements for fire door openings.

Quality

More than meets the eye...The design of the DC6000 Series incorporates internal advantages engineered to provide consistent quality operation. Double O-rings, a robust spring tube design and captured valves ensure longevity.

Security

Engineered to meet high security standards, the DC6000 offers a full array of security features. Heavy-duty arms offer increased strength for high-use, high-abuse situations. Captured valves and optional Torx® security screws also assist in security situations by making the closer tamper resistant.

Key Advantages

- Heavy-duty forged arm
- Spring-adjust
- Captured valves
- Self-drilling screws
- Quik-Install™ bracket
- Cast iron body
- Retrofit plates
- Powder painted arms

Table of Contents

Introductions	2
Features.....	3 -5
Mountings	6-7
Arms Options.....	8-10
Mounting Brackets.....	11
Brackets and Covers.....	12-13
Size and Handing.....	14-15
Helpful Terms	16
How to Order	17
Quick Codes	18-19
Specifications.....	20-21

Versatility

Conditions vary from job to job, but a top-quality product that is dependable, easy to install and versatile is a must. The DC6000 Series door closer is the solution. A variety of features makes this the choice for retrofitting, quick installation, and longevity. Corbin Russwin offers a wide variety of arms, tracks and special brackets to meet special header/ frame conditions. The small footprint and unobtrusive cover are additional advantages to a versatile line of closers.

Features	Benefits
Closer Arms	Forged steel main arm for strength and durability
	Full complement to meet most installation demands
Powder Painted Arms	Environmentally safe process
	Greater corrosion resistance
Cover Options	Plastic covers - painted finishes Metal covers - painted or plated finishes
Cast Iron Body	Strong and durable; withstands expected abusive conditions
Captured Valves	Reduces possibility of valve removal
Spring Adjust	Easier to adjust for optimum power setting
Springs	Chrome silicon wire, triple set for longer life
Closer Fluid	Extended temperature oil with friction-reduction additives
Self-Drilling Screws	Easier, quicker installation
Quik-Install™ Bracket	Easier installation of closer body

Features

DC6000

DC6200 - Multi-Sized DC6400 - Sizes 1-6, half size adjustable

Features

Spring Power

DC6200 closers: multi-sized; fully adjustable sizes 1 through 6.
DC6400 closers: sizes 1 through 6; half-size adjustability.
For recommended sizes, see page 14.

Handing

Non-handed (with the exception of some arms and accessories).

Body

Cast-iron case with seamless cold headed steel spring tube.

Arm

Standard: forged steel.
Arm options pages 8-10.

Spindle

Heat-treated steel with a crowned gear set for increased efficiency.

Piston

1-3/8" diameter; precision machined, heat-treated steel.

Springs

Chrome silicon wire.

Valves

Latching speed valve standard.

Closing speed valve standard.

Multiple backcheck location valve and backcheck intensity valve standard.

Delayed action valve optional. Delayed action preset for 20 seconds. Between 90° and 70° for all mountings. To order specify M71.

Seals

"O" rings.

Fluid

Standard: high lubricity extreme temperature hydraulic fluid.

Degree of Opening

Up to full 180° opening standard for regular, top jamb and parallel arm mountings, conditions permitting.

Power Adjustment Arm Bracket

15% adjustment standard.

Cover

Standard: plastic V-O flame rated cover.
Optional: full metal cover; specify M73 x hand.

Mountings

Standard: regular or top jamb.
Parallel arm or tri-style packaging: specify DC6210 or DC6410.
Optional mountings available; see Mountings, page 6.

Mounting Bracket

Quik-Install™ mounting bracket standard.

Fasteners

Standard: self-drilling screws.
Optional: sex nuts and bolts (SNBs); specify M54.

Corrosion Protection

Painted protective coating on all metal surfaces for use in corrosive environments.

Security Package

Includes heavy-duty parallel or regular arm, full metal cover and security Torx® machine screws. Specify M87 x arm x hand. See pages 8-12 for arm options.

Warranty

Ten-year limited warranty. Refer to Corbin Russwin price book for details.

Finishes

Standard painted finishes

Old Designation	Description	Specify
USP	Primed	600
SBL	Silver Aluminum	689
LBL	Dark Bronze	690
DBL	Light Bronze	691
FBL	Black	693
GBL	Satin Brass	696
Plated finishes available on arms and full metal cover.		
US3	Bright Brass	605
US4	Satin Brass	606
US9	Bright Bronze	611
US10	Satin Bronze	612
US26	Bright Chromium Plated	625
US26D	Satin Chromium Plated	626

For split finish of closer cover and arm, specify cover finish first, then arm finish (e.g., DC6200 x 625 x 689).

Certification/Compliance



Barrier-Free Code Compliance

The DC6000 Series Door Closers listed below conform to the 5 lbf. maximum door opening force requirement for non-fire-rated interior hinged doors, according to:

Americans with Disabilities Act (ADA)
Complies with the Accessibility Guidelines for Buildings and Facilities, Section 4.13.11

ANSI/BHMA

Meets A156.4, Grade 1.
Meets A117.1.

DC6200	DC6412
DC6210	DC6421
DC6220	DC6401
DC6411	

These door closers are certified by Corbin Russwin Architectural Hardware to comply with the above standards when properly installed and (if applicable) adjusted, in regular arm, parallel arm and top jamb mountings.

UL/ULC/UL10c

Listed for fire and cycle requirements.

DC6200 - Multi-Sized
DC6400 - Sizes 1-6, half-size adjustable

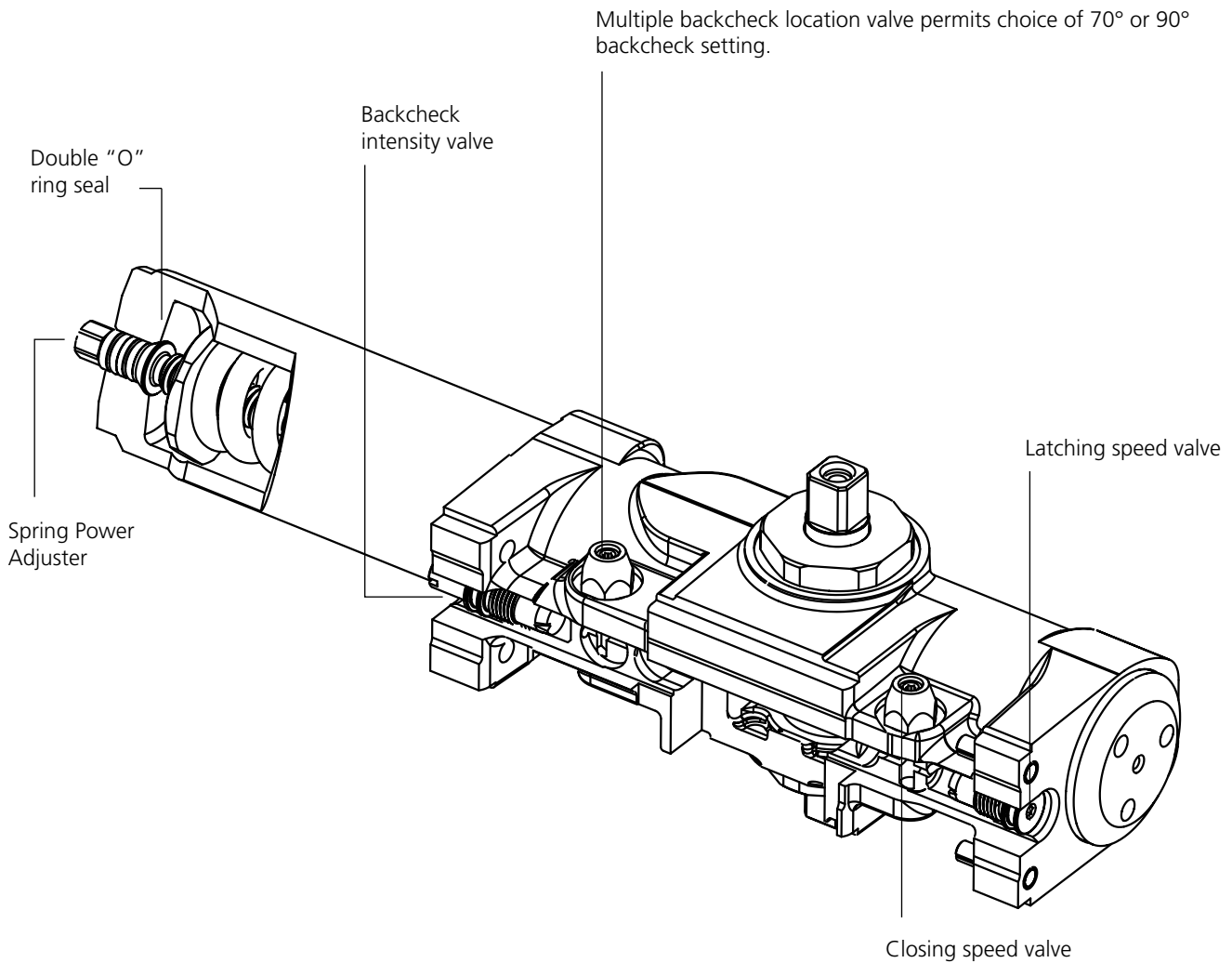

Quik-Install™ mounting bracket included, see p11

Mountings and Applications

DC6000



Regular Arm Mounting DC6200, DC6400 Series

Most common mounting, providing the greatest closing efficiency. Closer is mounted on the pull side, with the arm almost perpendicular to the face of the door. Arm bracket is attached to the door frame.



Parallel Arm Mounting DC6210, DC6410 Series

Allows inside application of closer on out-swinging doors. Closer is mounted on the push side, with the arm almost parallel to the face of the door. Arm does not project from the opening.



Top Jamb Mounting DC6220, DC6420 Series

Closer is mounted on the frame on the push side, with the arm perpendicular to the face of the door. Arm bracket is mounted on the door. Minimum 1-3/4" (44mm) top jamb required. Accommodates reveals up to 3-1/4" (83mm).



Track Mounting DC6230, DC6430 Series

Closer is top jamb mounted on the pull side; arm is connected to a door-mounted track. Maximum degree of opening is 110°. Maximum closing power is size 4. Minimum 3" (76mm) frame face required.



Track Mounting DC6240, DC6440 Series

Closer is mounted on push side of door; arm is connected to a stop-mounted track. Maximum degree of opening is 110°. Maximum closing power - size 4.

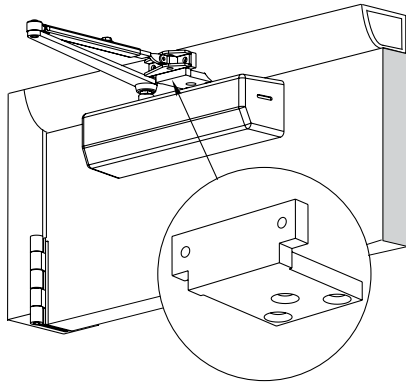

Regular Arm Mounting with Mortise Arm Bracket

Used on inadequately reinforced frames, such as those with bull nose trims.

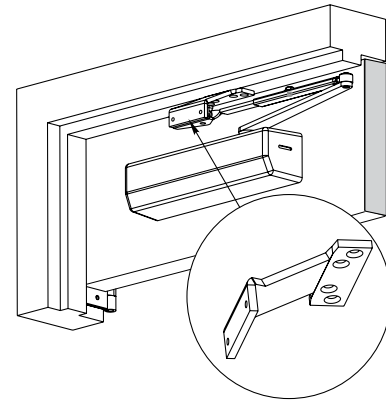

Parallel Arm with Offset Angle Bracket Mounting

Allows parallel arm mounting when used with an overhead door holder.

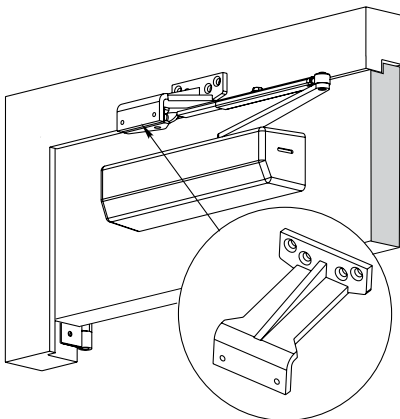

Parallel Arm Mounting with Flush Transom Bracket

Allows parallel arm mounting on flush transom applications.

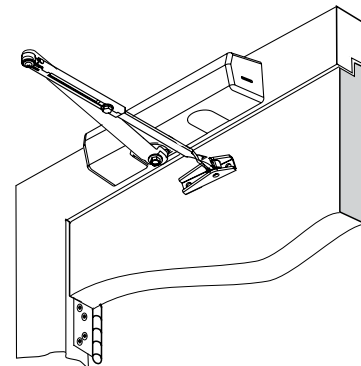

Top Jamb Flush Transom Mounting

Closer is top jamb mounted on the push side; arm is attached to the door.

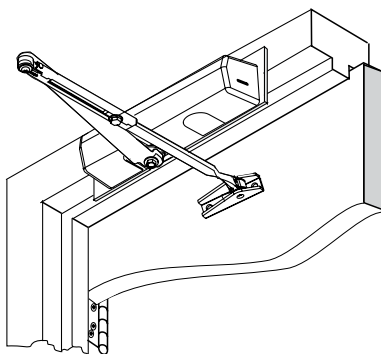

Narrow Frame Mounting

For use when the frame is too narrow for a normal top jamb or top jamb track mounting. (Shown with 188F65 drop plate)

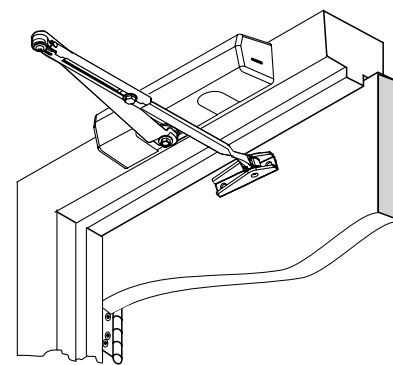

Top Jamb Deep Reveal Mounting

For reveals greater than 3-1/4" (83mm), up to 7-1/4" (184mm).

Arm Options

DC6000

**688F95
(Non-Hold Open)**

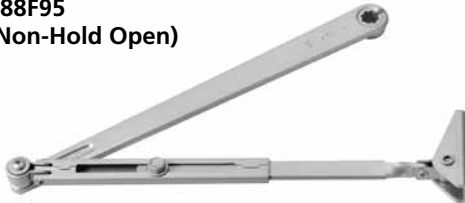

**688F77
(Hold Open)**



**691F72
(Non-Hold Open)**



**597F52
(Non-Hold Open Only)**

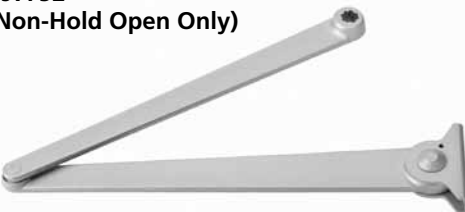

**688F95 x 188F41
(Non-Hold Open)**

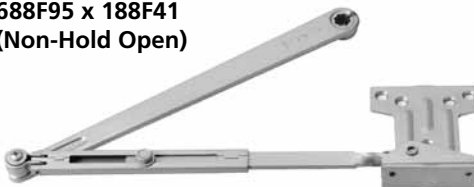

**688F77 x 509F49
(Hold Open)**



Regular Arm

- Used with regular arm (pull side) and top jamb (push side) mounting
- Available in painted or plated finishes
- Non-hold open arm standard on the DC6200 and DC6400 closers
- Hold open arm optional, specify closer x **A1***

Deep Reveal Arm (3-3/8" (86mm) - 7-1/4" (184mm))

- Accommodates top jamb mounting for reveals up to 7-1/4" (184mm), depending on door and frame conditions
- Mounted on push side
- Available in painted or plated finishes
- Optional on DC6220 and DC6420 closers
- Non-hold open, specify closer x **A6**
- Hold open, specify closer x **A8***

Non-Hold Open	691F72
Hold Open	691F74

Heavy-Duty Regular Arm

- Recommended for high-use, high-abuse environments
- Tamper-resistant, solid forged steel riveted arm
- Mounted on pull side
- Not available in plated finishes
- Optional on DC6200 and DC6400 closers, specify closer x **A10**

Parallel Arm

- Mounted on push side
- Non-hold open arm – combines regular arm with parallel arm mounting bracket
- Available in painted or plated finishes
- Hold open arm – combines regular hold-open arm with parallel arm mounting bracket
- Non-hold open arm standard – order DC6210 or DC6410 series
- Hold open arm optional, specify closer x **A1***

Specify finish when ordering arms. *Not allowed by code on fire doors.

**689F02
(Non-Hold Open)**



**689F01
(Hold Open)**



Heavy-Duty Parallel Arm

- Recommended for high-use, high-abuse environments
- Tamper-resistant, solid forged steel riveted arm
- Mounted on push side
- Not available in plated finishes
- Optional on DC6210 and DC6410 closers
- Non-hold open arm, specify closer x **A3**
- Hold open arm, specify closer x **A2***. Hold-open range 85° to 110°
- For use with overhead stops, specify closer x **A13** (see page 10)

**689F03
(Non-Hold Open)**



**689F04
(Hold Open)**



Heavy-Duty Reversible Backstop Parallel Arm

- Recommended for high-use, high-abuse environments
- Tamper-resistant, solid forged steel riveted arm
- Mounted on push side
- Not available in plated finishes
- Optional on DC6210 and DC6410 closers
- Field-reversible steel lug restricts degree of opening to protect door, wall and hardware
- Shipped standard as left hand. Handing can be reversed in the field
- Non-hold open arm, specify closer x **A4**. Door stop range 85° to 110°
- Hold open arm, specify closer x **A5***. Door stop/hold open range 85° to 110°

(Non-Hold Open)



(Hold Open)



Heavy-Duty Spring Stop Parallel Arm

- Recommended for high-use, high-abuse environments
- Integrates a door closer, shock absorber and auxiliary heavy-duty overhead stop
- Not available in plated finishes
- Hold open*
 - Holder mechanism tension adjustable
 - Hold open can be engaged/disengaged with a 1/4 turn of the mechanism with a standard blade type screwdriver
- Optional on DC6210 and DC6410 closers
- Non-hold open arm, specify closer x **A11 x door width**. Door stop range 85° to 110°.
- Hold open arm, specify closer x **A12* x door width**. Door stop/hold open range 85° to 110°.

Refer to page 12 for bracket information

Specify finish when ordering arms.

*Not allowed by code on fire doors.

Door Width	Model Number	
	Non-Hold Open	Hold Open
28" - 32" (71cm - 81cm)	615F52	615F51
33" - 41" (84cm - 104cm)	615F54	615F53
42" - 48" (107cm - 122cm)	615F56	615F55

Arms and Brackets

DC6000

691F96 (Non-Hold Open)

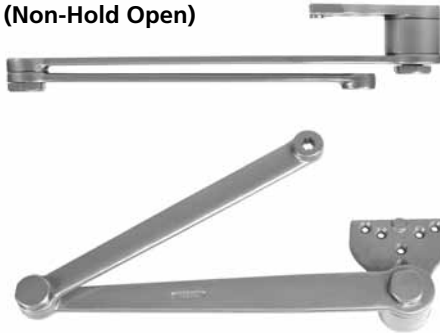

Heavy-Duty Extra Clearance Parallel Arm

- Recommended for high-use, high-abuse environments
- Provides additional vertical clearance
- Mounted on push side
- Not available in plated finishes
- Optional on DC6210 and DC6410 closers
- Non-hold open arm only, specify closer x **A13**

Standard Clearance	Closer	With Spacer	Quick Code	Total Clearance
1-3/4"	DC8210	597F92	M77	2-1/4"
		597F93	M78	2-3/8"



Heavy-Duty Parallel Hold Open Arm

- Recommended for high-use, high-abuse environment
- Requires auxiliary stop (by others)
- Handed
- Mounted on push side
- Not available in plated finishes
- Allows door to swing 180°, conditions permitting
- Optional on DC6210 and DC6410 closers
- Hold open arm, specify closer x **A14***

Part Number	Handing
692F04	Right Hand
692F05	Left Hand

754F44 Shown



Pull Side Track Arm

- Provides a clean aesthetic look with maximum 110° door swing and a minimum door width of 28" (71cm)
- Mounted on pull side
- Not available in plated finishes
- Non-hold open standard on DC6230 or DC6430 closers
- Hold open, specify closer x **A1***
- Hold open function can be turned on or off using a standard blade screw driver
- Stop/Hold open can be set for 85°, 90°, 95°, or 100°

	Track and Arm	Track Only	Arm Only
Non-Hold Open	754F44	754F09	754F16
Hold Open	754F45	754F10	

754F13 Shown



Push Side Track Arm

- Clean aesthetic look for doors opening a maximum of 110° and a minimum door width of 32" (81cm)
- Mounted on push side
- Not available in plated finishes
- Non-hold open standard on DC6240 and DC6440 closers. For hold open, specify closer x **A1***
- Stop/hold open can be set for 85°, 90°, 95° or 100°
- Hold open function can be turned on or off using a standard blade screw driver

	Track and Arm	Track Only	Arm Only
Non-Hold Open	754F12	754F14	754F16
Hold Open	754F13	754F15	

Specify finish when ordering arms or tracks.
*Not allowed by code on fire doors.

188F03



Quik-Install™ Mounting Bracket

- Standard on all closers
- Reduces installation time
- Ensures correct mounting
- Bracket is first mounted to door or frame, then closer is attached
- Bracket size: 1-3/4" (44mm) (vertical) x 6" (152mm) (horizontal)
- Hole spacing: 1" (25mm) (vertical) x 4-5/16" (110mm) (horizontal)

244F17



Mortise Arm Bracket for Regular Arm Mounting

- For regular arm mounting where frame requires reinforcement, i.e., on frames with bull nose trim
- Not available in plated finishes
- Specify closer x M84

188F41



Parallel Arm Non-Hold Open Bracket

- Converts regular arm to parallel arm closer
- Standard with DC6210 and DC6410 closers
- Packed with five screws and 691F78 spacer

509F49



Parallel Arm Hold Open Bracket

- Converts regular arm hold open to parallel arm hold open closer
- Standard with DC6210 x A1 or DC6410 x A1 closer

188F62



Parallel Arm Offset Bracket

- Required when parallel arm is used in conjunction with an overhead door holder
- Specify DC6210 x M83 or DC6410 x M83 closer

188F63



Parallel Arm Flush Transom Bracket

- Required when parallel arm mounting is used on a flush transom application
- Not available in plated finishes
- Specify DC6210 x M82 or DC6410 x M82 closer

Specify finish when ordering parts.

Brackets

DC6000

499F30



Flush Transom Bracket

- Available separately for mounting A2, A3, A4, A5, A13 and A14 heavy-duty arms on rabbeted or flush transom conditions
- Not available in plated finishes
- Specify closer x M79

447F14

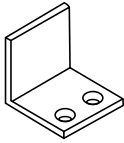

Angle Support Bracket

- Available separately for mounting A2, A3, A4, A5, A13 & A14 heavy-duty arms on narrow frame or soffit conditions
- Specify DC6210 x M85 or DC6410 x M85 closer

691F78

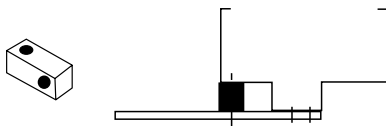

Spacer Block

- For use where a narrow frame soffit does not provide adequate surface to support the fifth arm bracket mounting hole
- Supplied standard with DC6210 and DC6410 non-hold open closers with A2, A3, A4, A5, A13 and A14 heavy-duty parallel arms

597F92 (1/2")
597F93 (5/8")



Blade Stop Spacer

- Available for use with A2, A3, A4, A5, A13 & A14 heavy-duty arms.
- Specify closer x M77 (597F92)
- Specify closer x M78 (597F93)

Maximum
Power



Normal
Power



Power Adjustment Arm Bracket

- Standard on all closers without hold open, except heavy-duty and track type
- In regular arm or top jamb mounting, bracket may be reversed to increase closing power 15%

615F58

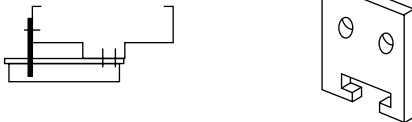

Reinforcing Bracket

- Supplied as standard for use with A11 and A12 spring stop arms
- Provides additional support to the soffit plate on installations with door frame reveals from 1-7/8" to 4-5/8" (48 to 117mm)
- Not available in plated finishes

615F59

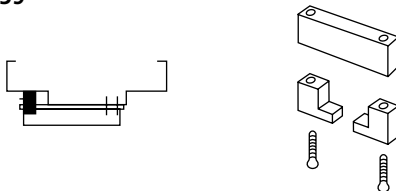

Deep Reveal Reinforcement Kit

- For use with A11 and A12 spring stop arms
- Used to support the soffit plate on installations with deep frames. Clamps may be used with or without the spacer block, depending on frame conditions
- Not available in plated finishes
- For frames deeper than 4-5/8" (117mm), specify closer x M103

615F60

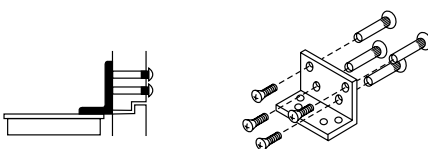

Flush Partition Bracket

- For use with A11 and A12 spring stop arms where rabbeted or flush transom conditions prevent installation of the soffit plate assembly
- Bracket fastens to the overhead transom to provide a mounting surface for the soffit plate assembly
- Specify DC6210 x M104 or DC6410 x M104 closer

Specify finish when ordering parts.

597F78



Full Cover

- Standard on all DC6000 series door closers
- Completely covers closer body
- Non-handed
- Dimensions: 11-5/8" (295mm) x 3" (76mm) x 2-3/4" (70mm) deep
- Available in painted finishes only
- Flame rated V-O material compliant with UL10C

Full Metal Cover

- For use in high-abuse applications or when an architectural plated finish is desired
- Specify hand; not field reversible
- Available in painted and plated finishes
- Dimensions: 11-1/2" (292mm) x 2-7/8" (73mm) x 2-3/4" (70mm) deep



Part Number	Handing
603F55	RH/LHR
603F57	LH/RHR

Drop Plate

Permits parallel arm mounting on door when top rail is too narrow to install closer in the regular manner. Minimum 2-5/8" (67mm) top rail required. Jamb mounted where there is insufficient ceiling clearance for standard mounting or where it is necessary to allow vertical arm clearance for overhead door holders or frame gasketing. To order separately, specify Part No. x Finish.



Closer Series	Drop Plate
	With Full Cover
DC6210, DC6410	597F58
DC6220, DC6420	188F65
DC6240, DC6440	597F58

Retrofit Plates

For installation of Corbin Russwin DC6200 and DC6400 closers where doors & frames have been prepared for LCN heavy-duty surface closers. To order with closers specify Closer x Quick Code, see page 19.

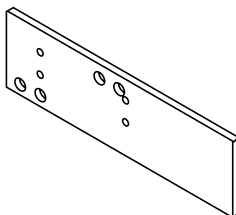

To Replace LCN Model		Model Number
4040/4041	Regular Arm	615F63
4040/4041	Parallel Arm	615F61
4110EDA	Parallel Arm	615F64
4010	Regular Arm	615F62

Door Closer Sizes

DC6000

Factors in Determining Closer Size

1 – Weight and Height of Door

Doors vary in weight from light hollow-core wood doors to heavy metal doors. Door sizes listed in the chart are based on doors of standard weight and height. Extra-light or extra-heavy weight or unusual height must be compensated for.

2 – Draft and Wind Conditions

Draft and wind conditions are perhaps the most important factors to consider in determining the closer size required. Sizes listed in the chart apply to normal conditions. Stairwells, air conditioning, building construction, and door location can cause strong draft and wind conditions; these may necessitate adjusting spring power to a larger size or using a closer one size larger.

3 – Location of Closer

The degree of door opening required determines the location of the closer on the door. Closer sizes listed in the chart are based on 180° opening.

4 – Special Conditions

Deep reveals require optional extended arms. A top jamb plate is required when the jamb is too narrow for a normal top jamb mounting.

5 – Code Compliance

A multi-sized, fully adjustable closer such as the DC6200 closer provides the greatest flexibility in balancing barrier-free access, security and life safety codes. However, when a manual closer is installed and adjusted to comply with ADA or any other reduced opening force requirements, it may no longer have sufficient power to close and latch the door reliably.

Recommended Door Closer Sizes				
Application	Door Width			Recommended Closer Size
	Interior	Exterior, In-Swinging	Exterior, Out-Swinging	
Regular or Top Jamb	2'4" (71cm)	—	—	1
	3'0" (91cm)	—	—	2
	3'6" (107cm)	2'6" (76cm)	3'0" (91cm)	3
	4'0" (122cm)	3'0" (91cm)	3'6" (107cm)	4
	4'6" (137cm)	3'6" (107cm)	4'0" (122cm)	5
	5'0" (152cm)	4'0" (122cm)*	4'6" (137cm)*	6
Parallel Arm	2'4" (71cm)	—	—	1
	2'6" (76cm)	—	—	2
	3'0" (91cm)	—	2'6" (76cm)	3
	3'6" (107cm)	—	3'0" (91cm)	4
	4'0" (122cm)	—	3'6" (107cm)*	5
	4'6" (137cm)	—	4'0" (122cm)*	6

* Due to half-size adjustability, the DC6400 Series is recommended.

Handing

Refers to the direction a door swings; always determined from the outside of the door.

Regular Mounting

Door: left hand
Closer: left hand pull side

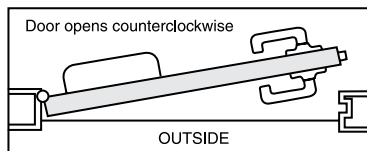

Door: right hand
Closer: right hand pull side

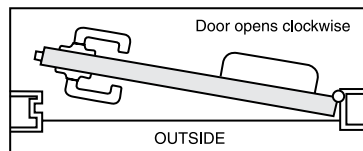

Parallel Arm Mounting

Door: left hand reverse bevel
Closer: right hand push side

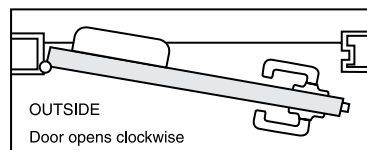

Door: right hand reverse bevel
Closer: left hand push side

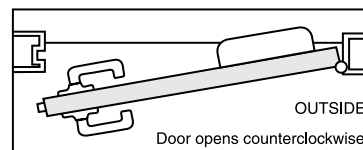

Top Jamb Mounting

Door: left hand reverse bevel
Closer: right hand push side

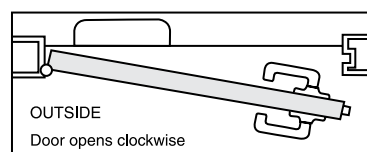

Door: right hand reverse bevel
Closer: left hand push side

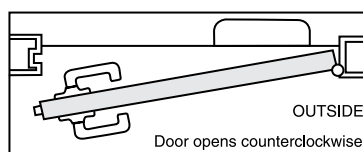

Helpful Terms

DC6000

Backcheck

Slows a door at approximately 70° of the opening cycle, by providing cushioned resistance to a forceful opening. Designed to protect people and objects behind the door and to prevent damage to the closer, hardware, and wall. Intensity can be increased or decreased. Not intended to act as a stop.

Backcheck Location

The point (approximately 70°) in the opening cycle where backcheck takes effect.

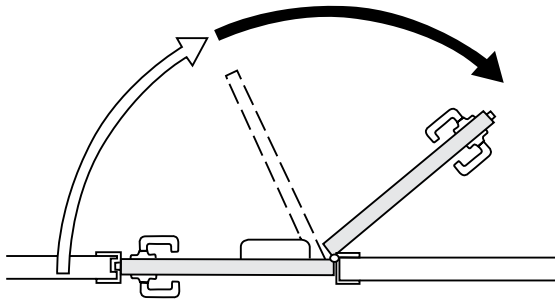

Closing Speed

The speed at which a door swings from the full open position to within a few degrees of latching. See Latching Speed.

Corrosion Protection

Additional painted covering on all external parts to deter oxidation and corrosion.

Delayed Action

Slows door closing speed between maximum opening and approximately 70°. Often specified to meet barrier-free codes which require longer closing times. Also used in high traffic situations (auditoriums, classrooms, etc.) or when carts and gurneys are pushed through the doors.

Door Stop

A device to stop the swing of a door.

Hold Open

Maintains door at a particular degree of opening. A mechanical hold open may not be used on labeled fire doors, which must be self-closing.

Multi-Sized Closer

A closer whose spring design allows full adjustment of the spring power size from 1 through 6.

Latching Speed

The speed of the door during the last few degrees of closing. Allows latching and prevents slamming.

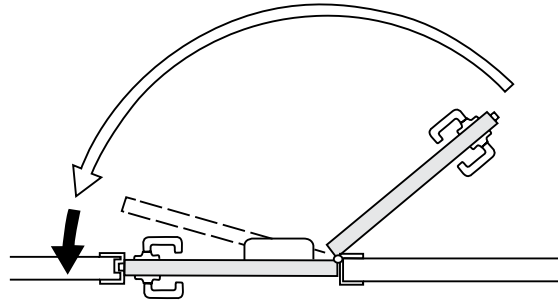

Mounting

The method by which a closer is attached to the door and frame.

Multiple Backcheck Location Valve

Valve that changes the degree of door angle where backcheck occurs.

Quik-Install™ Mounting Bracket

Unique bracket which simplifies installation and minimizes installer fatigue.

Sex Nuts and Bolts (SNBs)

Through-bolts required for all non-steel-reinforced fire doors, and recommended for non-reinforced wood and mineral core doors.

Sized Closer

A closer whose spring design allows for a fixed spring power size 1 through 6.

Spring Power

A measurement of closing force, or the ability to overcome draft, air pressure, weight or other resistance to door closing.

Star Punch

An eight-point hole in the closer arm, permitting spindle pre-loading. Provides full functioning of backcheck and delayed action valves.

Universal Mounting

The ability of a closer to accommodate either hand for regular, top jamb or (using a bracket) parallel arm mounting.

Ordering Examples

Stock

Quantity	Series/Mounting/Size	Finish	Misc. Options
50	DC6210	689	M54

Where to find ordering information and quick codes

Series/Mounting/Size	Page 17
Arm	Page 18
Finish	Page 18
Handing	Page 18
Door Thickness	Page 18
Miscellaneous Options	Page 19

Job Specific

Quantity	Series/ Mounting/Size	Finish	Hand	Thickness	Options
50	DC6413	626	RH	D138	M71-M73

Split Finish

Quantity	Series/Mounting/Size	Finish		Hand	Misc. Options
		Cover	Arm		
10	DC6210	626	689	RH	M54

Note:

- Door closer warranty becomes void if it is installed on the exterior side of a door in the exterior wall of a building
- It is strongly recommended, and it is required on fire door assemblies, that doors having a door closer be hung on ball-bearing or anti-friction hinges or pivots
- Failure to use the correct type and size fasteners may void factory warranty
- Fasteners for fire/smoke door assemblies must conform to NFPA 80. In some applications additional fasteners may be mandated by NFPA 80 that are not shipped with Corbin Russwin's standard product, such as sleeve-units/sex nuts or through-bolts and grommet nuts

Series/Mounting/Size

Description	Mounting	Non-sized	Size 1 Specify	Size 2 Specify	Size 3 Specify	Size 4 Specify	Size 5 Specify	Size 6 Specify
DC6200 Closers Multi-sized; full adjustability from size 1-6	Regular arm	DC6200	—	—	—	—	—	—
	Parallel arm	DC6210	—	—	—	—	—	—
	Top jamb	DC6220	—	—	—	—	—	—
	Track (Pull Side)	DC6230	—	—	—	—	—	—
	Track (Push Side)	DC6240	—	—	—	—	—	—
DC6400 Closers Sized; 1/2-size adjustability	Regular arm	—	DC6401	DC6402	DC6403	DC6404	DC6405	DC6406
	Parallel arm	—	DC6411	DC6412	DC6413	DC6414	DC6415	DC6416
	Top jamb	—	DC6421	DC6422	DC6423	DC6424	DC6425	DC6426
	Track (Pull Side)	—	—	—	DC6433	DC6434	DC6435	DC6436
	Track (Push Side)	—	—	—	DC6443	DC6444	DC6445	DC6446

Quick Codes

DC6000

Arm

Arm	Specify Quick Code
Regular non-hold open	(standard)
Hold open	A1*
Heavy-duty parallel with hold open	A2*
Heavy-duty parallel non-hold open	A3
Heavy-duty backstop non-hold open	A4
Heavy-duty backstop with hold open	A5*
Deep reveal (3-3/8" -7-1/4")	A6
Deep reveal with hold open	A8*
Heavy-duty regular non-hold open	A10
Spring stop non-hold open (specify door width)	A11
Spring stop heavy-duty with hold open (specify door width)	A12*
Heavy-duty parallel arm with extra clearance	A13
Heavy-duty friction hold open arm (specify hand)	A14*
Push side track with hold open	A1*

***Hold open arms cannot be used on fire doors.**

Handing

Hand	Specify
Left Hand/Right Hand Reverse	LH
Right Hand/Left Hand Reverse	RH

Blade Stop

Spacer	Specify Quick Code
1/2"	M77
5/8"	M78

Torx® Tool Kit Package

Description	Specify
Bits and driver	597F24

Finish

Standard painted finishes

Old Designation	Description	Specify Quick Code
USP	Primed for Painting	600
SBL	Silver Aluminum Painted	689
LBL	Dark Bronze Painted	690
DBL	Light Bronze Painted	691
FBL	Black Painted	693
GBL	Satin Brass Painted	696

Plated finishes available on arms and full metal cover

US3	Bright Brass	605
US4	Satin Brass	606
US9	Bright Bronze	611
US10	Satin Bronze	612
US26	Bright Chromium Plated	625
US26D	Satin Chromium Plated	626

For split finish of closer cover and arm, specify cover finish first, then arm finish (e.g., DC6200 x 625 x 689).

Door Thickness

Door Thickness	Specify
1-3/4" (44mm)	(standard)
2" (51mm)	D200
2-1/4" (57mm)	D214

Miscellaneous Options

Description		Specify Quick Code
Torx® machine screws		M04
Sex nuts and bolts (SNBs) (1-3/4" minimum thickness)		M54
Backcheck intensity and location valves		(standard)
Delayed action		M71
Full cover		(standard)
Full metal cover (Handed)		M73
Extreme temperature fluid		(standard)
Corrosion protection		M75
1/2" spacer		M77
5/8" spacer		M78
Drop plates - order by number (formerly M80, M81 and M102 quick codes)		
Closer Series	Old Quick Ship #	Drop Plate With Full Cover
DC6210, DC6410 (Parallel)	M80	597F58
DC6220, DC6420 (Top Jamb)	M80	188F65
DC6230, DC6430 (Pull Side)	M81	597F59
DC6240, DC6440 (Push Side)	M102	597F59
Heavy-duty parallel arm flush transom bracket (499F30) used with A2, A3, A4, A5, A13 & A14 arms		M79
Parallel arm flush transom bracket (parallel or A1)		M82
Parallel arm offset bracket		M83
Mortise arm bracket (for regular arm mounting)		M84
Angle support bracket		M85
Spacer (691F78) (formerly M86 quick code)		(standard)
Security package (available with A2, A3, A4, A5 and A10 optional arms). Covers are handed.		M87
Retrofit kit LCN 4041 RA or PA		M101B
Retrofit kit LCN 4110EDA		M101C
Retrofit kit LCN 4010		M101D
Deep reveal reinforcement kit (available with A11 & A12 arms)		M103
Flush partition bracket (available with A11 & A12 arms)		M104
Lead-lined metal cover		M108

Specifications

DC6000

ANSI A156.4 Certified Closer Cross Reference

ANSI Number	Function	Series	PT 4A 15% Power Adjustment	PT 4B 35% Power Adjustment	PT 4C 50% Power Adjustment	PT 4D Adjustable Backcheck	PT 4F Delayed Action	PT 4G Dead Stop	PT 4H Fully Adjustable
CO2011 (PT 1)	Hinge Side Mounting	DC6200	S	S	S	S	O	N/A	S
		DC6400	S	S	S	S	O	N/A	N/A
CO2051 (PT 1)	Hinge Side Mounting	DC6200-A1	S	S	S	S	O	N/A	S
		DC6400-A1	S	S	S	S	O	N/A	N/A
CO2021 (PT 1)	Parallel Arm Mounting	DC6210	S	S	S	S	O	O	S
		DC6410	S	S	S	S	O	O	N/A
CO2061 (PT 1)	Parallel Arm Mounting	DC6210-A1	S	S	S	S	O	O	S
		DC6410-A1	S	S	S	S	O	O	N/A
CO2041 (PT 1)	Top Jamb Mounting	DC6220	S	S	S	S	O	N/A	S
		DC6420	S	S	S	S	O	N/A	N/A
CO2081 (PT 1)	Top Jamb Mounting	DC6220-A1	S	S	S	S	O	N/A	S
		DC6420-A1	S	S	S	S	O	N/A	N/A
CO2231 (PT 1)	Push Side Mounting	DC6240	S	S	S	S	O	O	S
		DC6440	S	S	S	S	O	O	N/A
CO2241 (PT 1)	Push Side Mounting	DC6240-A1	S	S	S	S	O	O	S
		DC6440-A1	S	S	S	S	O	O	N/A
CO2251 (PT 1)	Pull Side Mounting	DC6230	S	S	S	S	O	O	S
		DC6430	S	S	S	S	O	O	N/A
CO2261 (PT 1)	Pull Side Mounting	DC6230-A1	S	S	S	S	O	O	S
		DC6430-A1	S	S	S	S	O	O	N/A

ANSI Performance Requirements: (PT 1) — 2,000,000 cycles — closer without backcheck feature.

ANSI Performance Requirements: (PT 1) — 1,500,000 cycles — closer with backcheck feature.

N/A = not available S = standard O = option available

ANSI Options:

DC6200 includes PT4-A, B, C, D, H. Optional: PT4-F, G, J.

DC6400 includes PT4-A, B, C, D. Optional: PT4-F, G, J.

Suggested Specification

Door closers shall be of rack and pinion construction with a cold headed heat-treated steel spindle and a steel piston precision machined and heat treated. The case shall be of cast iron with seamless cold headed steel spring tube. A two-piece or seamed spring tube shall not be acceptable. Springs shall be tempered chrome silicon. Closers shall have a heavy-duty, forged steel main arm.

Optional arms shall include parallel, hold open, heavy-duty, heavy-duty hold open, heavy-duty reversible backstop, heavy-duty reversible backstop with hold open, heavy-duty spring stop, heavy-duty spring stop with hold open, deep reveal, top jamb track and stop mounted track.

The following size options shall be available:

- Fully adjustable spring power to accommodate sizes 1 through 6.
- Spring power shall be adjustable by one half size over minimum for each size.

All sizes shall be accommodated in one closer body. Closing shall be controlled by two valves — one to control closing speed and one to control latching speed. Valves shall be concealed against unauthorized adjustment and be non-critical with "O" ring seals.

(Door closers shall have an adjustable delayed action feature, controlled by a separate valve.)

Closers shall be furnished with an adjustable backcheck intensity valve. Valve shall be accessible without removing the closer from the door.

Closers shall be furnished with a backcheck location valve, providing a choice of locations where backcheck begins in the door opening cycle between 70° and 90° of door opening. This valve shall be functional for all regular, top jamb, parallel arm, and track type mountings.

Closers shall be surface applied with rectangular cover, and shall be devoid of manufacturer's trademarks. Closers shall not project over 2³/₄" , and shall be capable of mounting on 1-3/4" top rail or inverted mounting on 1³/₄" top jamb. Full cover and full metal cover with security fasteners shall be available. When required, metal covers shall be available in plated finishes. Regular arm and top jamb mounted closers without hold open shall be regularly furnished with power adjustment arm bracket capable of providing a 15% power adjustment. A Quik-Install™ mounting bracket to attach the closer shall be regularly furnished. Closers not having a mounting bracket shall not be acceptable. Hydraulic fluid shall be of a type requiring no seasonal valve readjustment due to extreme temperature variations. Closers mounted top jamb and parallel arm shall allow for full 180° door opening.

Closers with non-hold open arms shall be listed by Underwriters Laboratories for swinging fire doors and for positive pressure listed openings.

All closers shall be available in architectural finishes to match corresponding door hardware.

Certification:

ANSI/BHMA A156.4, Grade 1

ADA/ANSI A117.1

UL10C and UBC

Closers shall carry a ten-year limited warranty.

Closers shall be Corbin Russwin (DC6200) (DC6400) series.

Notes

DC6000



ASSA ABLOY

In U.S.

Corbin Russwin
Architectural Hardware
225 Episcopal Road
Berlin, CT 06037
Phone: 800-543-3658
Fax: 800-447-6714
www.corbinruswin.com

In Canada

ASSA ABLOY Door
Security Solutions Canada
160 Four Valley Drive
Vaughan, Ontario
Canada L4K 4T9
Phone: 800-461-3007
Fax: 905-738-2478 www.assaabloy.ca

For more information regarding Corbin Russwin Locksets, Exit Devices, Door Controls and Key Systems, contact your authorized Corbin Russwin Distributor or Sales Representative.

Corbin Russwin and Design® is a registered trademark of Corbin Russwin, Inc., an ASSA ABLOY Group company. Quik-Install™ is a trademark of Corbin Russwin, Inc., an ASSA ABLOY Group company. Other products' brand names may be trademarks or registered trademarks of their respective owners and are mentioned for reference purposes only. These materials are protected under US copyright laws. All contents current at time of publication. Corbin Russwin, Inc. reserves the right to change availability of any item in this catalog, its design, construction, and/or its materials. Copyright © 2004, 2011 Corbin Russwin, Inc., an ASSA ABLOY Group company. All rights reserved. Reproduction in whole or in part without the express written permission of Corbin Russwin, Inc. is prohibited.

ASSA ABLOY is the global leader in door opening solutions, dedicated to satisfying end-user needs for security, safety and convenience.