

GRJ930 Kit Installation Instructions for Cutter blade and Backing Plate

Components of this kit are a dimensionally matched set. You may have parts that look similar, but they are different dimensionally if received before May 1, 2004. Parts received before May 1, 2004 should be discarded.

1. Remove old cutter blade screws, cutter blade and backing plate and discard.
2. See illustrations to determine the correct positions for component assembly.
3. Hold cutter blade and backing plate together, insert screws and tighten to 8-14 ft-lbs.
4. Choose the correct length bolts supplied in this kit for your tool. Fully tensioned bolts should flush or extend beyond the cutter blade ¼" max.

Operating Tip: Keep the bolts tight (8-14 ft-lbs.). A loose bolt may cause cracking or premature wear of the cutter blade and/or backing plate. This could result in improper clamp tensioning, locking, and cutting.

Operating Tip: Keep the leading edges of the cutter blade and backing plate free of metal shavings. Metal shavings will result in clamp tail gouging during tensioning. **Clean and hone the leading edges by hand. Do not use power tools. Honing should polish surfaces, not remove material.**

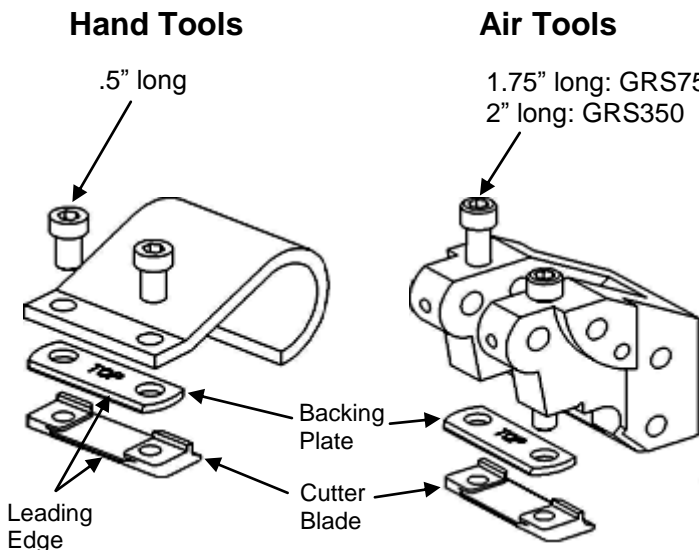

CAUTION: To prevent breakage, backing plate must be installed flush with cutter blade.

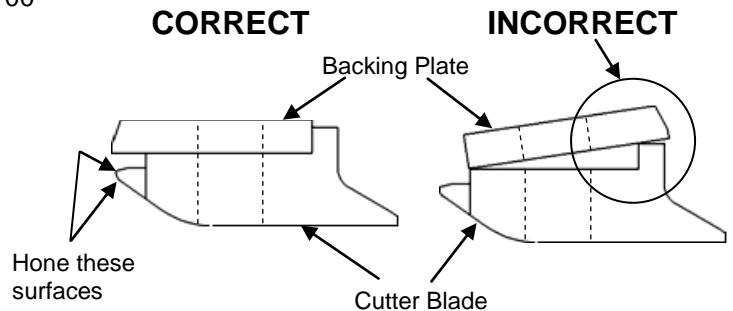

Rough edges on clamp band are indication of need to hone cutter blade.

