

FVX and FVMX Commercial T&P Relief Valves

DESCRIPTION

The Cash Acme FV(M)X Series combination temperature and pressure relief valves are designed to offer high capacity protection for domestic and commercial water heating devices.

The Cash Acme FV(M)X Series is fully automatic, and the valves reseal after either temperature or pressure relief.

The FV(M)X Series Valves are diaphragm guided, and they are suitable for installations where codes require complete shut-off. The larger FV(M)X Series Valves are well suited for such commercial applications as restaurants, hospitals, and laundries. Available sizes include 3/4", 1", 1-1/4", 1-1/2" and 2". The FV(M)X Series offers a choice of either male (designated FVMX) or female (designated FVX) inlet connections.

A variety of extension thermostat lengths are available to place the element in the hottest water without restricting flow. Extended length bodies are available for several sizes to accommodate applications with thick insulation. Consult the dimension table for details.

All Cash Acme FV(M)X Series Valves through 1-1/4" have coated thermal elements to protect against corrosion and mineral build-up. The coating also isolates the copper from galvanic action within the heater. The 1-1/2" and 2" sizes are fitted with stainless steel thermal elements. The temperature relief setting is 210°F (99°C).

The FV(M)X Series Valves have a standard factory pressure relief setting of 150 psi. Most models are also available with a pressure relief setting in the range of 75 psi to 150 psi.

Lead Free* versions of most models are also available.

FEATURES AND BENEFITS

Offers high capacity protection for domestic and commercial hot water heating devices:
Handles more volume with just one relief valve.

Completely automatic:
The valves reseal after either temperature or pressure relief.

The larger series valves are well suited for commercial applications:
Restaurants, hospitals, and laundries are no problem!

Listed by CSA (ANSI Z21.22/CSA 4.4) and the National Board (ASME Boiler Code Section IV):
Inspector friendly, peace of mind!

SPECIFICATION

A temperature and pressure relief valve shall be installed to protect the water heater or water storage tank from excessive temperature or pressure. The valve shall be ASME and CSA listed and shall be design certified per ANSI Z21.22/CSA 4.4. The valve shall have a BTU rating in excess of the heat input rating of the water heater into which it is installed. The valve shall be a Cash Acme FVX or FVMX T&P Relief Valve.



* A device is defined as Lead Free if its normally wetted surface has a weighted average lead content not exceeding 0.25%.



FVX and FVMX Commercial T&P Relief Valves

TYPICAL INSTALLATION

Practically all recognized authorities state that a temperature actuated relief valve must be installed in such a manner that the temperature sensing element is in contact with hot water in the top six inches of the tank. This is a necessary safety precaution because of temperature stacking - the term given to the condition of temperature variation between the hottest water in the top of the tank and water temperatures at varying levels within the tank. The discharge from the relief valve must be conducted to a suitable place for disposal when relief occurs by installation of an appropriate drain line in accordance with applicable codes.

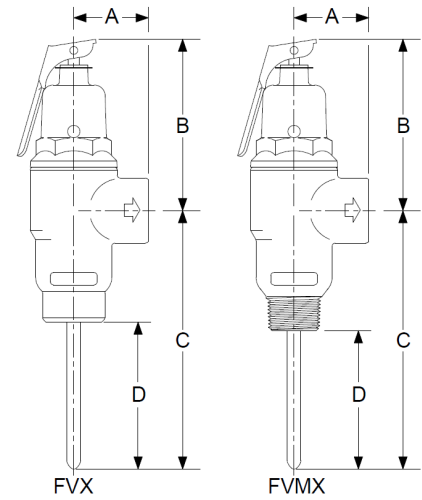
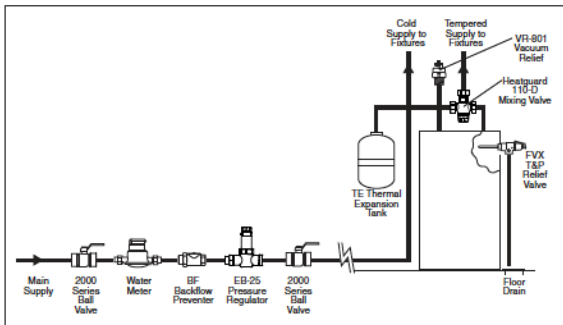

FVX Series (Female Inlet)

Type	Inlet Size (NPS) Female	Outlet Size (NPS) Female	DIMENSIONS			
			A	B	C	D
FVX-3C	3/4"	3/4"	1-1/2"	3-15/32"	5-7/32"	3"
FVX-5C	3/4"	3/4"	1-1/2"	3-15/32"	6-7/8"	4-5/8"
FVX-8C	3/4"	3/4"	1-1/2"	3-15/32"	10-1/8"	7-7/8"
FVX-3C	1"	1"	1-9/16"	3-15/32"	5-7/32"	3-3/32"
FVX-5C	1"	1"	1-9/16"	3-15/32"	6-7/8"	4-3/4"
FVX-5L	1"	1"	1-3/4"	4-3/8"	5-7/8"	4-3/4"
FVX-8L	1"	1"	1-3/4"	4-3/8"	9-1/4"	8-5/32"
FVX-4	1-1/2"	1-1/2"	2-1/2"	5-7/8"	5-7/8"	4-3/16"

SPECIFICATION DATA

Performance:

Available Set Pressures 75-150 psi
 Temperature Relief 210°F
 Service Hot water

Materials:

Body Brass
 Internal Parts Brass and stainless steel
 Seat Disc Silicone
 Pressure Spring Stainless steel
 Diaphragm EP

AVAILABLE CONNECTIONS

Threaded (NPT) Male or female inlet and female outlet

FVMX Series (Male Inlet)

Type	Inlet Size (NPS) Male	Outlet Size (NPS) Female	DIMENSIONS			
			A	B	C	D
FVMX-3C	3/4"	3/4"	1-1/2"	3-15/32"	5-7/32"	2-25/32"
FVMX-5C	3/4"	3/4"	1-1/2"	3-15/32"	6-7/8"	4-7/16"
FVMX-8C	3/4"	3/4"	1-1/2"	3-15/32"	10-1/8"	7-11/16"
FVMX-1LS	3/4"	3/4"	1-17/32"	3-15/32"	5-7/32"	1-15/32"
FVMX-5LS	3/4"	3/4"	1-17/32"	3-15/32"	9-3/32"	5-3/8"
FVMX-3C	1"	1"	1-9/16"	3-15/32"	5-7/32"	3-1/8"
FVMX-5C	1"	1"	1-9/16"	3-15/32"	6-7/8"	4-25/32"
FVMX-3LS	1"	1"	1-19/32"	3-15/32"	6-7/8"	3"
FVMX-4LS	1"	1"	1-19/32"	3-15/32"	6-7/8"	4-1/16"
FVMX-6LS	1"	1"	1-19/32"	3-15/32"	10-1/8"	6-1/4"
FVMX-4L	1-1/4"	1"	1-3/4"	4-11/32"	5-7/8"	3-29/32"
FVMX-3	2"	1-1/2"	2-15/32"	5-27/32"	5-27/32"	3-5/16"

CERTIFICATIONS

The Cash Acme FVX and FVMX Relief Valves are certified to ANSI Z21.22/CSA 4.4 and are capacity certified to ASME Boiler Code Section IV (see Rating Table).

FVX Series (Female Inlet)					
CSA (ANSI Z21.22/CSA 4.4) and ASME (Boiler Code Section IV) Ratings					
Type	Inlet Size (NPS)	CSA Rating (BTU/hr)	ASME Rating at Pressure Setting Indicated		
			75 psig (BTU/hr)	100 psig (BTU/hr)	150 psig (BTU/hr)
FVX-3C	3/4"	185,000	1,034,000	1,327,000	1,619,000
FVX-5C	3/4"	205,000	1,034,000	1,327,000	1,619,000
FVX-8C	3/4"	205,000	1,034,000	1,327,000	1,619,000
FVX-3C	1"	500,000	1,165,000	1,495,000	1,825,000
FVX-5C	1"	500,000	1,165,000	1,495,000	1,825,000
FVX-5L	1"	750,000	1,960,000	2,515,000	3,070,000
FVX-8L	1"	750,000	1,960,000	2,515,000	3,070,000
FVX-4	1-1/2"	1,200,000	3,273,000	4,199,000	5,125,000

FVMX Series (Male Inlet)					
CSA (ANSI Z21.22/CSA 4.4) and ASME (Boiler Code Section IV) Ratings					
Type	Inlet Size (NPS)	CSA Rating (BTU/hr)	ASME Rating at Pressure Setting Indicated		
			75 psig (BTU/hr)	100 psig (BTU/hr)	150 psig (BTU/hr)
FVMX-3C	3/4"	185,000	1,034,000	1,327,000	1,619,000
FVMX-5C	3/4"	205,000	1,034,000	1,327,000	1,619,000
FVMX-8C	3/4"	205,000	1,034,000	1,327,000	1,619,000
FVMX-1LS	3/4"	185,000	1,034,000	1,327,000	1,619,000
FVMX-5LS	3/4"	205,000	1,034,000	1,327,000	1,619,000
FVMX-3C	1"	500,000	1,165,000	1,495,000	1,825,000
FVMX-5C	1"	500,000	1,165,000	1,495,000	1,825,000
FVMX-3LS	1"	500,000	1,165,000	1,495,000	1,825,000
FVMX-4LS	1"	500,000	1,165,000	1,495,000	1,825,000
FVMX-6LS	1"	500,000	1,165,000	1,495,000	1,825,000
FVMX-4L	1-1/4"	750,000	1,960,000	2,515,000	3,070,000
FVMX-3	2"	1,200,000	3,273,000	4,199,000	5,125,000