

# Flared Leg Bracket Assemblies

## User Guide

### WARNING

Use safety glasses and cut-proof gloves when handling and installing brackets and signs. Install according to all FHWA, OSHA and Local regulations, where sign can be plainly viewed by drivers. Do not install in a manner which will pose a hazard to pedestrians or vehicles, or that which interferes with the readability of any other traffic sign.

### Bracket Assembly for Single Signs

Quantity	Component
2	Flared Leg Sign Brackets (see 1)
4	End Pieces (see 2)
2	36" Straps
2	Hex Head Bolts, 5/16" x 3/4"
2	Hex Head Bolts, 5/16" x 1-3/4"
2	Hex Nuts, 5/16"
2	Nylon Washers
2	Plated Washers

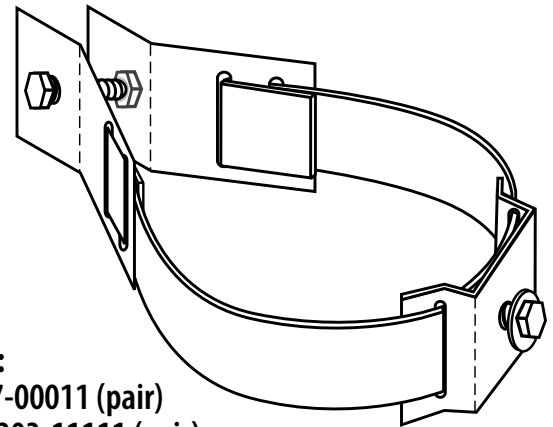

**To Order Single:**  
 Unpainted # 037-00011 (pair)  
 Painted Black # 203-11111 (pair)  
 Custom Paint # 203-11111V (pair: specify color)

#### Assembly Procedure:

1. Feed the strap through the slots of the Flared Leg Sign Bracket (1).
2. Insert one free end of the strap through one End Piece (2), feeding it first through the inside of the slot furthest from the bolt hole, then back through the other slot as shown above. Fold the strap end flat. Proper strap length will result in the End Pieces to be tightly joined in step 4.
3. Repeat Step 2 with the other end of the strap and the second End Piece.
4. Wrap the straps and end pieces around the pole. Insert the 1-3/4" hex bolt through the holes in the End Pieces. Join them with a plated washer and hex nut. Tighten until snug.
5. Repeat Steps 1-4 for the second assembly.
6. Insert one of the short (5/16" x 3/4") hex bolts through a nylon washer, through the sign's mounting hole, and then into the threaded hole in the Flared Leg Bracket. Tighten securely.
7. Repeat Step 6 for second assembly.





## FLARED LEG BRACKET ASSEMBLIES

### WARNING

Use safety glasses and cut-proof gloves when handling and installing brackets and signs. Install according to all FHWA, OSHA and Local regulations, where sign can be plainly viewed by drivers. Do not install in a manner which will pose a hazard to pedestrians or vehicles, or that which interferes with the readability of any other traffic sign.

## Bracket Assembly for Back-To-Back Signs

For mounting back-to-back signs on 4"-12" poles.

Quantity	Component
4	Flared Leg Sign Brackets (see 1)
4	End Pieces (see 2)
2	36" Straps
4	Hex Head Bolts, 5/16" x 3/4"
2	Hex Head Bolts, 5/16" x 1-3/4"
2	Hex Nuts, 5/16"
4	Nylon Washers
4	Plated Washers

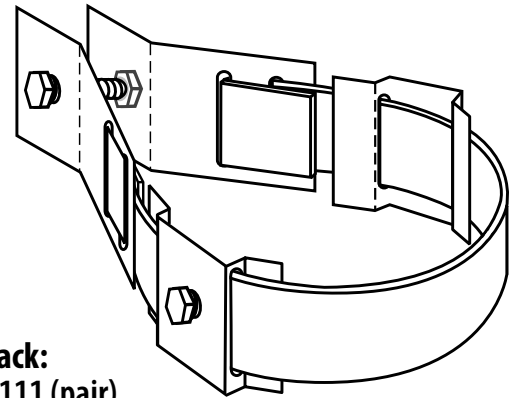

**To Order Back-To-Back:**  
Unpainted # 037-01111 (pair)  
Painted Black # 203-01121 (pair)  
Custom Paint # 203-01121V (pair: specify color)

### Assembly Procedure:

1. Feed the strap through the slots of two of the Flared Leg Sign Brackets (1).
2. Insert one free end of the strap through one End Piece (2), feeding it first through the inside of the slot furthest from the bolt hole, then back through the other slot as shown above. Fold the strap end flat. Proper strap length will result in the end pieces to be tightly joined in step 4.
3. Repeat Step 2 with the other end of the strap and the second End Piece.
4. Wrap the straps and end pieces around the pole. Insert the 1-3/4" hex bolt through the holes in the End Pieces. Join them with a plated washer and hex nut. Tighten until snug.
5. Repeat Steps 1-4 for the second assembly.
6. Insert one of the short (5/16" x 3/4") hex bolts through a nylon washer, through the sign's mounting hole, and then into the threaded hole in the Flared Leg Bracket. Tighten securely.
7. Repeat Step 6 for the second assembly.



**TAPCO**® ©2013, Traffic & Parking Control Company, Inc. (TAPCO) All Rights Reserved.  
Document: BRKT\_Flared\_guide\_130606 Reference 13061043  
www.tapconet.com 800-236-0112 262-814-7303

