

**CUBE RELAY, MULTIFUNCTION**



**MC363 Timers**

MC363 series are multifunction timers with dipswitch adjustments, relay output and LED indicator.

Offering five timing modes in a single unit and time delay settings from 0.1 second to 1023 minutes, the MC363 series is a cost-effective solution for myriad applications.

Provides timed sequencing of functions such as liquid dispensing, moisture purging, stirring, controlled lighting, feed distribution, water and air circulation, and many more.

**Timing Modes**

For all timing functions RED led indicates the output relay is on; green LED indicates the output relay is off.

**1 Delay on Make** Application of input voltage to the timer starts the time delay. At the end of the time delay the load is energized. To reset, remove the input voltage from the timer.

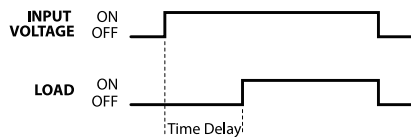

**2 Delay on Break** Input voltage is applied continuously. Upon closure of the initiate switch the load is energized and remains energized as long as the switch is closed. When the initiate switch opens, the load remains energized and the time delay is started. At the end of the time delay the load is de-energized and the timer is ready for another cycle.

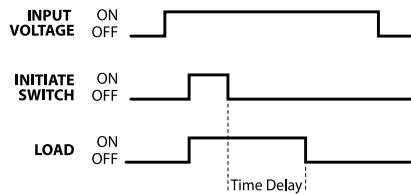

**3.1 Single Shot** Input voltage is applied continuously. Upon closure of the initiate switch the load is energized and the time delay is started. At the end of the time delay the load is de-energized and the timer is ready for another cycle. Maintained closure of the initiate switch will not affect the time delay period.

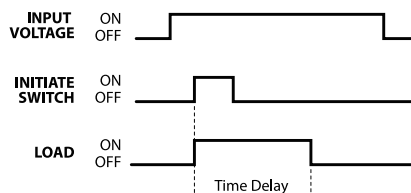

**3.2 Interval** Replace the initiate switch with a permanent electrical connection between terminals 1 and 2. Application of input voltage to the timer energizes the load and starts the time delay. At the end of the time delay the load is de-energized.

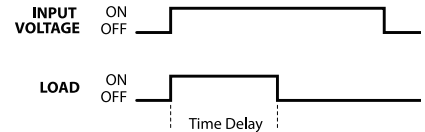

To reset, remove the input voltage from the timer.

**4 Resettable Single Shot / Watchdog** Input voltage is applied continuously. Upon closure of the initiate switch the load is energized and the time delay is started. Maintained closure of the initiate switch will not affect the time delay period. When the initiate switch is opened and re-closed while the load is energized the time delay is re-started. At the end of the time delay the load is de-energized and the timer is ready for another cycle.

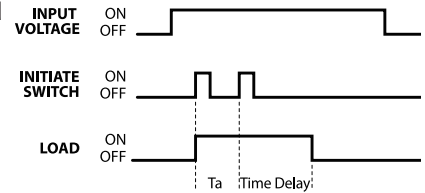

Note: Ta is less than Time Delay

**FEATURES**

- Multifunction, accurate timing
- Binary dipswitch adjustable
- Wide selection of timing ranges
- Wide selection of AC and DC input voltages
- Totally encapsulated for protection from harsh environments
- 100% operational testing
-  RoHS compliant

## BASIC WIRING AND DIMENSIONS

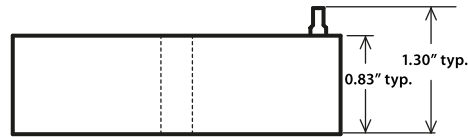
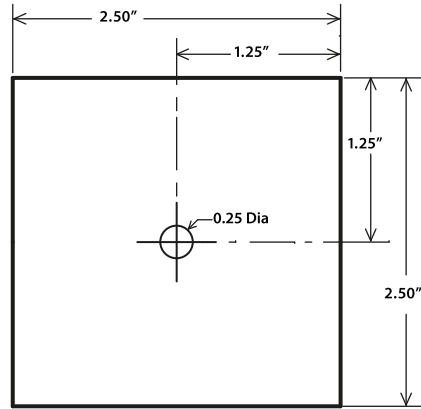
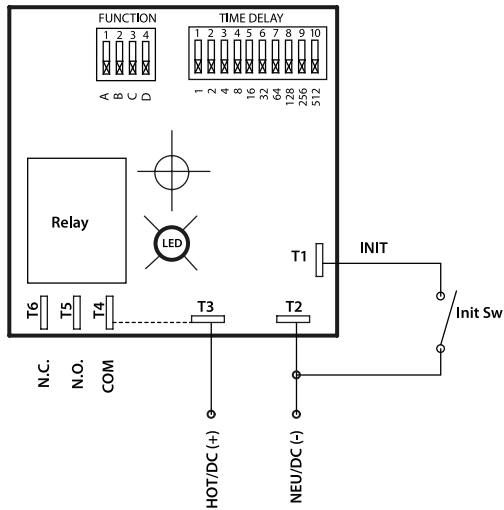

## SPECIFICATIONS

**Input Voltage:** 24, 120 or 230VAC, 50 / 60Hz,  $\pm 10\%$ ;  
12 or 24VDC  $\pm 10\%$

**Output current:** 10A resistive, max.

**Time delay:** Adjustable from 0.1 second to 1023 minutes,  
see *Timing Function Table*

**Timing function:** Multiple timing modes available  
see *Timing Function Table*

**Repeatability:** 0.1% or 20mS, whichever is greater

**Time delay accuracy:** 2.5% or 50mS, whichever is greater

**Recycle / Start-up time delay:** 250mS, typ.

**Temperature Ranges:** *Storage:* -40°C to +85°C  
*Operating:* -25°C to +60°C

**Mechanical:** 2.5" x 2.5" case, Surface mount with  
one #8 or #10 screw  
0.25" QC terminals for input and output

**Protection:** Encapsulated circuitry,  
MOV transient protection

## OPTIONS SELECTION

Mode of Operation	Series	Part Number	Input Voltage
Multi-function and Resettable	MC363	MC1003631H	120VAC
		MC2003631H	230VAC
		MC3003631H	24VAC
		MC7003631H	12VDC
		MC4003631H	24VDC

Configure settings via Function dipswitches

Dipswitch	Function	Dipswitch	Function
A	B	C	D
Timing Mode		Time Range	
0	0	0	0
0	1	0	1
1	0	1	0
1	1	1	1

Combine Time Delay dipswitches to achieve desired time delay