

# Hydra DI - Operation & Maintenance Manual

## High Capacity Deionization System



**For Model: HY-122B-DI-HC**

**TECHNICAL SPECIFICATIONS:**

|                                 |                         |
|---------------------------------|-------------------------|
| Pressure Range:                 | 10-100 psi              |
| Temperature Range:              | 40 - 100 °F             |
| Maximum Flowrate:               | 1.25 Gallons per minute |
| Resistivity Output              | 50 KOhm to 200 KOhm     |
| Resistivity DI Light Set Point: | 20 KOhm                 |
| Voltage                         | 120 VAC                 |

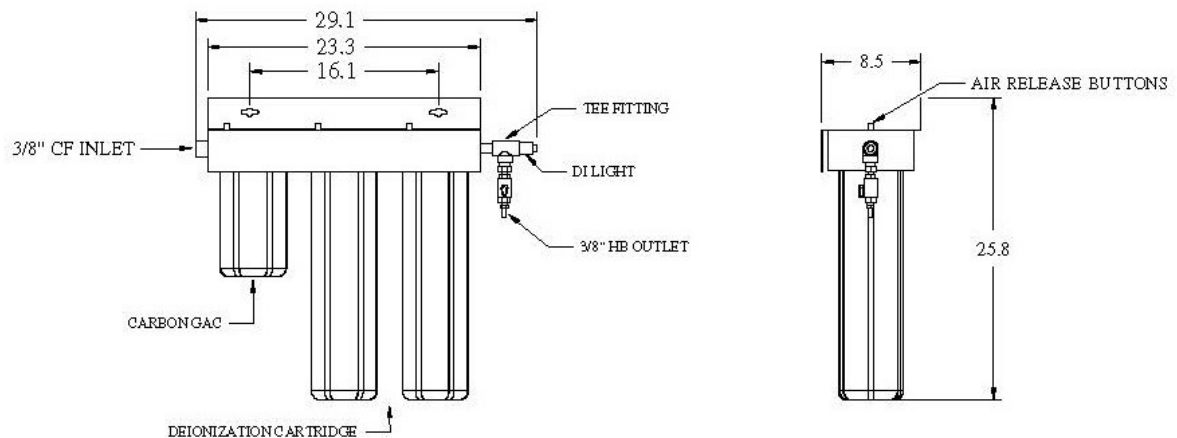
**SYSTEM DIMENSIONS****INSTALLATION**

1. Install system on a wall that will support 55 lbs, within 5 feet of a water supply.
2. Connection to water supply should include a shut off valve before the Hydra-DI system.
3. Use your choice of inlet fitting provided with the system to connect the tubing to the water supply valve. Attach the other end of the tubing to the OUTLET fitting of the DI system. NOTE: You may need to cut the tubing in 1/2.
4. Install quality monitor in horizontal end of gray tee fitting.
5. Install the outlet assembly to the vertical end of the tee. This fitting should have several wraps of white Teflon tape.

**START UP**

1. Before installing the deionization bed cartridges and carbon cartridge, make sure the sealing gaskets are in place.
2. Remove the blue housing bowls and place the 10" carbon cartridge in the 10" housing. Place the 20" deionization cartridges in the (2) 20" housings.
3. Fasten blue bowls back in place, HAND TIGHT.
4. Plug in the quality monitor. The light will be green.
5. Open the inlet water supply valve to allow water to enter the system.
6. Starting on the left, press each of the red pressure relief buttons at the top of the filter housing to expel trapped air. Release the button once water trickles out. Repeat for housings #2 and #3.
7. Open the system outlet valve and drain approximately 1 gallon of water.
8. At this point, the quality indicator monitor should have a green light indicating the system is ready for use.

9. If the quality indicator light is red, press the red pressure relief button to check that all the air has been purged from the system. Then open the outlet valve and let water run out until the indicator light turns green.

### **OPERATION**

1. Turn off the water feed supply when the system is not in use.
2. When the system is not active, the quality light may turn red. This is normal condition. As you draw water from the system, the light will turn green again.
3. If the light remains red in a flowing condition, this is an indication that the deionization cartridges are exhausted and need to be replaced.
4. NOTE: Feedwater mineral content (total dissolved solids) and chemistry have a direct impact on the life of the cartridge. For TDS above 500 ppm, please contact Aries Filterworks for additional pretreatment options.

### **CARTRIDGE REPLACEMENT**

1. Turn off the inlet water feed supply.
2. Depressurize the system by pushing the red pressure relief button on the top of the filter housing
3. Place a container under the filter housing to collect and excess water.
4. Unscrew the filter bowl housing. The included spanner wrench may be needed.
5. Remove the old cartridges and discard
6. Inspect the o-rings and add lubrication if needed.
7. Install the cartridges per the START UP procedure

### **REPLACEMENT PARTS**

HYK-010 Cartridge Kit, Hydra High Purity Deionization System (4-1/2" Diameter)  
Includes 10-inch Carbon Prefilter & (2) 20-inch High Capacity DI cartridges

### **TROUBLESHOOTING**

| <i>Problem</i> | <i>Cause</i>                   | <i>Solution</i>  |
|----------------|--------------------------------|--|
| DI light Red   | No Flow                        | During a non-flow condition, the DI light may turn from green to red. Verify that flow is going across the DI light sensor.  |
|                | Air Trapped                    | Make sure sensor is installed in horizontal run of Tee fitting. Ensure system has been properly vented per instructions.   |
|                | Exhausted Cartridges           | Replace cartridges as described in earlier section.  |
|                | High flowrate                  | Reduce the flowrate to the specified range. Higher flowrates will diminish the performance of the deionization resins.   |
|                | Cartridge improperly installed | Make sure all old cartridge gaskets are removed. The primary sealing surface is on the top gasket. Improper installation will cause bypass and compromise water quality. |

|                      |                   |   |
|----------------------|-------------------|---|
| Short Cartridge Life | High mineral feed | Check feedwater supply to determine total dissolved solids (TDS) level. Elevated levels due to changes in supply or seasonal changes may reduce cartridge life. Contact Aries Filterworks for other pretreatment options. |
|----------------------|-------------------|---|

**CUSTOMER SERVICE**

Aries Filterworks technical and customer service are available 9:00 AM to 5:00 PM EST.

Phone: 856-768-9600

E-mail: aries@resintech.com

**WARRANTY**

Systems and options have a one-year limited warranty from the date of purchase. If determined that a failure was due to defects in materials or workmanship, a repair or replacement will be made without charge. Aries Filterworks / ResinTech, Inc. assume no other responsibility or liability.

This warranty does not cover any product which has been subject to misuse, neglect, accident or used in violation of operating instructions nor does it extend to any units altered or repaired for warranty defects by anyone other than Aries Filterworks.

IN NO EVENT SHALL ARIES / RESINTECH, INC. BE LIABLE FOR ANY INCIDENTAL, CONSEQUENTIAL, SPECIAL, INDIRECT, PUNITIVE OR EXEMPLARY DAMAGES OR LOST PROFITS FROM ANY BREACH OF THIS WARRANTY OR OTHERWISE.

Aries Filterworks / ResinTech, Inc., reserves the right to make changes in design, specifications and prices without notice.