

CUSTOMER SPECIFICATION DRAWING

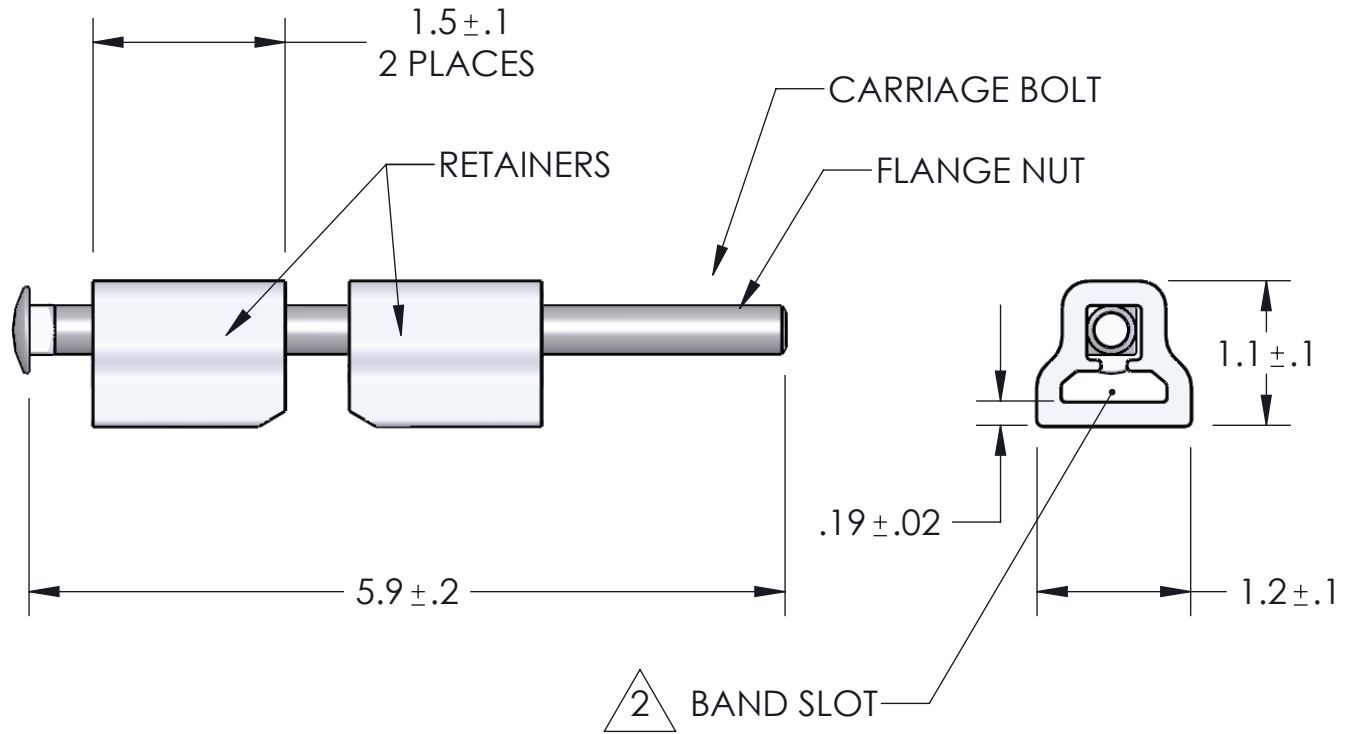

NOTES:

1. MATERIAL:
RETAINERS.....ALUMINUM ALLOY
CARRIAGE BOLT.....COATED STEEL
FLANGE NUT.....GALVANIZED STEEL

2. SLOT MUST ACCEPT DOUBLE WRAP
.045" X .75" (1.1mm X 19mm) BAND-IT BAND.

3. PACKAGED 10 PER BOX.
4. WEIGHT: 4.11 LBS

BAND-IT®

A unit of ~~IDEX~~ Corporation
P.O. Box 16307
Denver, Colorado U.S.A.

PROPRIETARY AND CONFIDENTIAL

THIS DRAWING WITH ALL CONTENTS IS
PROPERTY OF BAND-IT-IDEX, INC.
REPRODUCTION, DISCLOSURE OR MFG.
OF MATTER SHOWN IS PROHIBITED
WITHOUT WRITTEN PERMISSION.
DO NOT SCALE DRAWING.
UNLESS OTHERWISE NOTED, DIMENSIONS
ARE IN INCHES AFTER FINISH.

TITLE:

**BOLTED BAND
RETAINER, 3/4"**

DWG. NO.

GRD500

REV B