

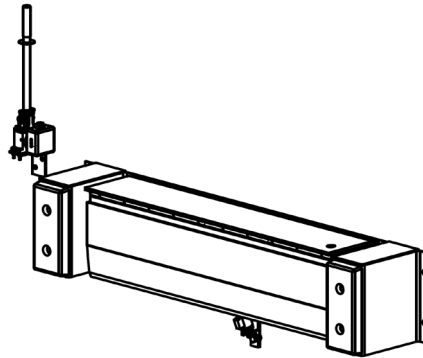

**Vestil Manufacturing Corp.**  
 2999 North Wayne Street, P.O. Box 507, Angola, IN 46703  
 Telephone: (260) 665-7586 -or- Toll Free (800) 348-0868

## PP-Series Dock Levelers Instruction Manual



### Receiving Instructions

After delivery, remove the packaging from the product. Inspect the product closely to determine whether it sustained damage during transport. If damage is discovered, record a complete description of it on the bill of lading. If the product is undamaged, discard the packaging.

**NOTE:** The end-user is solely responsible for confirming that product design, use, and maintenance comply with laws, regulations, codes, and mandatory standards applied where the product is used.

### Technical Service & Replacement Parts

For answers to questions not addressed in these instructions and to order replacement parts, labels, and accessories, call our Technical Service and Parts Department at (260) 665-7586. The Department can also be contacted online at <https://www.vestil.com/page-parts-request.php>.

### Electronic Copies of Instruction Manuals



Additional copies of this instruction manual may be downloaded from <https://www.vestil.com/page-manuals.php>.

### TABLE OF CONTENTS

	<b>PAGE</b>
Signal Words.....	2
Safety Instructions.....	2
National Standards.....	3
Exploded View & Bill of Materials.....	3
Hand Pump Exploded View & Bill of Materials.....	4
Specifications.....	5
Recommended Installation Site Characteristics.....	5
Installation Requirements for Docks without 6" Steel Edge.....	6
Approach Ramp Installation for Loading Docks Lower than 50".....	6
Installing the Dock Leveler.....	6 - 10
Method 1: Loading Dock with at Least 6" Wide Steel Edge.....	7
Method 2: Loading Dock with Steel Edge less than 6" Wide.....	7 - 8
Method 3: Loading Dock without Steel Edge.....	9 - 10
Completing the Installation.....	10 - 11
Manual Hydraulic Pump.....	11 - 12
Operation.....	12
Air Purging Procedure.....	12
Troubleshooting.....	12
Record of Satisfactory Condition.....	13
Inspections and Maintenance.....	13 - 14
Labeling Diagram.....	14
Limited Warranty.....	15

## SIGNAL WORDS

SIGNAL WORDS appear in this manual to draw the reader's attention to important safety-related messages. The following are signal words used in this manual and their definitions.

 <b>DANGER</b>	Identifies a hazardous situation which, if not avoided, <b>WILL</b> result in <b>DEATH</b> or <b>SERIOUS INJURY</b> . Use of this signal word is limited to the most extreme situations.
 <b>WARNING</b>	Identifies a hazardous situation which, if not avoided, <b>COULD</b> result in <b>DEATH</b> or <b>SERIOUS INJURY</b> .
 <b>CAUTION</b>	Indicates a hazardous situation which, if not avoided, <b>COULD</b> result in <b>MINOR</b> or <b>MODERATE</b> injury.
<b>NOTICE</b>	Identifies practices likely to result in product/property damage, such as operation that might damage the product.

## SAFETY INSTRUCTIONS

Vestil strives to identify foreseeable hazards associated with the use of its products. However, material handling is dangerous and no manual can address every conceivable risk.

### **WARNING**

If this product is installed, used, or maintained improperly serious personal injuries or death might result.

- **Read and understand the entire manual before installing, using, or servicing the product.** Keep this manual in a location known to persons who use the dock leveler. Read the manual whenever necessary to refresh your understanding of proper use, inspection, and maintenance procedures.
- The manual should be stored in a location known to all persons who use the dock leveler. It should be available to anyone needing refresh the understanding of proper use and maintenance procedures.
- The Edge-O-Dock Leveler presents falling, pinch point, and impact hazards to the user and bystanders. ALWAYS follow these instructions to avoid injury.
- DO weld the dock leveler securely to the dock face before use. DO anchor the dock leveler to the dock if necessary. See [INSTALLING THE DOCK LEVELER](#) starting on [page 6](#).
- DO NOT install the dock leveler on a dock that is not flat and level.
- DO inspect the product according to the instructions on [p. 13](#) & [14](#). Replace each part that is not in [SATISFACTORY CONDITION](#). See [RECORD OF SATISFACTORY CONDITION](#) on [p.13](#). ONLY use manufacturer approved replacement parts. DO NOT use the leveler until it is fully restored to satisfactory condition.
- DO NOT use a dock leveler that has not been welded continuously across its top edge to the dock face. DO NOT use a dock leveler if any welds are cracked.
- DO NOT use a dock leveler that rocks or shifts when a load is placed on it. Remove it from service.
- DO wear appropriate PPE, at least footwear compliant with ASTM F2413 (formerly ANSI Z41-1999) and eye guards compliant with ANSI Z87.1-2010.
- DO NOT use the dock leveler if you tire quickly or easily, or if you have experienced fainting spells. DO NOT use the dock leveler if you are under the influence of alcohol, medication, or other substances that affect your balance or coordination. Only use the dock leveler if you are in good physical health.
- DO NOT use a handle other than the factory-supplied handle to operate the hand pump.
- DO maintain solid footing while operating the dock leveler.
- DO NOT attempt to extend the dock leveler if no trailer is present in the dock.
- DO NOT extend the dock leveler while people in the truck bay are within reach of the unit.
- DO NOT store items on the dock leveler. DO NOT attempt to use the dock leveler if objects are on top of it. ALWAYS check the dock leveler for foreign objects before use. Only use this item as intended.
- DO NOT exceed the capacity for the dock leveler. The capacity is provided on the nameplate label which is applied to the right-hand side of the deck weldment. See [LABELING DIAGRAM](#) on [p. 14](#).
- DO NOT force the lip plate to extend using your hands or other mechanical means. Remove it from service until it is restored to [SATISFACTORY CONDITION](#).
- DO NOT use this device UNLESS every label is in place, undamaged, and easily readable from a reasonable distance. See [LABELING DIAGRAM](#) on [p. 14](#).
- DO NOT modify the dock leveler in any way.
- DO NOT modify the product in any way. Modifications might make the lifter unsafe to use and automatically void the [LIMITED WARRANTY](#). See [p. 15](#).
- DO NOT use the dock leveler unless all machine guards are in place.
- DO NOT operate the leveler while anyone is standing on it or within range of the bridge plate when it is extended.
- DO NOT change the setting of the pressure relief valve.

## NATIONAL STANDARDS

PP-series products are dock leveling devices. American National Standard ANSI MH30.1 (the "Standard") provides operation, inspection, and maintenance instructions for owners of dock leveling devices. A copy of the Standard can be purchased online at <https://webstore.ansi.org/Standards/MHIA/ANSIMH302015>. Acquire a copy of the Standard and apply all relevant operation, inspection, and maintenance instructions. Contact local occupational safety and health specialists to determine whether there are laws, ordinances, codes, etc. ("authorities") in addition to the Standard that apply to dock leveling devices in the location where the device will be used. If content in this manual conflicts with provisions in authorities or the Standard, apply the provisions from the authorities or Standard. Please contact the [TECHNICAL SERVICE](#) department to report conflicts as soon as they are discovered.

## EXPLODED VIEW AND BILL OF MATERIALS

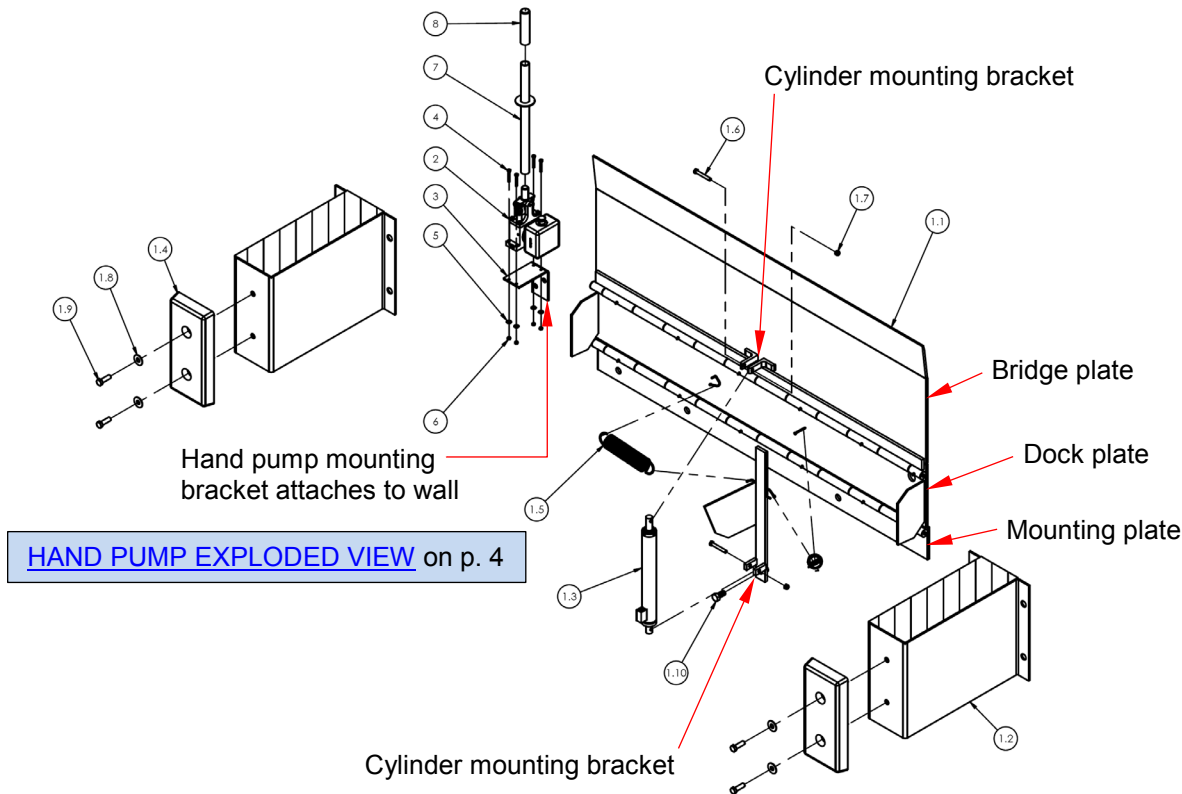

Item	Part no.	Description	Qty.	Item	Part no.	Description	Qty.
1.1	06-513-197 06-513-002 06-513-001 06-513-006 06-513-005 06-513-201 06-513-004 06-513-003	WELDMENT, DECK ASSEMBLY	1	1.4	29-001-001	SPECIALTY MOLDED RUBBER BUMPER	2
		PP-1572-36		1.5	15-146-001	SPRING, EXTENSION, W/FULL LOOP, 13.57#/IN	2
		PP-2066		1.6	17165	HEX CAP SCREW, GRADE 5, ZINC FINISH, 7/16"-20 x 3"	2
		PP-2072		1.7	37127	NYLON LOCK NUT, GRADE 2, ZINC FINISH, 7/16"-20	2
		PP-2566		1.8	33016	FLAT WASHER, LOW CARBON, USS, ZINC PLATED, 5/8"	4
		PP-2572		1.9	11311	HEX BOLT, GRADE 2, ZINC FINISH, 5/8"-11 x 2"	4
		PP-2572-36		1.10	13359	HHCS #5 Z PLATED, 3/4 - 10 x 1 1/2	1
		PP-3066		2	99-640-012	ASSEMBLY, HAND PUMP, 1/4 GAL. TANK (EXPLODED VIEW ON P. 4)	1
		PP-3072		3	06-016-009	BRACKET, PUMP MOUNT, FORMED	1
1.2	06-514-014 06-514-015	WELDMENT, BUMPER BOX	2	4	11011	HEX BOLT, GRADE A, ZINC PLATED, 1/4"-20 X 2"	4
		Deep: PP-1572-36; PP-2572-36		5	33004	FLAT WASHER, USS, ZINC PLATED, Ø1/4"	4
		15": PP-2066; PP-2072; PP-2566; PP-2572; PP-3066; PP-3072		6	37018	NYLON LOCK NUT, GRADE 2, ZINC FINISH, 1/4"-20	4
1.3	99-021-931-001 99-021-940	CYLINDER, HYDRAULIC, RAM STYLE	1	7	07-525-006	ASSEMBLY, HANDLE	1
		1" x 14": PE-2066; PE-2072		8	07-025-005	HANDLE, BLACK RUBBER, 6"	1
		1 1/2" x 14": PE-1572-36; PE-2566; PE-2572; PE-2572-36; PE-3066; PE-3072					

# HAND PUMP EXPLODED VIEW AND BILL OF MATERIALS (99-640-012)

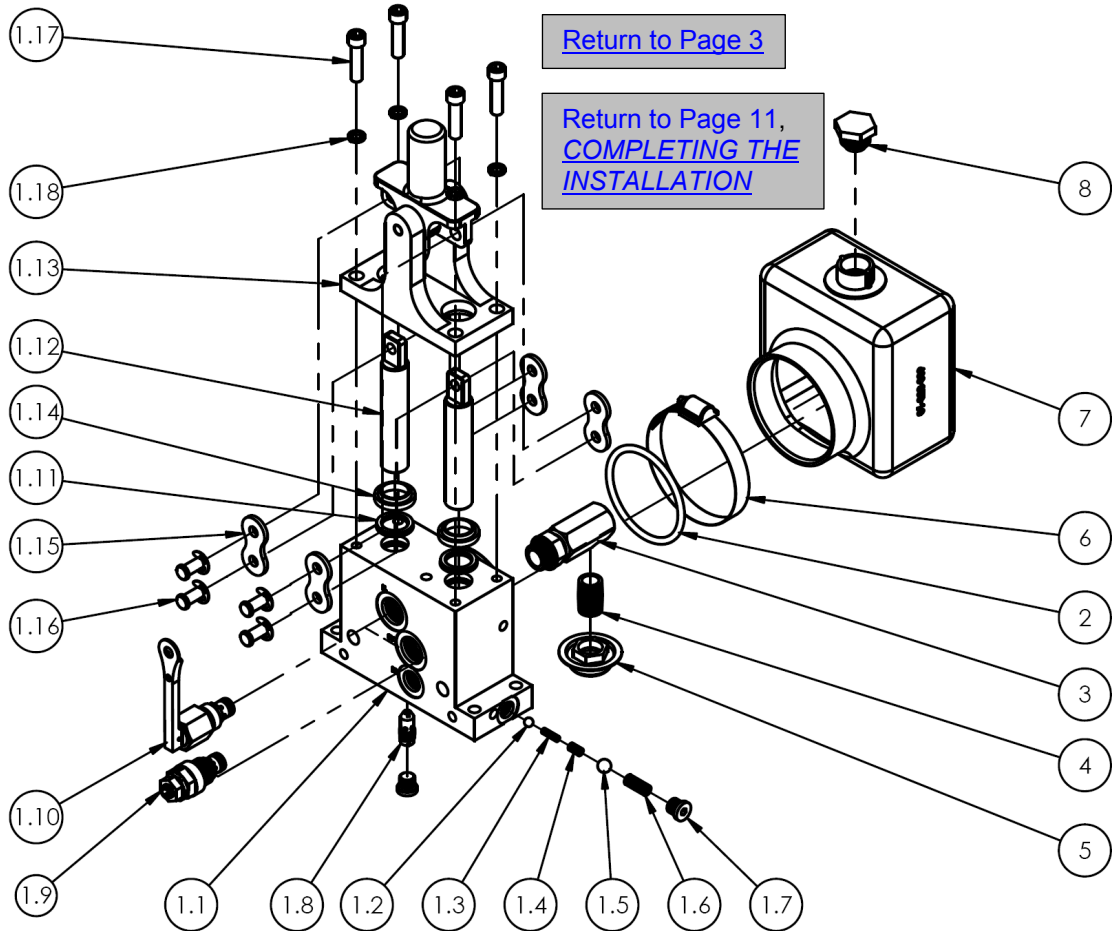

Item	Part no.	Description	Qty.
1	99-140-005	SUB-ASSEMBLY, MANUAL PUMP, HAND	1
1.1	99-039-005	BODY, MANUAL PUMP, HAND	1
1.2	99-110-007	BEARING, BALL, Ø1/4"	2
1.3	99-146-004	SPRING, COMPRESSION, INLET CHECK	2
1.4	99-146-006	SPRING, COMPRESSION, RETAINER	2
1.5	99-110-006	BEARING, BALL, Ø3/8"	2
1.6	99-146-005	SPRING, COMPRESSION, OUTLET CHECK	2
1.7	99-116-005	FITTING, HYDRAULIC, 04MORB HOLLOW HEX PLUG	3
1.8	99-153-038	FLOW CONTROL, PRES. COMP., 1.0 GAL.	1
1.9	99-153-006	VALVE, PRESSURE RELIEF, 210 BAR	1
1.10	99-153-080	VALVE, RELEASE, CARTRIDGE w/TOGGLE ARM	1
1.11	99-144-015	SEAL, U-CUP	2
1.12	99-041-004	PLUNGER/PISTON, PUMP	2
1.13	99-640-008	SUB-ASSEMBLY, PUMP, ROCKER	1
1.14	99-144-003	WIPER, SOLID PROFILE, PISTON	2
1.15	99-042-001	CHAIN, SIDE PLATE, #80	4
1.16	11484-01103	PIN, SS GROOVED CLEVIS w/ SNAP RING	4
1.17	93257	SHCS 5/16-18 x 1 1/4	4
1.18	129169	LOCK WASHER, HI COLLAR, ZINC PLATED	4
2	99-144-007	O-RING, MANIFOLD, 3" OD	1
3	99-116-001	SUCTION FITTING, MINI MANIFOLD	1
4	99-031-033	ACCESSORIES, NIPPLE, CLOSE PIPE	1
5	99-031-029	SCREEN, INLET, 1.75" DIAMETER	1
6	99-145-061	CLAMP, WORM GEAR HOSE, 2 13/16 - 3 3/4	1
7	01-023-009	RESERVOIR, OIL	1
8	99-616-001	ASSEMBLY, BREATHER	1

# SPECIFICATIONS

Documents that provide specifications for PP-series dock levelers are available online to anyone who visits Vestil's website. Specifications include dimensions, net weight, and capacity information. To access the appropriate specifications document, navigate to this webpage: <https://www.vestil.com/product.php?FID=5>. Click the *Product Specifications Table* tab. Scroll the page to the entry for the model you purchased, and click the button in the *PDF* column that looks like a pencil inside a blue box. A PDF file will open. This file is the specifications document for your dock leveler. Print a copy of the document and keep it with your copy of this manual.

The following is an exemplar specifications document for model PP-1572-36.

**EDGE-O-DOCKLEVELER - PP-1572-36**

APPROX WEIGHT: 662.26 lbs.  
DOES NOT INCLUDE WEIGHT OF POWER OR PACKAGING

\*\*\* ANY ADDITIONS, DELETIONS, OR OMISSIONS MUST BE CORRECTED ON THIS DRAWING AS THIS DRAWING WILL BE CONSIDERED ALL INCLUSIVE \*\*\*  
 ALL GRAPHICS PROVIDED ARE FOR REFERENCE ONLY. IF CERTAIN DIMENSIONS ARE CRITICAL PLEASE VERIFY THOSE DIMENSIONS WITH YOUR SALESPERSON

\*\*HAND PUMP NOT SHOWN IN FRONT OR RIGHT VIEW\*\*

**STANDARD FEATURES**  
 MODEL NUMBER IS PP-1572-36  
 OVERALL WIDTH IS 98"  
 DECK WIDTH IS 72"  
 OVERALL DEPTH WITH RAMP OUT IS 36 5/8"  
 BUMPER PROJECTION IS 26 3/4"  
 UNIFORM CAPACITY IS 15,000 LBS.  
 5" ABOVE / 5" BELOW SERVICE RANGE  
 RECOMMENDED FOR DOCKS AT LEAST 48" HIGH  
 HYDRAULIC HAND PUMP OPERATION  
 INCLUDES HAND PUMP, WALL-MOUNT BRACKET,  
 CYLINDER, HYDRAULIC LINES AND OIL  
 TREADPLATE RAMP & DECK CONSTRUCTION

**SPECIAL FEATURES**  
 NONE

**APPROVAL**

I, THE UNDERSIGNED, AGREE THAT THE PRODUCT AS REPRESENTED SATISFIES DESIGN AND DIMENSION REQUIREMENTS. I ALSO ACKNOWLEDGE MY DUTY TO CONFIRM PRODUCT AND INSTALLATION COMPLIANCE WITH ALL APPLICABLE FEDERAL, STATE AND LOCAL REGULATIONS AND STANDARDS.  
**UNITS REQUIRING APPROVAL DRAWINGS OR MODIFIED ARE NON-RETURNABLE**  
 As drawn  As marked

Signed: \_\_\_\_\_ Date: \_\_\_\_\_  
 Printed Name: \_\_\_\_\_  
 LEAD TIME WILL START UPON RECEIPT OF SIGNED APPROVAL DRAWING

FOR INTERNAL USE ONLY PROJECT SIGN OFF	VESTIL MANUFACTURING	DATE: _____	SCALE: 1:20
SALES _____	DRAWN BY: _____	SALES: _____	SEE NAME: _____
ENG. _____	REFERENCE: X	SALES: X	DATE: _____
FAB. _____	QUOTED LEAD TIME: X	QUOTE # X	06-007-061
POWER _____			

# RECOMMENDED INSTALLATION SITE CHARACTERISTICS

The optimal installation site is a loading dock where the floor is 50 inches above the ground. If the dock is lower than 50 inches, ramps and ramp support angles are necessary. The dock face should include 6 inch, integral steel channel along the top edge of the loading dock floor. This feature allows the dock leveler and dock bumpers to be welded directly to the steel channel. Concrete anchors must be at least 1 1/2 inches wide by 6 inches long with a 1 1/2 inch perpendicular segment at both ends. Anchors must be made from at least 1/4" steel and should be welded to the channel in 12 inch increments. Optimal (recommended) dock edge construction is shown in the diagrams.

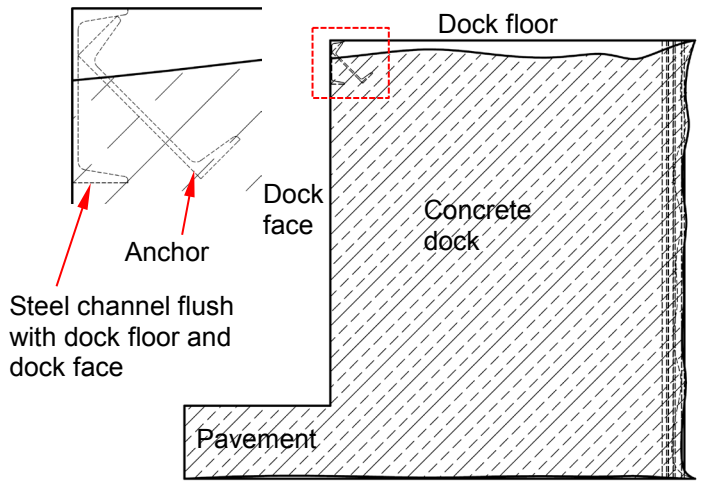
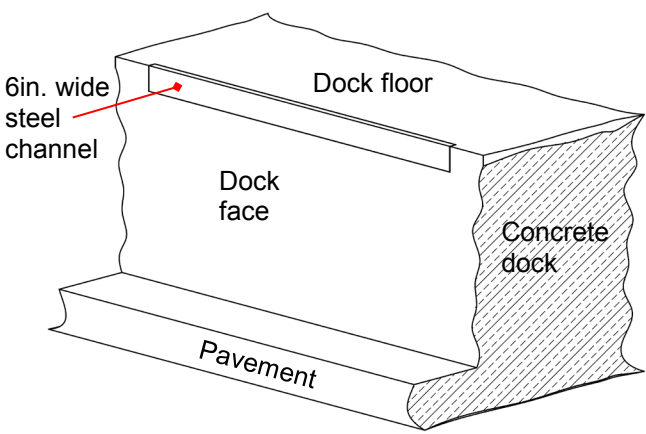
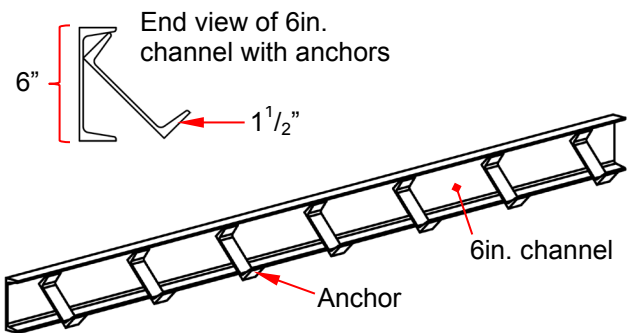



**Installation requirements for loading docks without 6in. steel edge:**

If your loading dock lacks 6 inch steel edging, then either: 1) the edging is less than 6 inches wide; or 2) there is no steel edge.

1) If the installation site includes integral steel channel along the dock edge, but the channel is less than 6 inches wide, the dock leveler must be both welded and fastened to the dock face with anchor bolts. This installation is described in [Method 2](#) on pages 9-10.

2) A steel approach plate must first be anchored to the floor if the dock has no steel edging. The dock leveler is then welded to the front edge of the approach plate. This installation is described in [Method 3](#) on pages 11-12.

**Approach ramp installation for loading docks lower than 50 inches (dock floor less than 48 inches above pavement):**

If the dock floor is less than 50 inches above the pavement, then a ramp might be necessary. The dock leveler is installed to be 50 inches above the pavement and a ramp provides a smooth transition from the dock floor to the top of the leveler. The diagrams provide an example of a dock floor 48 inches above the pavement.

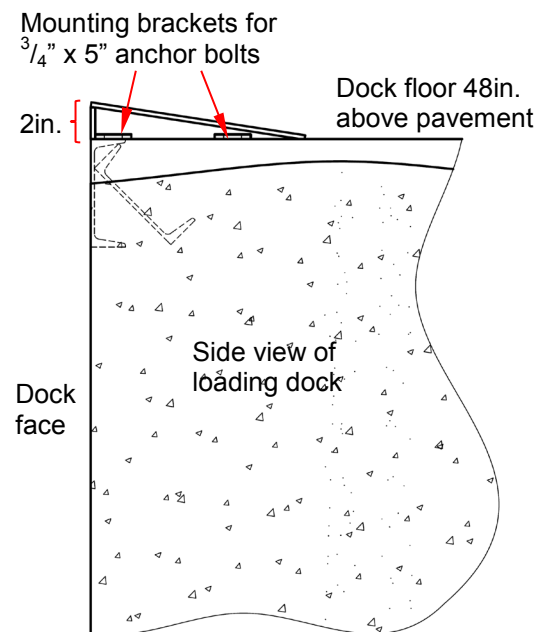
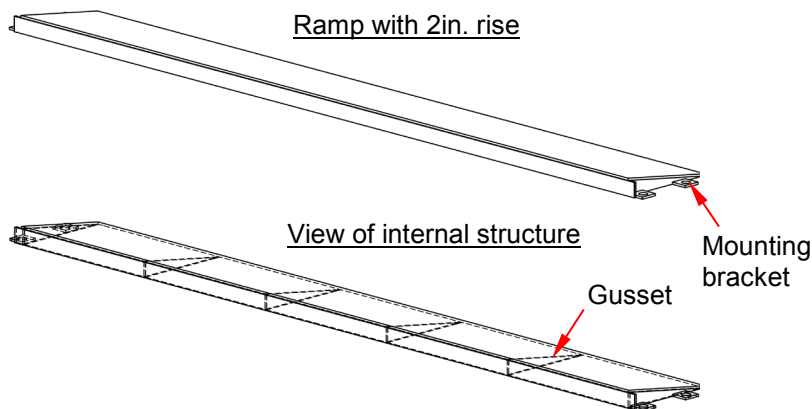
**INSTALLING THE DOCK LEVELER**

**WARNING** Improperly installing the dock leveler decreases its capacity and might make it unsafe to use. If the dock face does not include integral steel channel, then an approach plate must be installed.

Three methods of installing the dock leveler are provided in this manual. The methods are presented in order of preference, i.e. the unit should be installed according to Method 1, which requires an integral steel edge at least 6 inches wide. If the loading dock has a steel edge that is less than 6 inches wide, then use [Method 2](#). If the dock does not have a steel edge at all, then use [Method 3](#). For all 3 methods, begin the installation with steps A-D by cleaning and preparing the site and moving the dock leveler into position.

- A. Clean the installation site and the steel edge. The edge must be free of protrusions. Remove burrs, etc. from the edge surface. The floor surface and front face of the dock should be smooth.
- B. Measure the width of the dock door (double-ended arrow). Find and mark the center of the door opening (dashed line).
- C. Move the leveler to the installation site, e.g. with a forklift boom. In the diagram, a forklift boom is shown attached to the bridge plate.
- D. Center the dock leveler on the center of the dock doorway.

Proceed to the instructions for:

- i. [Method 1](#) if the dock has a 6in. (or wider) steel edge; OR
- ii. [Method 2](#) if the dock has steel edge less than 6in. wide; OR
- iii. [Method 3](#) if the dock does not have a steel edge.

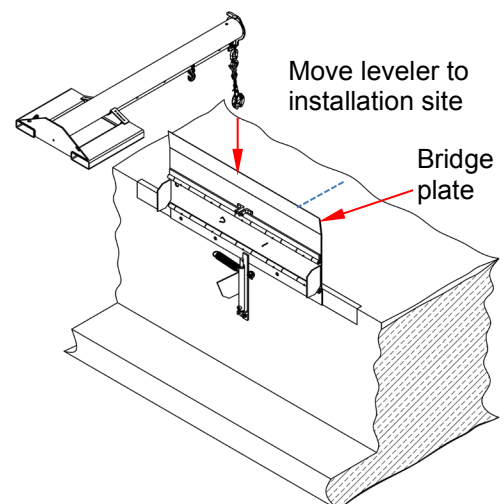
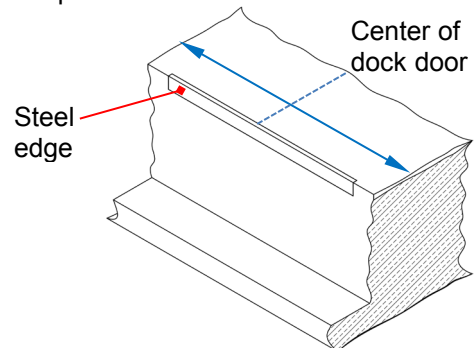
**Prepare installation site**

**METHOD 1: Loading dock with at least 6in. wide steel edge**

- E. The top of the dock leveler mounting plate should be flush with the top of the steel edge. Tack weld the mounting plate to the edge at both ends.
- F. Continuously weld the top edge of the mounting plate to the steel edge.
- G. Install dock bumpers on both sides of the leveler.
  - i. Align the top of each bumper with the top of the steel edge/dock floor.
  - ii. Tack weld the bumpers to the steel edge.
  - iii. Continuously weld the top and both sides of both bumpers to the steel edge.

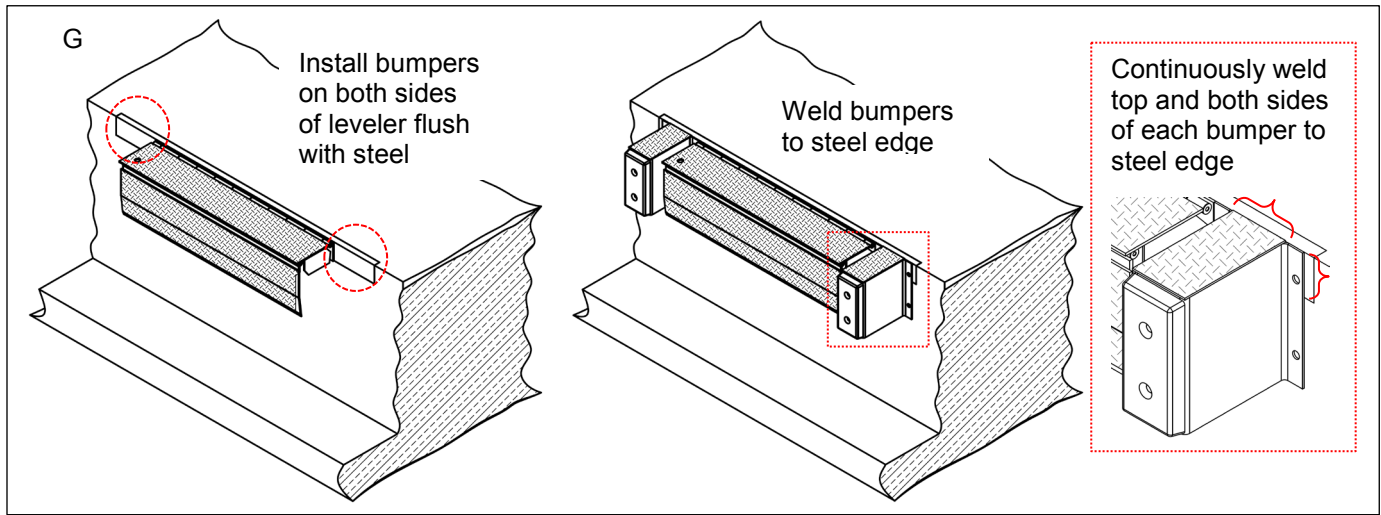
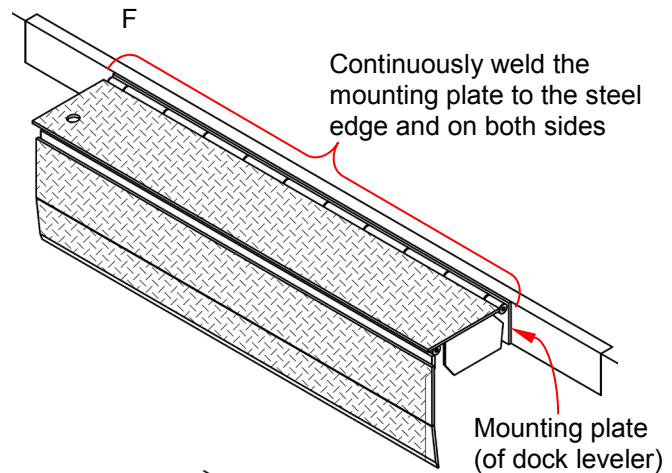
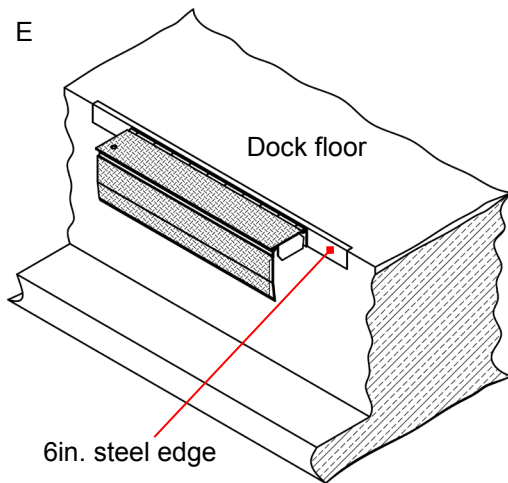
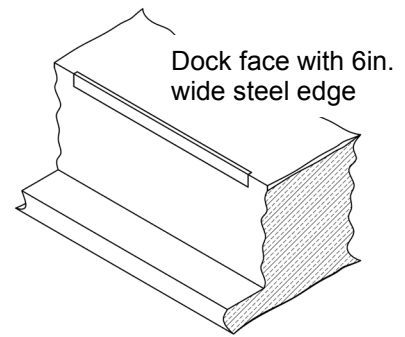

**METHOD 2: Loading dock with steel edge less than 6in. wide**

- E. The top of the dock leveler mounting plate should be flush with the top of the steel edge. Tack weld the mounting plate to the edge at both ends.
- F. Continuously weld the mounting plate to the steel edge.
- G. Install four (4) 3/4" x 5" lag bolts to fasten the (dock leveler) mounting plate to the dock face.
- H. Install dock bumpers on both sides of the leveler.
  - i. Align the top of each bumper with the dock floor.
  - ii. Tack weld the bumpers to the steel edge.
  - iii. Continuously weld the tops of both bumpers.
  - iv. Continuously weld the sides of each bumper.
  - v. Install a 3/4" x 5" lag bolt through the outside and inside flanges of both bumpers.

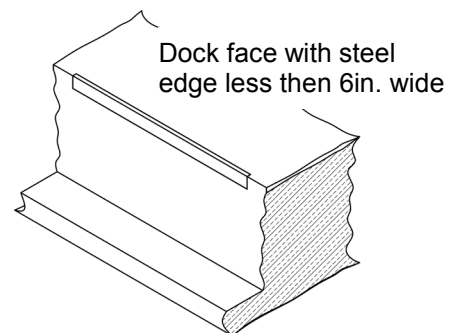

[Additional diagrams on following page](#)

**METHOD 2 (continued): Loading dock with steel edge less than 6in. wide**

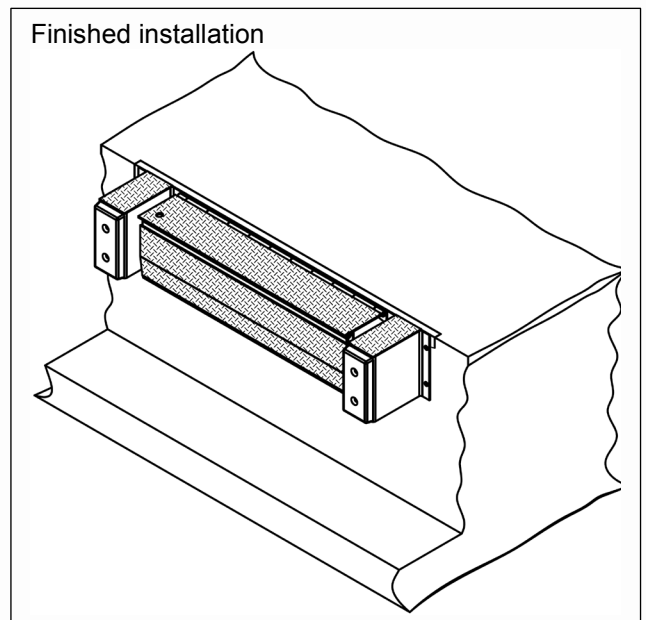
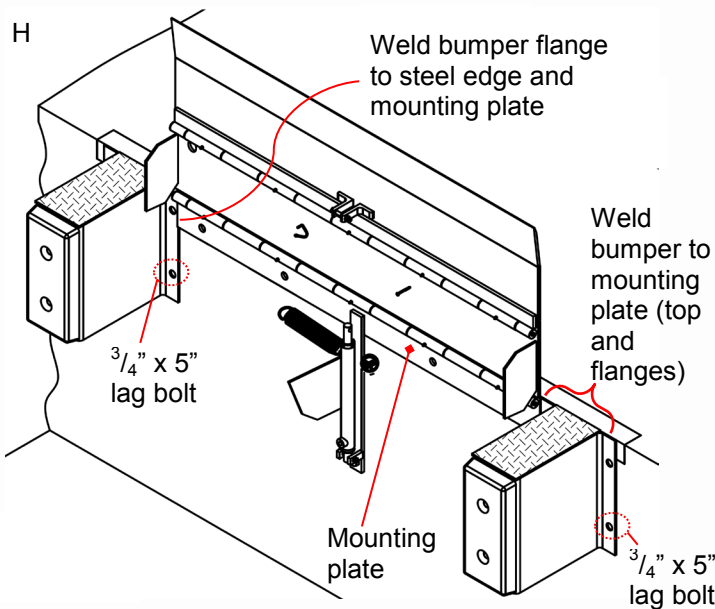
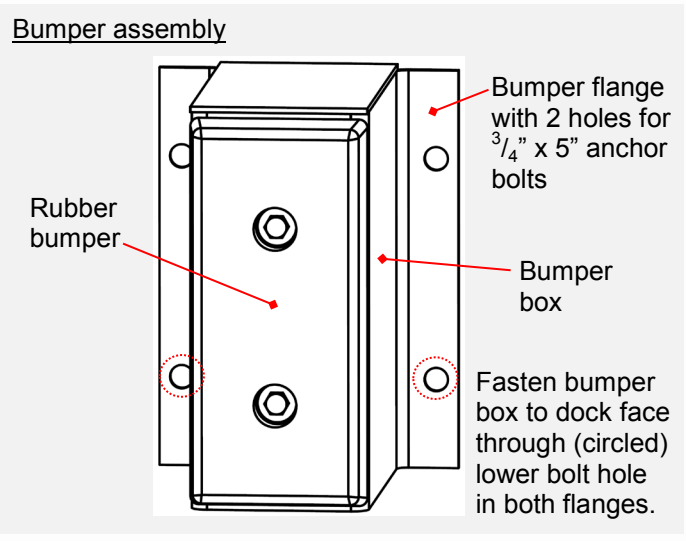
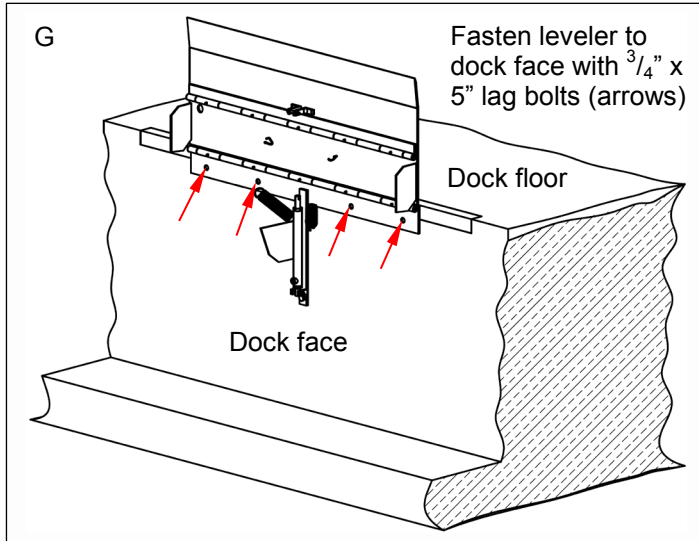
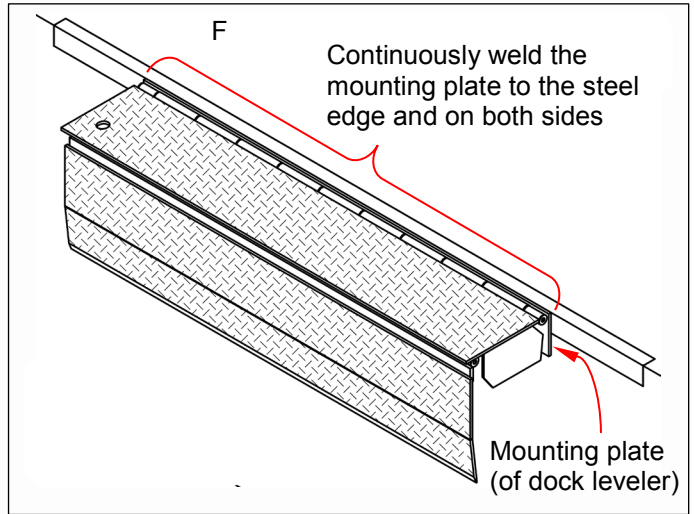
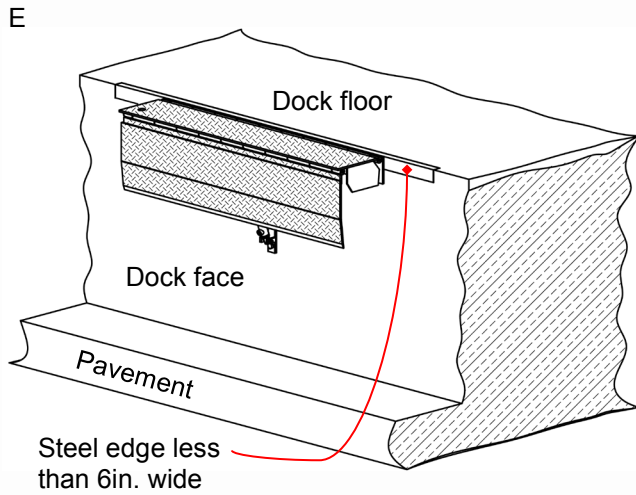



**METHOD 3: Loading dock without steel edge**

- E. Make sure that the dock floor and dock face are smooth. Grind/sand surface features on the concrete along the dock edge. Sand a 6in. region 4.5ft. on each side of the center of the dock door. The areas to sand on the dock floor and dock face are cross-hatched.
- F. Your installation might require an approach plate to provide a smooth transition from the dock floor to the dock leveler. For example, loading docks where palletized goods are slid across the floor and into a trailer, an approach plate is necessary. If your installation requires an approach plate, the lip of the plate must be recessed in a groove in the dock floor. Measure the length of the plate. Find the center of the door opening and mark the floor. Mark the floor the length of the approach plate plus ~1in. parallel to the dock edge 12 inches from the face of the dock. Cut a  $\frac{3}{8}$ in. deep x 2in. wide groove along the mark. [NOTE: The inside edge of the groove will be 10in. from the dock edge.]
- G. One edge of the approach plate is formed with a slight downward bend. Set this edge of the plate in the groove. Adjust plate position so that the opposite edge is flush with the dock face. Then, anchor the plate to the floor with six (6)  $\frac{3}{4}$ in. x 5in. lag bolts. Do not tighten the bolts at this time.
- H. Tack-weld the mounting plate of the leveler to the approach plate at both ends. The tops of the mounting plate and approach plate should be flush and level. Continuously weld the mounting plate to the edge of the approach plate.
- I. The mounting plate includes 4 bolt holes. Drill holes into the dock face at all 4 locations for  $\frac{3}{4}$ in. x 5in. anchor bolts. Install the bolts but do not tighten them completely at this time.
- J. Install a dock bumper on each side of the leveler. Begin by welding the top edge of each bumper box to the edge of the approach plate. Then, drill 4 holes (2 in each flange; see [BUMPER ASSEMBLY](#) on p. 8) for  $\frac{3}{4}$ in. x 5in. anchor bolts. Install the bolts and  $\frac{3}{4}$ in. flat washers.
- K. Tighten the bolts installed through the mounting plate (4) and bumpers (4 each; 8 in total). Then, tighten the bolts in the approach plate (6 in total). Weld the bolts in the approach plate to the plate; then grind and round them off.

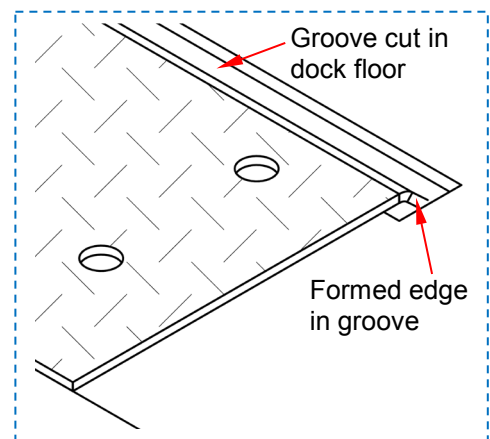
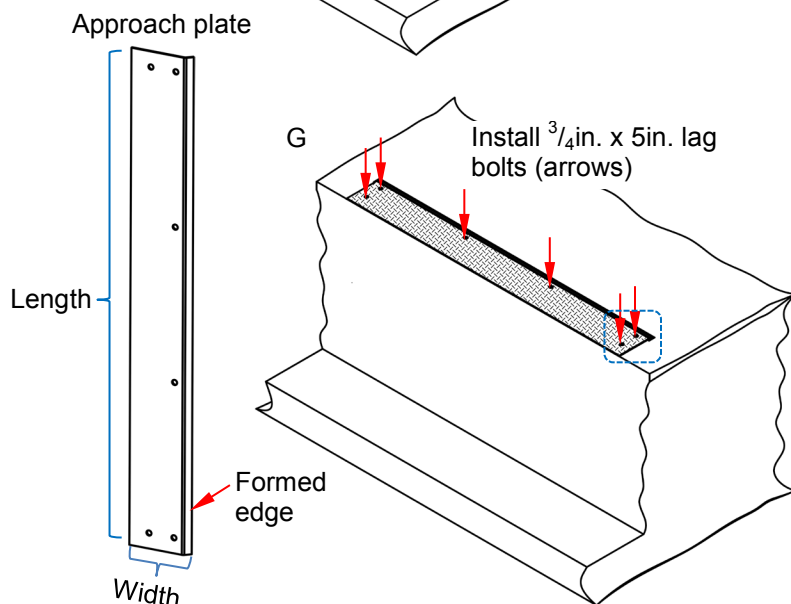
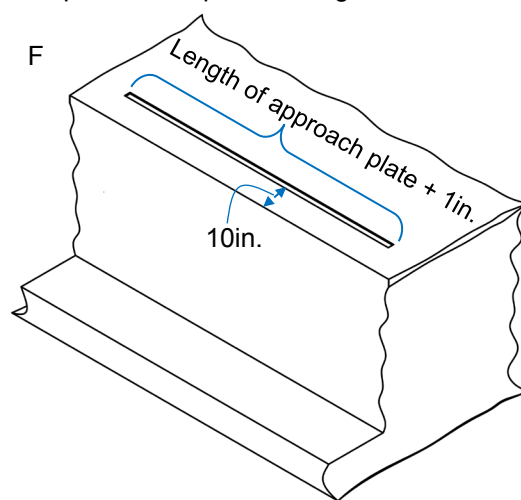
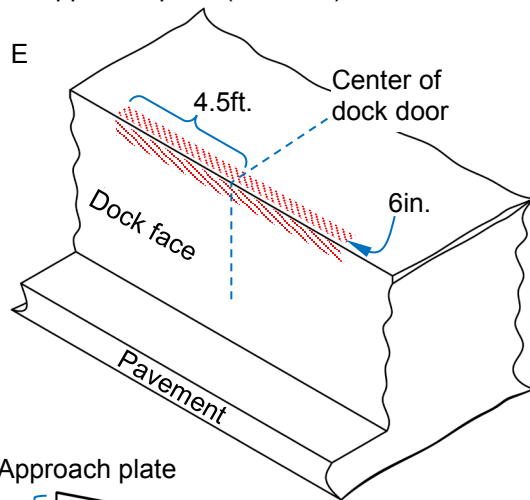

## METHOD 3 (continued): Loading dock without steel edge

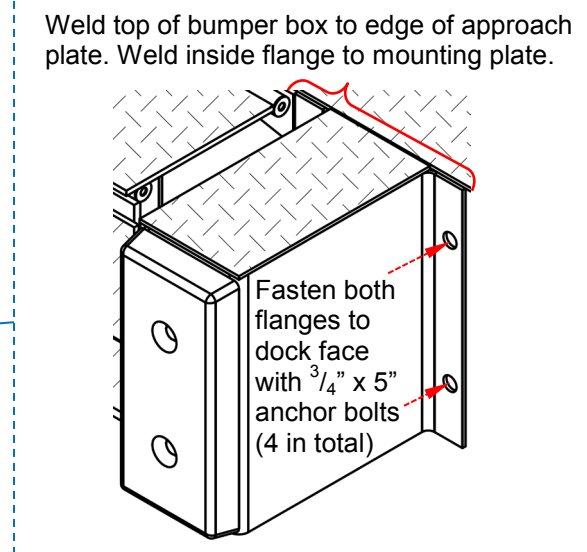
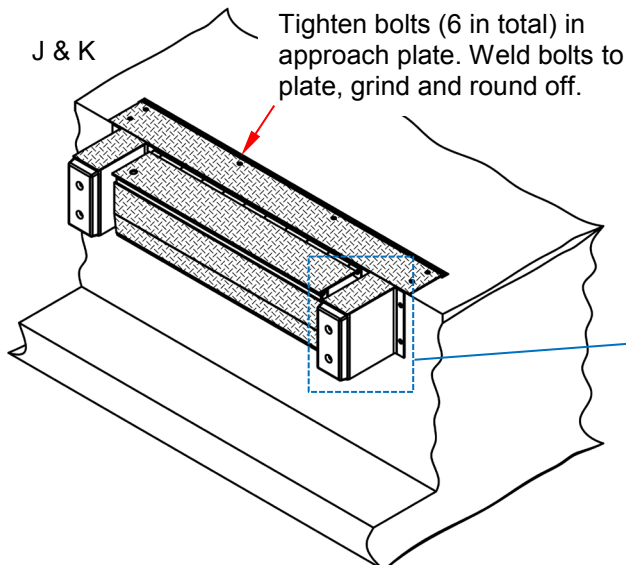
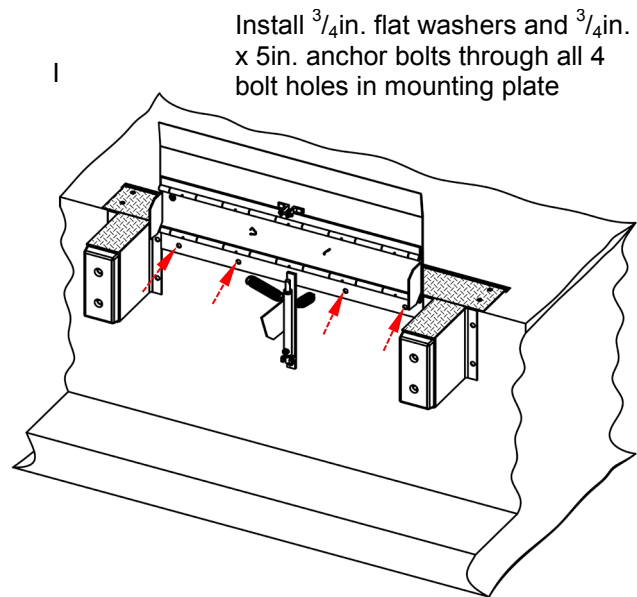
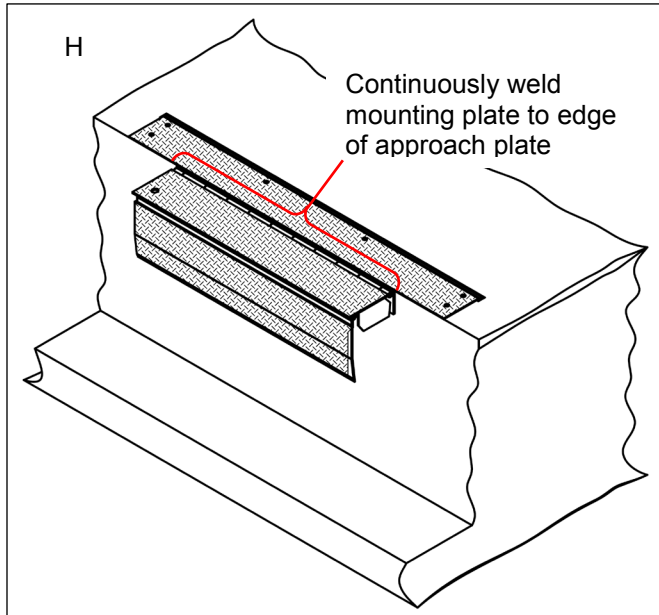

Completing the installation: [Diagrams](#) appear on the next page.

**NOTE:** Numbers in parentheses correspond to part numbers in the bills of materials for the exploded views on pages 3 ([DOCK LEVELER](#)) & 4 ([HAND PUMP](#)).

After the leveler is attached to the loading dock, the hydraulic and electrical control systems must be assembled.

1. Attach the top of the cylinder rod to the cylinder bracket on the underside of the bridge plate with the bolt (17165) and lock nut (37127). The cylinder must remain retracted.
2. The hydraulic fluid reservoir ships with a shipping plug. Remove the shipping plug from the reservoir and replace it with the breather vent (99-616-001).
3. Mount the [hand pump](#) close to the leveler inside the loading dock to protect it from the elements. If necessary, drill a hole through the exterior wall of the dock for the hydraulic hose.
  - a. The unit includes 180" (457cm) of hydraulic hose to connect the hand pump to the deck cylinder. When shipped, the hose is not connected to the hand pump or the cylinder. Feed the hose through the hole in the wall; then connect the hose to the threaded connector on the pump body. Connect the other end of the hose to the threaded connector at the base of the cylinder.
  - b. A mounting plate (06-016-009) is included for attaching the hand pump to a wall. Select an attachment location that is close to the leveler and allows the operator to see the entire dock leveler as well as be able to clearly see into the trailers serviced by the leveler.

4. Lubricate all hinges by applying grease to all of the *grease zerks*. Reapply grease at least every 3 months or more regularly if the leveler is under heavy use (more than 10 cycles per day).

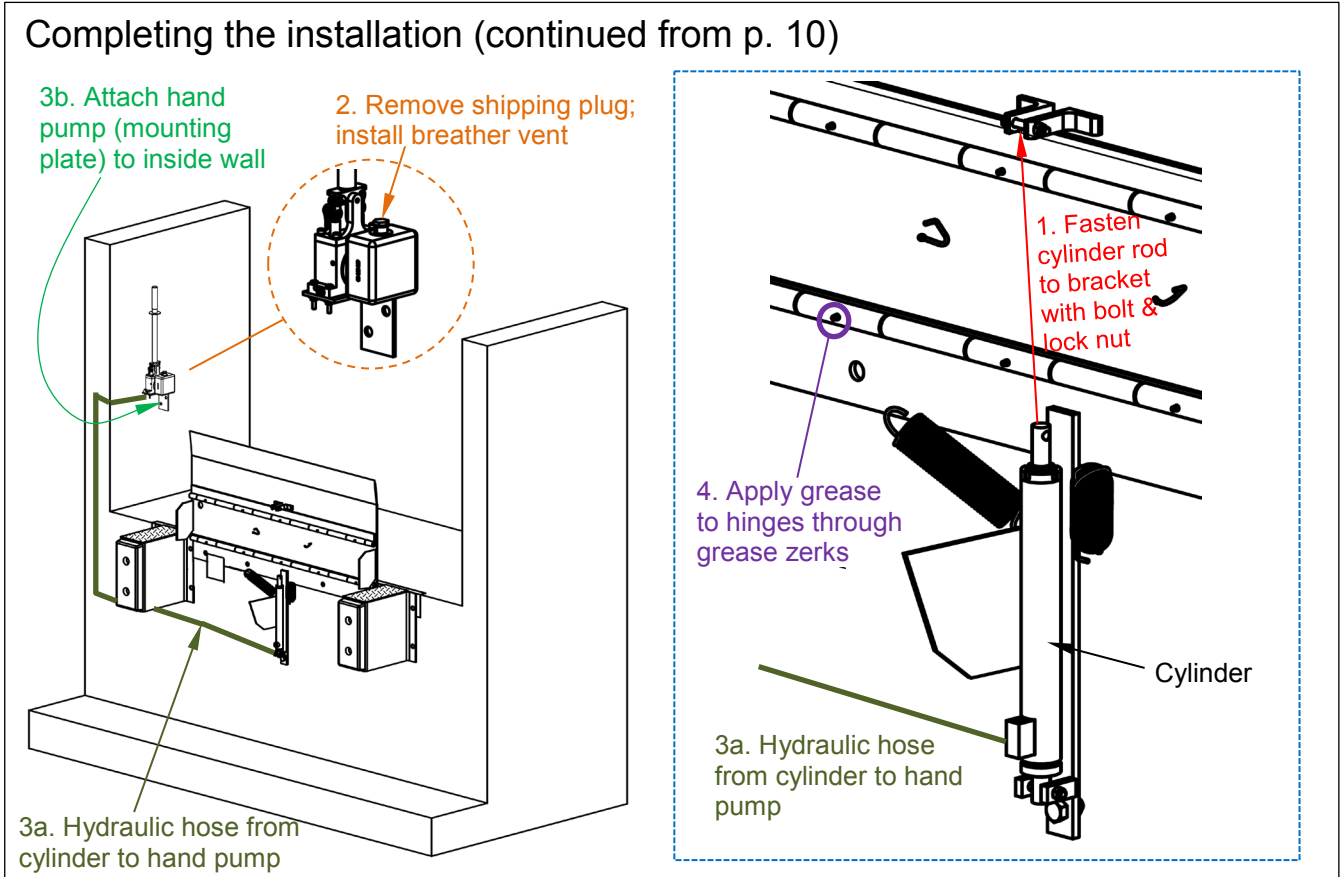

## MANUAL HYDRAULIC PUMP (“HAND PUMP”)

PP-series dock levelers use a manual-hydraulic pump to raise and extend the dock plate and bridge plate. All hydraulic components are rated for 3,000 psi working pressure. Moving the pump handle back-and-forth draws oil out of the reservoir/tank and circulates it through the hydraulic circuit. The pump body houses all valves in the circuit. A hose provides a passage for oil to travel between the reservoir and the cylinder. As the cylinder fills with pressurized oil, the cylinder rod extends. The cylinder rod is connected to the underside of the bridge plate. As the cylinder rod extends, it lifts the dock plate and extends the bridge plate. When the bridge plate is fully extended, carefully open the release valve by pulling the release lever away from the pump body. The lever will toggle into an open position. **The release valve must remain open while the ramp is used.** The cylinder rod retracts and causes the bridge plate to descend. The bridge plate eventually lands on the floor of a parked trailer/vehicle and bridges the gap between the loading dock and the trailer/vehicle.

The following descriptions further explain the functions of noteworthy components of the hydraulic system. Also refer to [HAND PUMP EXPLODED VIEW](#) on p. 4:

- A. **Pump:** The pump is coupled directly to reservoir. Moving the handle draws oil from the reservoir.
- B. **Pump Body:** The following components are housed within the pump body:
  1. **Relief valve (99-153-006; 210bar):** At pressures greater than 1,500 psi, the valve opens and allows fluid to flow back into the reservoir.
  2. **Flow control valve (99-153-038; 1gpm):** Regulates the lowering rate of the leveler.
  3. **Release/Lowering Valve (99-153-080):** Allows oil to flow when closed; prevents oil flow when closed.

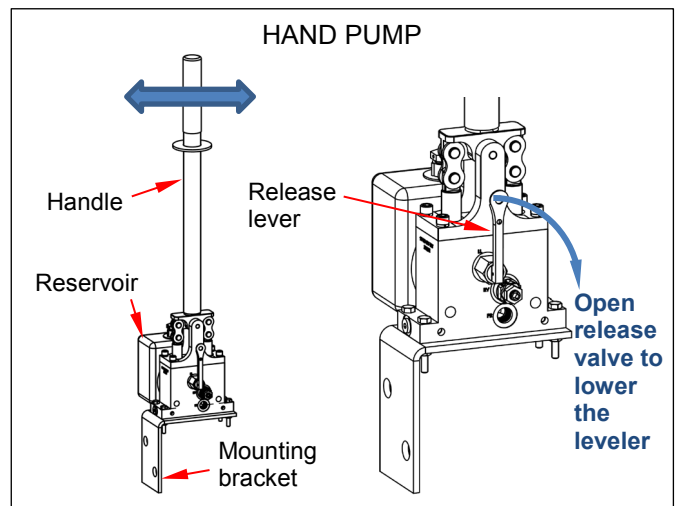

- C. **Hydraulic cylinder:** A displacement-style cylinder that raises and lowers the dock plate and bridge plate.
- D. **Hydraulic fluid:** The system uses HO150 hydraulic fluid. Any anti-wear hydraulic oil with a viscosity grade of 150 SUS at 100°F (ISO 32 at 40°C), such as: AW 32 or a non-synthetic transmission fluid is acceptable.

## OPERATION

Park the freight carrying vehicle/trailer at the dock, i.e. at rest against the dock bumpers with wheels properly chocked. Make sure that the release valve lever is closed (upright). Grasp the operator handle and move it back-and-forth. Oil is drawn from the reservoir and flows into the pump. The pump pushes pressurized oil through the manifold, through the hose, and into the cylinder. As oil accumulates in the cylinder, the cylinder rod extends. The extending cylinder rod presses on the underside of the bridge plate. The bridge plate pivots upwards. Both the bridge plate and the dock plate elevate. When the plates are maximally elevated, open the release valve by pulling the release lever away from the pump body. The plates descend until the bridge plate rests on the trailer.

When unloading operations are finished, the freight-carrying vehicle should simply drive away from the dock. Be certain that nobody is in the vicinity of the leveler because it swiftly falls once the bridge plate slides off of the trailer/vehicle. Close the release valve by moving the lever to the upright position.

## AIR PURGING PROCEDURE

Air can become trapped inside the hydraulic circuit. If this happens, you might notice that the leveler descends to some degree on its own. Air must be removed from the circuit if this happens.

1. Lower the leveler and disconnect the cylinder from the bridge plate by removing the clevis pin.
2. Lay the cylinder on a flat surface with the hose on top.
3. Loosen the hose fitting but do not disconnect the hose. Wrap a rag around the fitting.
4. Circulate oil to the cylinder by slowly moving the handle back and forth. Air and oil will sputter from the fitting. When no more air is present, tighten the fitting.
5. Reattach the cylinder to the bridge plate.

## TROUBLESHOOTING

Contact the Technical Service department for assistance with issues not covered in this guide. [Contact information](#) is provided on the cover page of this manual.

Issue	Cause	Solution
I move the handle but leveler does not rise.	<ol style="list-style-type: none"> <li>1. Pump failing to pressurize hydraulic system</li> <li>2. Load applied to the leveler. The leveler will only lift its own weight.</li> <li>3. Too little oil in reservoir.</li> <li>4. Pinched/kinked hose.</li> <li>5. Pump is air locked.</li> <li>6. Pressure setting of relief valve needs adjustment.</li> <li>7. Debris on seat of relief valve.</li> </ol>	<ol style="list-style-type: none"> <li>1. Contact <a href="#">TECHNICAL SERVICE</a>.</li> <li>2. Unload the leveler.</li> <li>3. Add oil to within 1in. of top of reservoir.</li> <li>4. Straighten hose.</li> <li>5. Remove air from pump. See <a href="#">AIR PURGING PROCEDURE</a> on p. 12.</li> <li>6. Contact <a href="#">TECHNICAL SERVICE</a>.</li> <li>7. Remove relief valve; clean debris from valve seat in pump body.</li> </ol>
A lot of force required to move handle.	<ol style="list-style-type: none"> <li>8. Pressure relief valve opening at full system pressure.</li> <li>9. Load applied to deck.</li> </ol>	<ol style="list-style-type: none"> <li>8. Check for frame damage or binding at the hinges. Check for overload condition.</li> <li>9. Remove load from deck.</li> </ol>
Have to keep pumping handle to maintain cylinder rod extension.	<ol style="list-style-type: none"> <li>10. Release valve allowing oil to flow back to the tank.</li> </ol>	<ol style="list-style-type: none"> <li>10. Make sure release lever is up (valve closed). If lever is up, then valve must be inspected. Remove release valve, inspect, clean, and replace as necessary.</li> </ol>
Pump feels spongy or cylinder rod extends in jerks.	<ol style="list-style-type: none"> <li>11. Too little oil in reservoir.</li> <li>12. Air in hydraulic circuit.</li> </ol>	<ol style="list-style-type: none"> <li>11. Add oil until within 1in. of top of reservoir.</li> <li>12. Purge air from system. See <a href="#">AIR PURGING PROCEDURE</a>.</li> </ol>
Cylinder rod retracts very slowly or too rapidly.	<ol style="list-style-type: none"> <li>13. Flow control valve obstructed</li> </ol>	<ol style="list-style-type: none"> <li>13. Remove valve; inspect for debris or non-operational spool.</li> </ol>



## RECORD OF SATISFACTORY CONDITION (THE “RECORD”)

Once the unit is installed, make a detailed record of its condition and operation. Include observations about hinges, the hydraulic system (cylinder, pump, handle, hoses, reservoir, couplings, etc.), welds, the frame (particularly the mounting plate and cylinder mounting brackets), dock plate, bridge plate, and bumper assemblies. Thoroughly photograph the unit in both the raised and home positions. Photograph all labels. Describe where each label is located. Move the pump handle back-and-forth until the leveler is fully extended/raised; then open the release valve and watch the leveler descend to the home position. Write a detailed description of the operation cycle and/or make a video recording of the leveler in operation. Collect all writings, photographs, and recordings in a file. This file is a record of the unit in satisfactory condition. During future inspections, compare your observations to the record to determine if the unit is in satisfactory condition.

## INSPECTIONS AND MAINTENANCE

Apply all relevant inspection procedures from your copy of MH30.1 as well as the following instructions. Inspections and maintenance should only be performed by qualified persons. Compare the results of each inspection to the [RECORD OF SATISFACTORY CONDITION](#). Do not use the leveler unless all parts are in satisfactory condition. Replace parts that are not in satisfactory condition before returning the unit to service. Only use manufacturer-approved replacement parts to restore the unit to satisfactory condition. **DON'T GUESS! If you have any questions about the condition of your leveler, contact the [TECHNICAL SERVICE](#) department.** The phone number is provided on the cover page of this manual. Never make temporary repairs of damaged or missing parts.

Secure the leveler in the extended position before beginning maintenance. For example, use at least 2 props or attach a locking plate clamp to the bridge plate and lift it with a device like a hoist or forklift boom. It is strongly recommended that more than one method of securing the leveler be applied each time it is serviced to provide redundancy if one method fails, e.g. a prop is knocked out of place.

- (A) **Initial inspection.** Prior to use, any new, altered, modified, or repaired dock leveler shall be inspected by a qualified person. Examine the unit for damage such as cracked metal, cracked welds, severe rusting or corrosion. Repair damaged welds. Appropriately patch damaged metal. Closely examine the springs, mounting plates, and anchor points since they are in direct contact with the loading dock. Make sure that all anchor bolts are tightly fastened to the dock. Check for free motion in the hinges. Apply a general-purpose grease lubricant through the grease nipples in both hinges. Check hinges for freedom of motion. Make sure all labels are in place & in easily readable condition. See [LABELING DIAGRAM](#) on [p. 14](#).
- (B) **Frequent inspection.**
- 1) At the beginning of each shift, a designated person must:
    - i. Clean dirt, debris, and fluids from the dock plate, bridge plate, and approach ramp (if installed).
    - ii. Examine hydraulic hoses for kinks, cuts, and other damage.
  - 2) At least once per week:
    - i. Damage and deformation of the structural members, cylinder brackets, etc.
    - ii. Run the leveler through a complete cycle. Listen for unusual noises. Watch the dock plate and bridge plate for binding or unusual movement. Grease the hinges if the plates are noisy as they move but are otherwise in satisfactory condition.
- (C) Inspect the following **at least once per month**:
- 1.) Oil leaks – check the hose, cylinder, fittings, etc. for oil leaks. Also check the oil level in the reservoir. Oil should be 1” to 1½” below the fill hole in the reservoir. If you need to add oil, or if the oil needs to be replaced, only use anti-wear hydraulic oil with a viscosity grade of 150 SUS at 100°F, (ISO 32 at 40°C), for example AW 32 or HO 150 hydraulic oil or a non-synthetic transmission fluid. Synthetic transmission fluid can be used, but the system must first be flushed with the synthetic fluid before the reservoir is filled.
  - 2.) Hydraulic hose and electrical wiring – check the hose and electrical wires for damage. Replace the hose if it is leaking, bulging, or cracking.
  - 3.) Hinge and cylinder pivot points – check for excessive wear at all pivot points. Apply grease to all hinges through the grease zerks. Examine both cylinder mounting brackets for damage.
  - 4.) Welds – check all welds for cracks and signs of metal fatigue, especially around hinges and cylinder mounting brackets.
  - 5.) Hardware – examine each anchor bolt and the concrete around it. Tighten any bolt that is loose. The leveler must be rigidly anchored to the dock at all times. The frame should not move (e.g. rock or wobble) while the leveler operates. Make sure that the bolt holes in the mounting plate are not elongating, cracking, etc. Also inspect the cylinder mounting bolts (part no. 17165 in [EXPLODED VIEW](#) on p. 3).
  - 6.) Labels – confirm that each label is in place and that all parts of each label (signal word panel and safety messages) are easily readable. Refer to the [LABELING DIAGRAM](#) on p. 14.

7.) Leveler surfaces - Clean the surfaces of the leveler. Remove corrosion/rust and apply touchup paint to all areas where the finish is damaged.

(D) Yearly Maintenance

- 1.) Thoroughly grease the hinges and both cylinder pivot points. See [EXPLODED VIEW](#) on p. 3.
- 2.) The oil should be changed if it darkens, becomes gritty, or has a milky appearance (indicating the presence of water). Replace the original oil with anti-wear hydraulic oil, viscosity grade 150 SUS at 100°F, (ISO 32 at 40°C). Examples of replacement oils include AW 32 or HO 150 hydraulic oil or a non-synthetic transmission fluid. Synthetic transmission fluid can be used only if the system is flushed with the synthetic fluid before the reservoir is filled.

### LABELING DIAGRAM

Label content and location are subject to change so your product might not be labeled exactly as shown. Compare the diagram below to your [RECORD OF SATISFACTORY CONDITION](#). If there are any differences between actual labeling and this diagram, contact [TECHNICAL SERVICE](#) and report the differences. Replace all labels that are damaged, missing, or not easily readable (e.g. faded). To order replacement labels or to inquire whether your unit is properly labeled, contact the technical service and parts department online at [http://www.vestilmfg.com/parts\\_info.htm](http://www.vestilmfg.com/parts_info.htm) or by calling (260) 665-7586 and asking for the Parts Department.



A: Label 206 (Applied to oil reservoir/tank)



B: Label 584 (Applied to oil reservoir/tank)



C: Label 1153 (Applied to outside surface of foot guard)

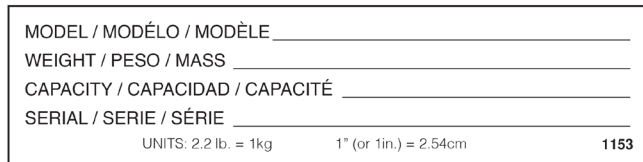

D: Label 1121 (Applied to both foot guards)



## LIMITED WARRANTY

Vestil Manufacturing Corporation (“Vestil”) warrants this product to be free of defects in material and workmanship during the warranty period. Our warranty obligation is to provide a replacement for a defective, original part covered by the warranty after we receive a proper request from the Warrantee (you) for warranty service.

### Who may request service?

Only a warrantee may request service. You are a warrantee if you purchased the product from Vestil or from an authorized distributor AND Vestil has been fully paid.

### Definition of “original part”?

An original part is a part used to make the product as shipped to the Warrantee.

### What is a “proper request”?

A request for warranty service is proper if Vestil receives: 1) a photocopy of the Customer Invoice that displays the shipping date; AND 2) a written request for warranty service including your name and phone number. Send requests by one of the following methods:

US Mail	Fax	Email
Vestil Manufacturing Corporation 2999 North Wayne Street, PO Box 507 Angola, IN 46703	(260) 665-1339 Phone (260) 665-7586	<a href="mailto:info@vestil.com">info@vestil.com</a> Enter “Warranty service request” in subject field.

In the written request, list the parts believed to be defective and include the address where replacements should be delivered. After Vestil receives your request for warranty service, an authorized representative will contact you to determine whether your claim is covered by the warranty. Before providing warranty service, Vestil will require you to send the entire product, or just the defective part (or parts), to its facility in Angola, IN.

### What is covered under the warranty?

The warranty covers defects in the following original, dynamic parts: motors, hydraulic pumps, motor controllers, and cylinders. It also covers defects in original parts that wear under normal usage conditions (“wearing parts”), such as bearings, hoses, wheels, seals, brushes, and batteries.

### How long is the warranty period?

The warranty period for original dynamic components is 1 year. For wearing parts, the warranty period is 90 days. Both warranty periods begin on the date Vestil ships the product to the Warrantee. If the product was purchased from an authorized distributor, the periods begin when the distributor ships the product. Vestil may, at its sole discretion, extend a warranty period for products shipped from authorized distributors by up to 30 days to account for shipping time.

### If a defective part is covered by the warranty, what will Vestil do to correct the problem?

Vestil will provide an appropriate replacement for any *covered* part. An authorized representative of Vestil will contact you to discuss your claim.

### What is not covered by the warranty?

The Warrantee (you) is responsible for paying labor costs and freight costs to return the product to Vestil for warranty service.

### Events that automatically void this Limited Warranty.

- Misuse;
- Negligent assembly, installation, operation or repair;
- Installation/use in corrosive environments;
- Inadequate or improper maintenance;
- Damage sustained during shipping;
- Collisions or other accidents that damage the product;
- Unauthorized modifications: Do not modify the product IN ANY WAY without first receiving written authorization from Vestil.

### Do any other warranties apply to the product?

Vestil Manufacturing Corp. makes no other express warranties. All implied warranties are disclaimed to the extent allowed by law. Any implied warranty not disclaimed is limited in scope to the terms of this Limited Warranty. Vestil makes no warranty or representation that this product complies with any state or local design, performance, or safety code or standard. Noncompliance with any such code or standard is not a defect in material or workmanship.

