

# SERVICE & OPERATING MANUAL

## Original Instructions



### Certified Quality



ISO 9001 Certified  
ISO 14001 Certified



Warren Rupp, Inc.  
A Unit of IDEX Corporation  
800 N. Main St.,  
Mansfield, Ohio 44902 USA  
Telephone (419) 524.8388  
Fax (419) 522.7867  
SANDPIPERPUMP.COM



©2017 Warren Rupp, Inc.

# HDB2 / HDB50

## Heavy Duty Ball Valve

### Design Level 4

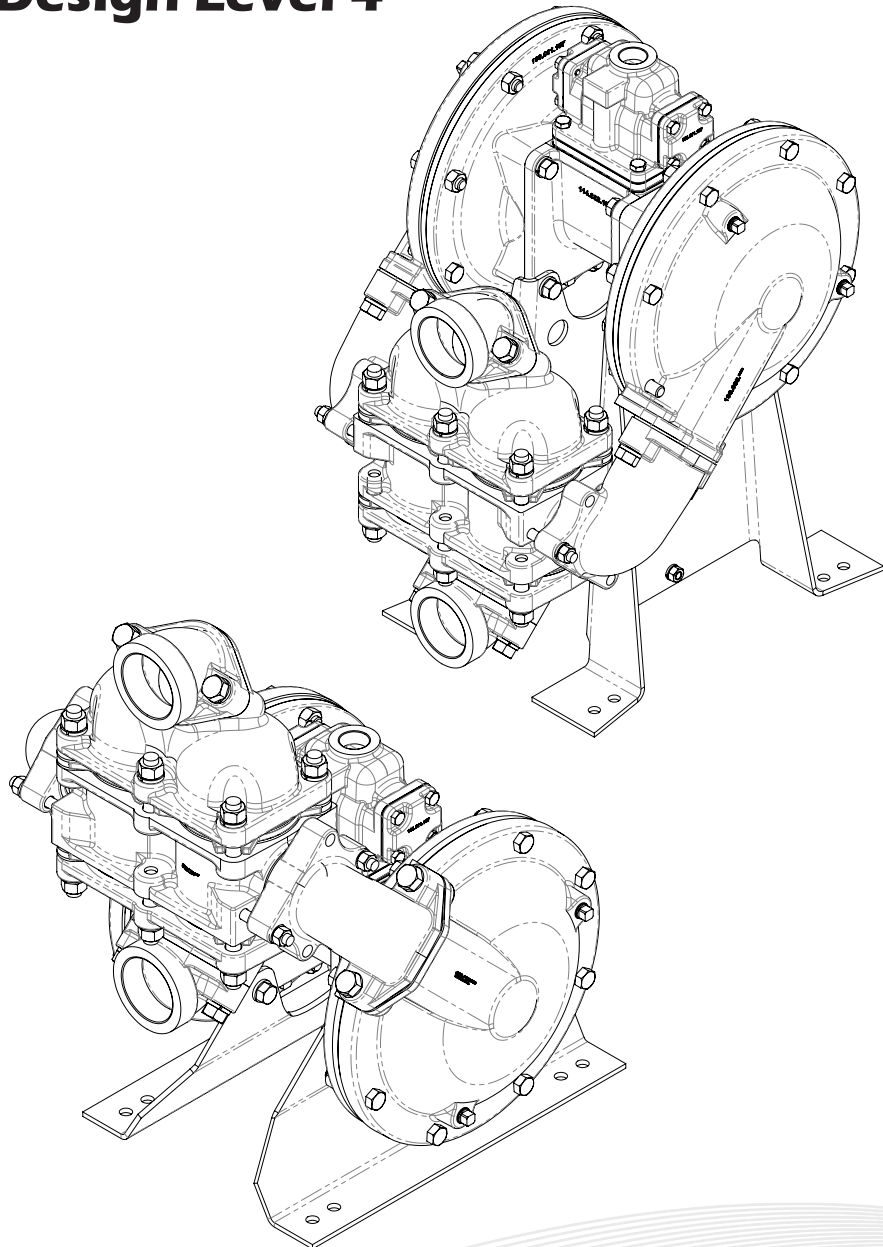

1: PUMP SPECS

2: INSTAL & OP

3: EXP VIEW

4: AIR END

5: WET END

6: OPTIONAL

7: WARRANTY

**SANDPIPER**<sup>®</sup>  
A WARREN RUPP, INC. BRAND

SANDPIPERPUMP.COM

# Safety Information

## IMPORTANT



Read the safety warnings and instructions in this manual before pump installation and start-up. Failure to comply with the recommendations stated in this manual could damage the pump and void factory warranty.



When the pump is used for materials that tend to settle out or solidify, the pump should be flushed after each use to prevent damage. In freezing temperatures the pump should be completely drained between uses.

## CAUTION



Before pump operation, inspect all fasteners for loosening caused by gasket creep. Retighten loose fasteners to prevent leakage. Follow recommended torques stated in this manual.



Nonmetallic pumps and plastic components are not UV stabilized. Ultraviolet radiation can damage these parts and negatively affect material properties. Do not expose to UV light for extended periods of time.



**WARNING**  
The use of non-OEM replacement parts will void (or negate) agency certifications, including CE, ATEX, CSA, 3A and EC1935 compliance (Food Contact Materials). Warren Rupp, Inc. cannot ensure nor warrant non-OEM parts to meet the stringent requirements of the certifying agencies.

## WARNING



When used for toxic or aggressive fluids, the pump should always be flushed clean prior to disassembly.



Before maintenance or repair, shut off the compressed air line, bleed the pressure, and disconnect the air line from the pump. Be certain that approved eye protection and protective clothing are worn at all times. Failure to follow these recommendations may result in serious injury or death.



Airborne particles and loud noise hazards. Wear eye and ear protection.



In the event of diaphragm rupture, pumped material may enter the air end of the pump, and be discharged into the atmosphere. If pumping a product that is hazardous or toxic, the air exhaust must be piped to an appropriate area for safe containment.



Take action to prevent static sparking. Fire or explosion can result, especially when handling flammable liquids. The pump, piping, valves, containers and other miscellaneous equipment must be properly grounded.



This pump is pressurized internally with air pressure during operation. Make certain that all fasteners and piping connections are in good condition and are reinstalled properly during reassembly.



Use safe practices when lifting

## ATEX Pumps - Conditions For Safe Use

1. Ambient temperature range is as specified in tables 1 to 3 on the next page (per Annex I of DEKRA 18ATEX0094X)
2. ATEX compliant pumps are suitable for use in explosive atmospheres when the equipment is properly grounded in accordance with local electrical codes
3. **Non-Metallic ATEX Pumps only — See Explanation of Pump Nomenclature / ATEX Details Page**  
Conductive Polypropylene, conductive Acetal or conductive PVDF pumps are not to be installed in applications where the pumps may be subjected to oil, greases and hydraulic liquids.
4. The optionally provided solenoids shall be protected by a fuse corresponding to its rated current (max  $3 \cdot I_{rat}$  according to EN 60127) or by a motor protecting switch with short circuit and thermal instantaneous tripping (set to the rated current) as short circuit protection. For solenoids with a very low rated current, a fuse with the lowest current value according to the indicated standard will be sufficient. The fuse may be accommodated in the associated supply unit or shall be separately arranged. The rated voltage of the fuse shall be equal or greater than the stated rated voltage of the solenoid. The breaking capacity of the fuse shall be as high as or higher than the maximum expected short circuit current at the location of the installation (usually 1500 A). The maximum permissible ripple is 20% for all dc solenoids.  
**\*Not applicable for all pump models — See Explanation of Pump Nomenclature / ATEX Details Page**
5. When operating pumps equipped with non-conductive diaphragms that exceed the maximum permissible projected area, as defined in EN ISO 80079-36 : 2016 section 6.7.5 table 8, the following protection methods must be applied
  - Equipment is always used to transfer electrically conductive fluids or
  - Explosive environment is prevented from entering the internal portions of the pump, i.e. dry running.
6. Pumps provided with the pulse output kit and used in the potentially explosive atmosphere caused by the presence of the combustible dust shall be installed in such a way that the pulse output kit is protected against impact  
**\*Not applicable for all pump models — See Explanation of Pump Nomenclature / ATEX Details Page**

# Temperature Tables

**Table 1. Category 1 & Category 2 ATEX Rated Pumps**

Ambient Temperature Range [°C]	Process Temperature Range [°C] <sup>1</sup>	Temperature Class	Maximum Surface Temperature [°C]
-20°C to +60°C	-20°C to +80°C	T5	T100°C
	-20°C to +108°C	T4	T135°C
	-20°C to +160°C	T3	T200°C
	-20°C to +177°C	(225°C) T2	

<sup>1</sup>Per CSA standards ANSI LC6-2018 US & Canadian Technical Letter R14, G-Series Natural Gas Models are restricted to (-20°C to + 80°C) process temperature

**Table 2. Category 2 ATEX Rated Pumps Equipped with Pulse Output Kit or Integral Solenoid:**

Ambient Temperature Range [°C]	Process Temperature Range [°C]	Temperature Class	Maximum Surface Temperature [°C]	Options	
				Pulse Output Kit	Integral Solenoid
-20°C to +60°C	-20°C to +100°C	T5	T100	X	
-20°C to +50°C	-20°C to +100°C	T5	T100		X

<sup>2</sup>ATEX Pulse output or Integral Solenoid Not Available For All Pump Models See Explanation of Pump Nomenclature / ATEX Details Page

**Table 3. Category M1 ATEX Rated Pumps for Mining**

Ambient Temperature Range [°C]	Process Temperature Range [°C]
-20°C to +60°C	-20°C to +150°C

Note: The ambient temperature range and the process temperature range should not exceed the operating temperature range of the applied non-metallic parts as listed in the manuals of the pumps.

# Table of Contents

1: PUMP SPECS

## **SECTION 1: PUMP SPECIFICATIONS.....1**

- Explanation of Nomenclature
- Performance
- Materials
- Dimensional Drawings

2: INSTAL & OP

## **SECTION 2: INSTALLATION & OPERATION ...5**

- Principle of Pump Operation
- Recommended Installation Guide
- Troubleshooting Guide

3: EXP VIEW

## **SECTION 3: EXPLODED VIEW.....8**

- Composite Repair Parts Drawing
- Composite Repair Parts List
- Down Ported Option Drawing
- Material Codes

4: AIR END

## **SECTION 4: AIR END .....11**

- Air Distribution Valve Assembly
- Pilot Valve Assembly

5: WET END

## **SECTION 5: WET END.....13**

- Diaphragm Servicing

6: OPTIONAL

## **SECTION 7: WARRANTY & CERTIFICATES ..14**

- Warranty
- CE Declaration of Conformity - Machinery
- ATEX Declaration of Conformity

7: WARRANTY

# Explanation of Pump Nomenclature

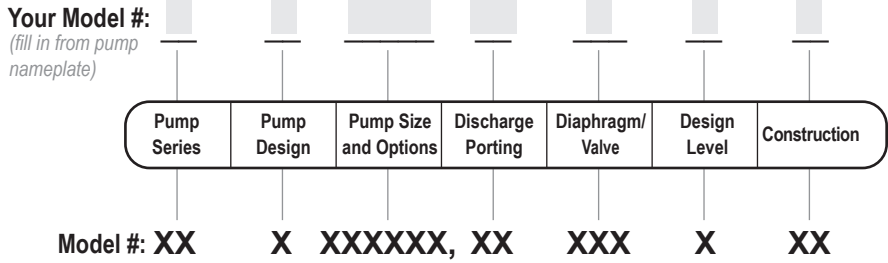

### Pump Series

**HD** Heavy Duty

### Pump Design

**B** Solid Ball

### Pump Size & Options

**2** 2"

**50** 2"

**P1** Intrinsically Safe ATEX Compliant Pulse Output

**SB** Stainless-Brass sleeve and spool set

### Discharge Porting Position

**D** Down Ported

**T** Top

### Diaphragm Check Valve Materials

**B** Nitrile

**C** FKM with PTFE

**F** FDA Accepted White Nitrile

**GN** Neoprene Backup with PTFE Overlay and PTFE Check Balls

**GR** Hytrel Backup w/ PTFE Overlay/PTFE Balls

**GS** Santoprene Backup with PTFE overlay and PTFE Check Balls

**GZ** PTFE/Nitrile Bonded One-Piece/PTFE Balls

**H** EPDM with PTFE

**I** EPDM

**N** Neoprene

**R** Hytrel

**S** Santoprene

**U** Santoprene with PTFE

**V** FKM

### Design Level

**4**

### Construction

**A** Aluminum Wetted, Aluminum Air

**CI** Cast Iron Wetted, Aluminum Air

**II** Cast Iron Wetted, Cast Iron Air

**SI** Stainless Steel Wetted, Cast Iron Air

**SS** Stainless Steel Wetted, Aluminum Air

**HC** Alloy-C Wetted, Aluminum Air

**HI** Alloy-C Wetted, Cast Iron Air

Your Serial #: (fill in from pump nameplate) \_\_\_\_\_

## ATEX Detail

	ATEX Details	Construction	Options
	II 1 G Ex h IIC T5...225°C (T2) Ga II 1D Ex h IIIC T100°C...T200°C Da I M1 Ex h I Ma	SI, HI, II	00
	II 2 G Ex h IIC T5...225°C (T2) Gb II 2 D Ex h IIIC T100°C...T200°C Db	A, CI, SS, HC	00
	II 2 G Ex h ia IIC T5 Gb II 2 D Ex h ia IIIC T100°C Db	A, CI, II, HI, HC, SI, SS	P1

# Performance

## HDB2/HDB50

### SUCTION/DISCHARGE PORT SIZE

- HDB2: 2" NPT
- HDB50: 2" BSP (Tapered)

### CAPACITY

- 0 to 135 gallons per minute (0 to 511 liters per minute)

### AIR DISTRIBUTION VALVE

- No-lube, no-stall design

### SOLIDS-HANDLING

- Up to .38 in. (9 mm)

### HEADS UP TO

- 125 psi or 289 ft. of water (8.8 Kg/cm<sup>2</sup> or 88 meters)

### MAXIMUM OPERATING PRESSURE

- 125 psi (8.6 bar)

### DISPLACEMENT/STROKE

- .46 Gallon / 1.7 liter

### SHIPPING WEIGHT

- Aluminum 90 lbs. (41kg)
- Cast Iron 120 lbs. (55kg)
- Stainless Steel 143 lbs. (66kg)

\*Add 40 lbs for cast iron center section

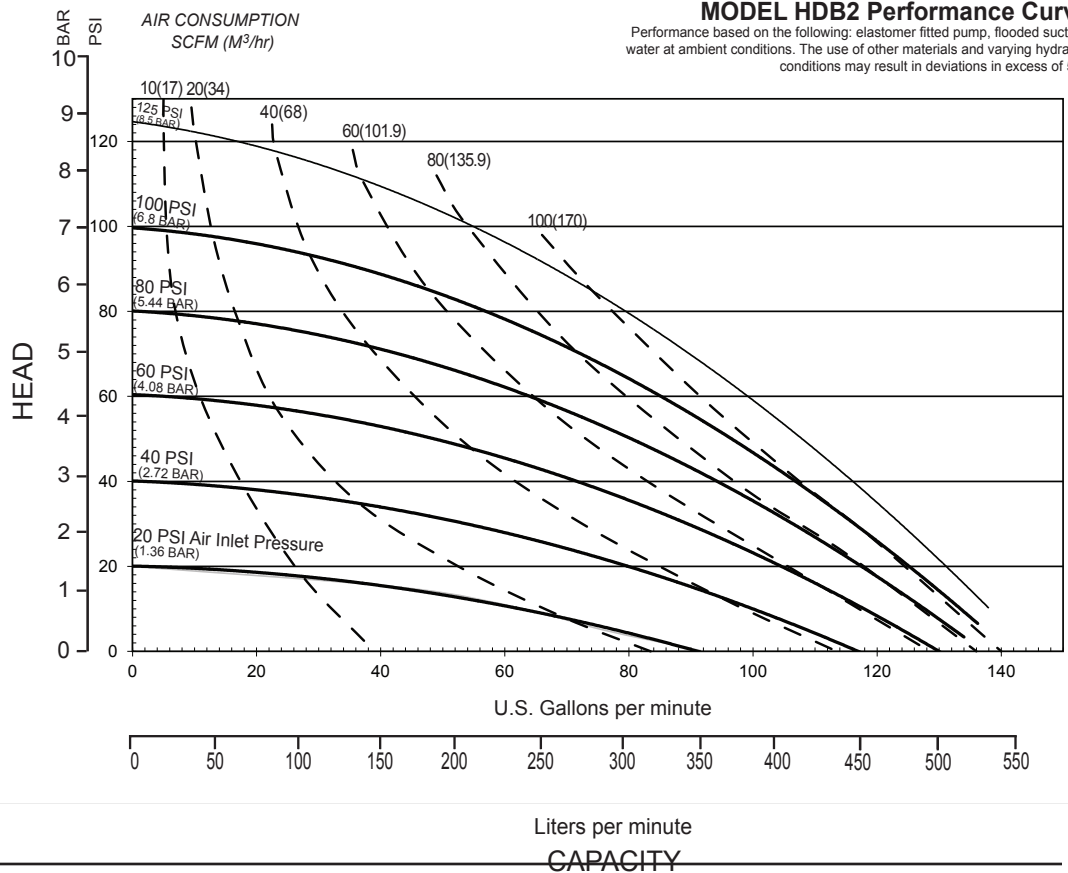

## Materials

Material Profile:	Operating Temperatures:	
	Max.	Min.
<b>Conductive Acetal:</b> Tough, impact resistant, ductile. Good abrasion resistance and low friction surface. Generally inert, with good chemical resistance except for strong acids and oxidizing agents.	190°F 88°C	-20°F -29°C
<b>EPDM:</b> Shows very good water and chemical resistance. Has poor resistance to oils and solvents, but is fair in ketones and alcohols.	280°F 138°C	-40°F -40°C
<b>FKM:</b> (Fluorocarbon) Shows good resistance to a wide range of oils and solvents; especially all aliphatic, aromatic and halogenated hydrocarbons, acids, animal and vegetable oils. Hot water or hot aqueous solutions (over 70°F(21°C)) will attack FKM.	350°F 177°C	-40°F -40°C
<b>Hytre®:</b> Good on acids, bases, amines and glycols at room temperatures only.	220°F 104°C	-20°F -29°C
<b>Neoprene:</b> All purpose. Resistance to vegetable oils. Generally not affected by moderate chemicals, fats, greases and many oils and solvents. Generally attacked by strong oxidizing acids, ketones, esters and nitro hydrocarbons and chlorinated aromatic hydrocarbons.	200°F 93°C	-10°F -23°C
<b>Nitrile:</b> General purpose, oil-resistant. Shows good solvent, oil, water and hydraulic fluid resistance. Should not be used with highly polar solvents like acetone and MEK, ozone, chlorinated hydrocarbons and nitro hydrocarbons.	190°F 88°C	-10°F -23°C
<b>Nylon:</b> 6/6 High strength and toughness over a wide temperature range. Moderate to good resistance to fuels, oils and chemicals.	180°F 82°C	32°F 0°C

<b>Polypropylene:</b> A thermoplastic polymer. Moderate tensile and flex strength. Resists strong acids and alkali. Attacked by chlorine, fuming nitric acid and other strong oxidizing agents.	180°F 82°C	32°F 0°C
<b>PVDF:</b> (Polyvinylidene Fluoride) A durable fluoroplastic with excellent chemical resistance. Excellent for UV applications. High tensile strength and impact resistance.	250°F 121°C	0°F -18°C
<b>Santoprene®:</b> Injection molded thermoplastic elastomer with no fabric layer. Long mechanical flex life. Excellent abrasion resistance.	275°F 135°C	-40°F -40°C
<b>UHMW PE:</b> A thermoplastic that is highly resistant to a broad range of chemicals. Exhibits outstanding abrasion and impact resistance, along with environmental stress-cracking resistance.	180°F 82°C	-35°F -37°C
<b>Urethane:</b> Shows good resistance to abrasives. Has poor resistance to most solvents and oils.	150°F 66°C	32°F 0°C
<b>Virgin PTFE:</b> (PFA/TFE) Chemically inert, virtually impervious. Very few chemicals are known to chemically react with PTFE; molten alkali metals, turbulent liquid or gaseous fluorine and a few fluoro-chemicals such as chlorine trifluoride or oxygen difluoride which readily liberate free fluorine at elevated temperatures.	220°F 104°C	-35°F -37°C

Maximum and Minimum Temperatures are the limits for which these materials can be operated. Temperatures coupled with pressure affect the longevity of diaphragm pump components. Maximum life should not be expected at the extreme limits of the temperature ranges.

### Metals:

<b>Alloy C:</b> Equal to ASTM494 CW-12M-1 specification for nickel and nickel alloy.
<b>Stainless Steel:</b> Equal to or exceeding ASTM specification A743 CF-8M for corrosion resistant iron chromium, iron chromium nickel and nickel based alloy castings for general applications. Commonly referred to as 316 Stainless Steel in the pump industry.

For specific applications, always consult the Chemical Resistance Chart.

# Dimensional Drawings

## HDB2 & HDB50, Down Ported

Dimensions are ± .13" (3mm). Figures in parenthesis = millimeters

1: PUMP SPECS

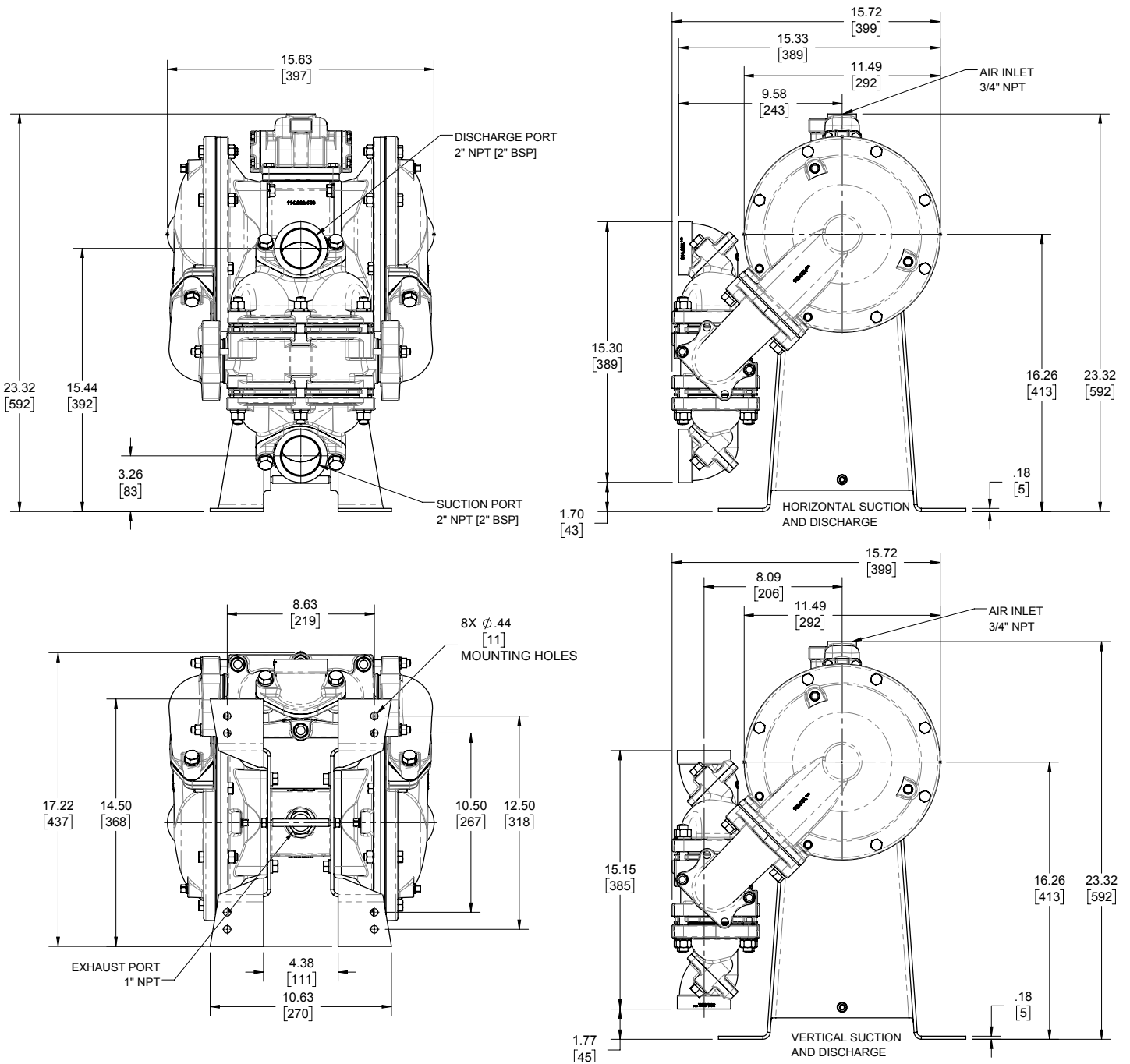

Model HDB2-A features 2" NPT threaded connections.  
 Model HDB50-A features 2" BSP Tapered connections.

# Dimensional Drawings

## HDB2 & HDB50, Top Ported

Dimensions are ± .13" (3mm). Figures in parenthesis = millimeters

1: PUMP SPECS

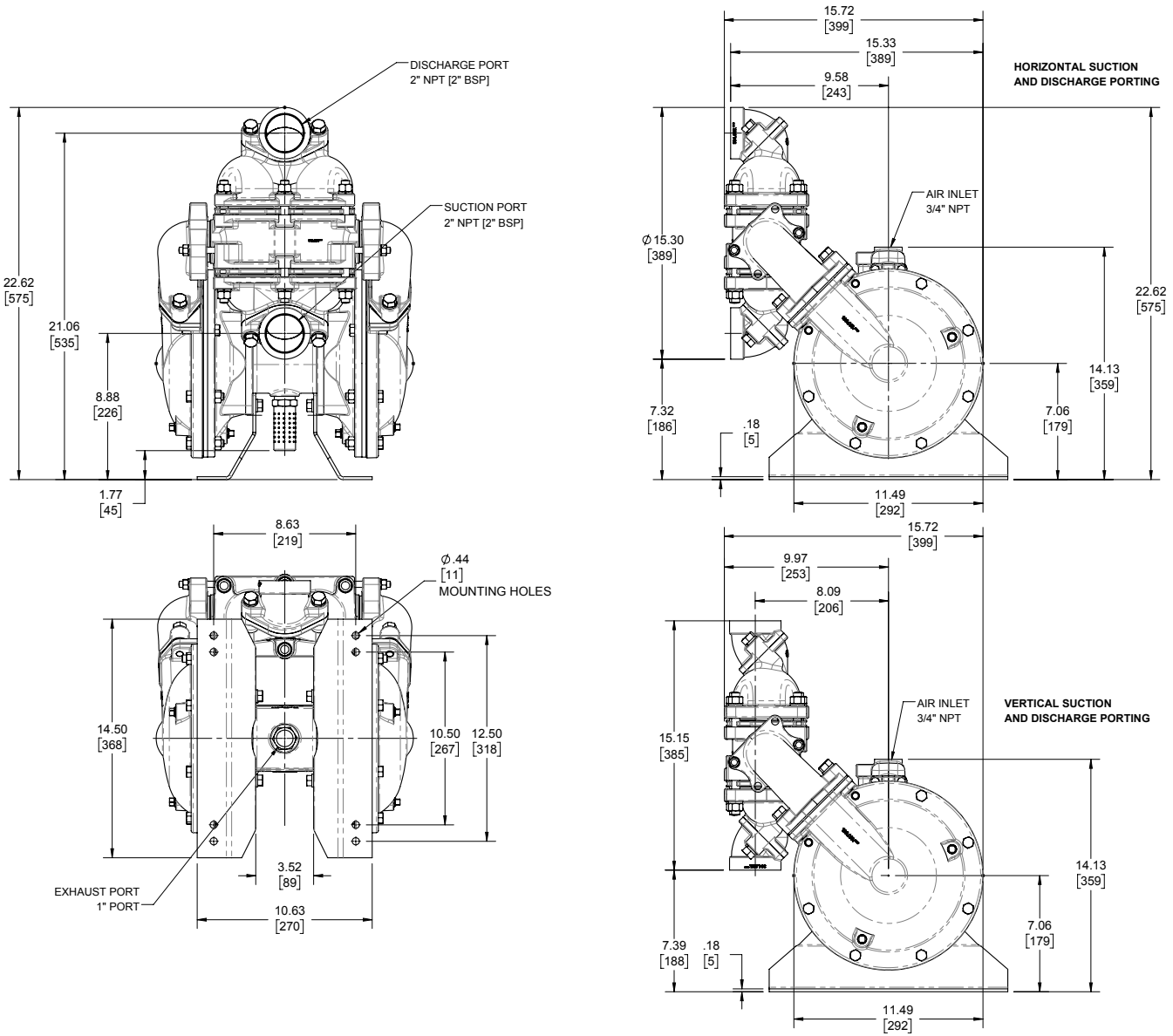

Model HDB2-A features 2" NPT threaded connections.  
Model HDB50-A features 2" BSP Tapered connections.



# Principle of Pump Operation

Air-Operated Double Diaphragm (AODD) pumps are powered by compressed air or nitrogen.

The main directional (air) control valve ① distributes compressed air to an air chamber, exerting uniform pressure over the inner surface of the diaphragm ②. At the same time, the exhausting air ③ from behind the opposite diaphragm is directed through the air valve assembly(s) to an exhaust port ④.

As inner chamber pressure (P1) exceeds liquid chamber pressure (P2), the rod ⑤ connected diaphragms shift together creating discharge on one side and suction on the opposite side. The discharged and primed liquid's directions are controlled by the check valves (ball or flap) ⑥ orientation.

The pump primes as a result of the suction stroke. The suction stroke lowers the chamber pressure (P3) increasing the chamber volume. This results in a pressure differential necessary for atmospheric pressure (P4) to push the fluid through the suction piping and across the suction side check valve and into the outer fluid chamber ⑦.

Suction (side) stroking also initiates the reciprocating (shifting, stroking or cycling) action of the pump. The suction diaphragm's movement is mechanically pulled through its stroke. The diaphragm's inner plate makes contact with an actuator plunger aligned to shift the pilot signaling valve. Once actuated, the pilot valve sends a pressure signal to the opposite end of the main directional air valve, redirecting the compressed air to the opposite inner chamber.

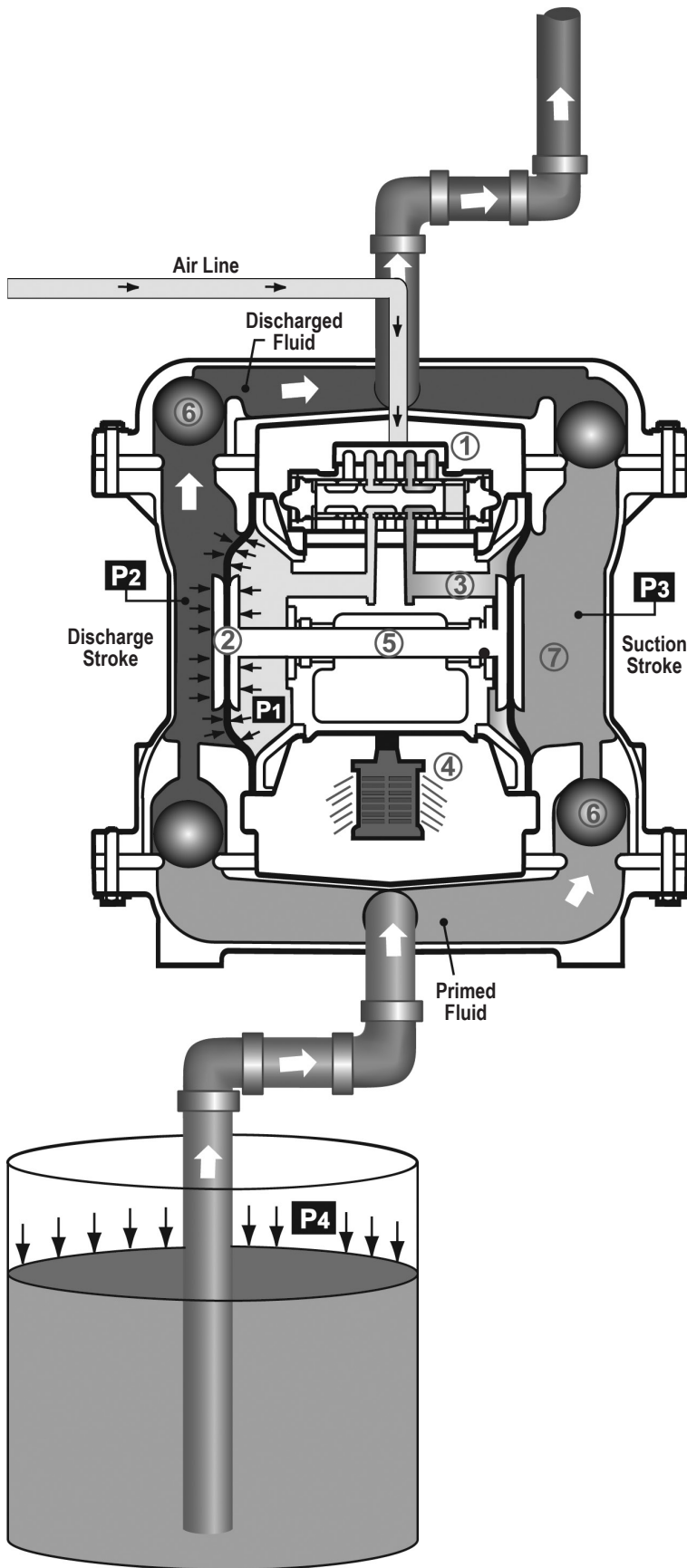

## SUBMERGED ILLUSTRATION

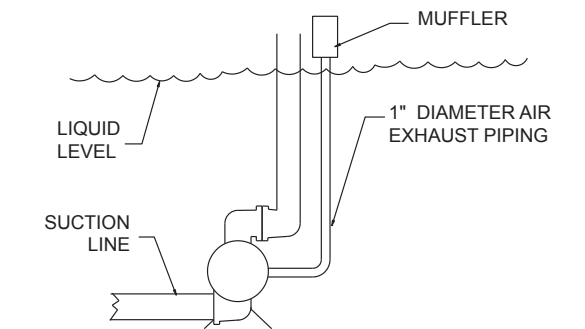

Pump can be submerged if the pump materials of construction are compatible with the liquid being pumped. The air exhaust must be piped above the liquid level. When the pumped product source is at a higher level than the pump (flooded suction condition), pipe the exhaust higher than the product source to prevent siphoning spills.

# Recommended Installation Guide

## Available Accessories:

1. Surge Suppressor
2. Filter/Regulator
3. Air Dryer
4. Lubricator

**Note:** Surge Suppressor and Piping, including air line, must be supported after the flexible connections.

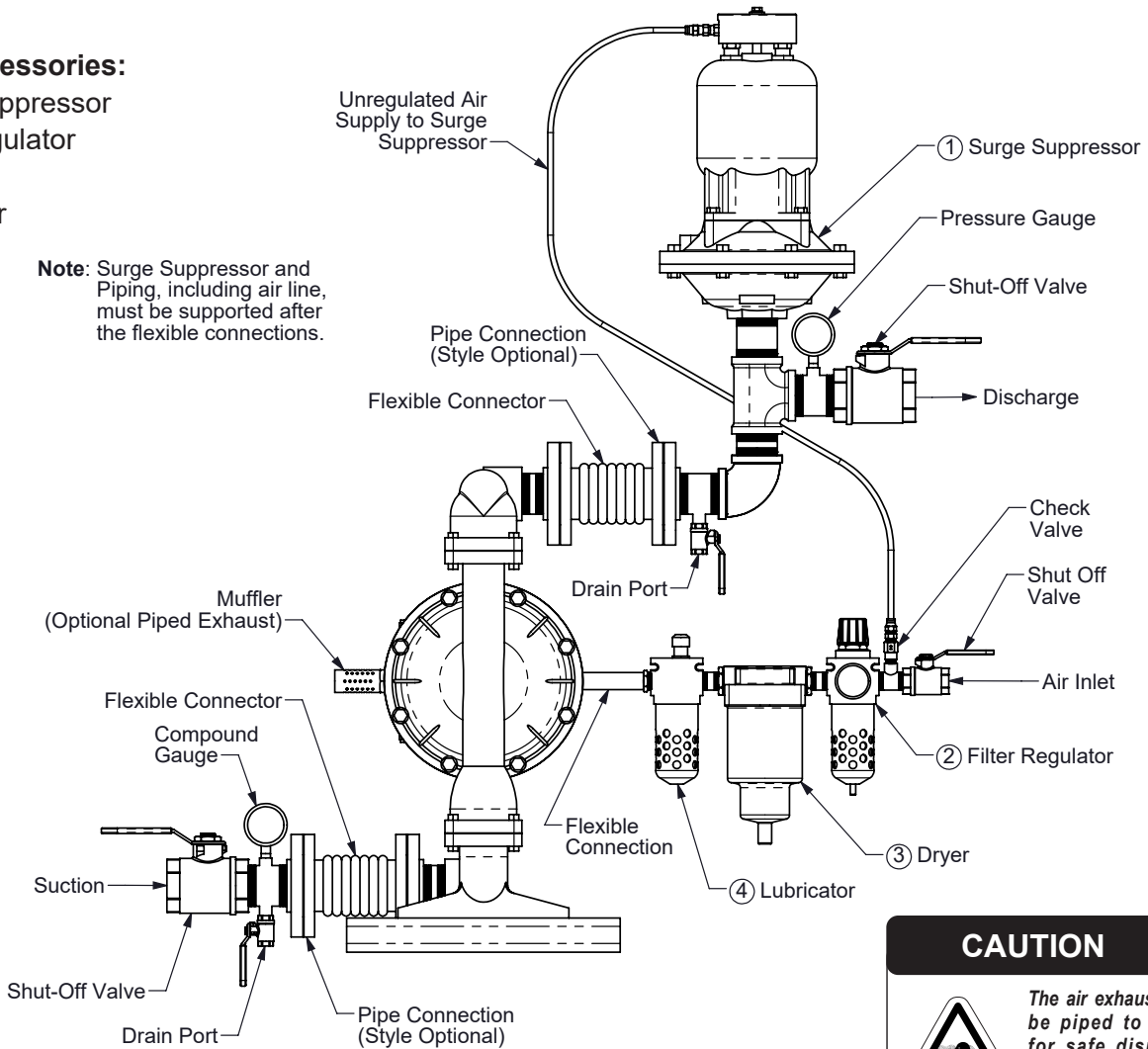

## CAUTION



The air exhaust should be piped to an area for safe disposition of the product being pumped, in the event of a diaphragm failure.

## Installation And Start-Up

Locate the pump as close to the product being pumped as possible. Keep the suction line length and number of fittings to a minimum. Do not reduce the suction line diameter.

## Air Supply

Connect the pump air inlet to an air supply with sufficient capacity and pressure to achieve desired performance. A pressure regulating valve should be installed to insure air supply pressure does not exceed recommended limits.

## Air Valve Lubrication

The air distribution system is designed to operate WITHOUT lubrication. This is the standard mode of operation. If lubrication is desired, install an air line lubricator set to deliver one drop of SAE 10 non-detergent oil for every 20 SCFM (9.4 liters/sec.) of air the pump consumes. Consult the Performance Curve to determine air consumption.

## Air Line Moisture

Water in the compressed air supply may cause icing or freezing of the exhaust air, causing the pump to cycle erratically or stop operating. Water in the air supply can be reduced by using a point-of-use air dryer.

## Air Inlet And Priming

To start the pump, slightly open the air shut-off valve. After the pump primes, the air valve can be opened to increase air flow as desired. If opening the valve increases cycling rate, but does not increase the rate of flow, cavitation has occurred. The valve should be closed slightly to obtain the most efficient air flow to pump flow ratio.

# Troubleshooting Guide

Symptom:	Potential Cause(s):	Recommendation(s):
<b>Pump Cycles Once</b>	Deadhead (system pressure meets or exceeds air supply pressure).	Increase the inlet air pressure to the pump. Pump is designed for 1:1 pressure ratio at zero flow. (Does not apply to high pressure 2:1 units).
	Air valve or intermediate gaskets installed incorrectly.	Install gaskets with holes properly aligned.
	Bent or missing actuator plunger.	Remove pilot valve and inspect actuator plungers.
<b>Pump Will Not Operate / Cycle</b>	Pump is over lubricated.	Set lubricator on lowest possible setting or remove. Units are designed for lube free operation.
	Lack of air (line size, PSI, CFM).	Check the air line size and length, compressor capacity (HP vs. cfm required).
	Check air distribution system.	Disassemble and inspect main air distribution valve, pilot valve and pilot valve actuators.
	Discharge line is blocked or clogged manifolds.	Check for inadvertently closed discharge line valves. Clean discharge manifolds/piping.
	Deadhead (system pressure meets or exceeds air supply pressure).	Increase the inlet air pressure to the pump. Pump is designed for 1:1 pressure ratio at zero flow. (Does not apply to high pressure 2:1 units).
	Blocked air exhaust muffler.	Remove muffler screen, clean or de-ice, and re-install.
	Pumped fluid in air exhaust muffler.	Disassemble pump chambers. Inspect for diaphragm rupture or loose diaphragm plate assembly.
	Pump chamber is blocked.	Disassemble and inspect wetted chambers. Remove or flush any obstructions.
<b>Pump Cycles and Will Not Prime or No Flow</b>	Cavitation on suction side.	Check suction condition (move pump closer to product).
	Check valve obstructed. Valve ball(s) not seating properly or sticking.	Disassemble the wet end of the pump and manually dislodge obstruction in the check valve pocket. Clean out around valve ball cage and valve seat area. Replace valve ball or valve seat if damaged. Use heavier valve ball material.
	Valve ball(s) missing (pushed into chamber or manifold).	Worn valve ball or valve seat. Worn fingers in valve ball cage (replace part). Check Chemical Resistance Guide for compatibility.
	Valve ball(s) / seat(s) damaged or attacked by product.	Check Chemical Resistance Guide for compatibility.
	Check valve and/or seat is worn or needs adjusting.	Inspect check valves and seats for wear and proper setting. Replace if necessary.
	Suction line is blocked.	Remove or flush obstruction. Check and clear all suction screens or strainers.
	Excessive suction lift.	For lifts exceeding 20' of liquid, filling the chambers with liquid will prime the pump in most cases.
	Suction side air leakage or air in product.	Visually inspect all suction-side gaskets and pipe connections.
<b>Pump Cycles Running Sluggish / Stalling, Flow Unsatisfactory</b>	Pumped fluid in air exhaust muffler.	Disassemble pump chambers. Inspect for diaphragm rupture or loose diaphragm plate assembly.
	Over lubrication.	Set lubricator on lowest possible setting or remove. Units are designed for lube free operation.
	Icing.	Remove muffler screen, de-ice, and re-install. Install a point of use air drier.
	Clogged manifolds.	Clean manifolds to allow proper air flow.
	Deadhead (system pressure meets or exceeds air supply pressure).	Increase the inlet air pressure to the pump. Pump is designed for 1:1 pressure ratio at zero flow. (Does not apply to high pressure 2:1 units).
	Cavitation on suction side.	Check suction (move pump closer to product).
	Lack of air (line size, PSI, CFM).	Check the air line size, length, compressor capacity.
	Excessive suction lift.	For lifts exceeding 20' of liquid, filling the chambers with liquid will prime the pump in most cases.
	Air supply pressure or volume exceeds system hd.	Decrease inlet air (press. and vol.) to the pump. Pump is cavitating the fluid by fast cycling.
	Undersized suction line.	Meet or exceed pump connections.
	Restrictive or undersized air line.	Install a larger air line and connection.
	Suction side air leakage or air in product.	Visually inspect all suction-side gaskets and pipe connections.
	Suction line is blocked.	Remove or flush obstruction. Check and clear all suction screens or strainers.
	Pumped fluid in air exhaust muffler.	Disassemble pump chambers. Inspect for diaphragm rupture or loose diaphragm plate assembly.
	Check valve obstructed.	Disassemble the wet end of the pump and manually dislodge obstruction in the check valve pocket.
Check valve and/or seat is worn or needs adjusting.	Inspect check valves and seats for wear and proper setting. Replace if necessary.	
<b>Product Leaking Through Exhaust</b>	Entrained air or vapor lock in chamber(s).	Purge chambers through tapped chamber vent plugs. Purging the chambers of air can be dangerous.
	Diaphragm failure, or diaphragm plates loose.	Replace diaphragms, check for damage and ensure diaphragm plates are tight.
<b>Premature Diaphragm Failure</b>	Diaphragm stretched around center hole or bolt holes.	Check for excessive inlet pressure or air pressure. Consult Chemical Resistance Chart for compatibility with products, cleaners, temperature limitations and lubrication.
	Cavitation.	Enlarge pipe diameter on suction side of pump.
	Excessive flooded suction pressure.	Move pump closer to product. Raise pump/place pump on top of tank to reduce inlet pressure. Install Back pressure device (Tech bulletin 41r). Add accumulation tank or pulsation dampener.
	Misapplication (chemical/physical incompatibility).	Consult Chemical Resistance Chart for compatibility with products, cleaners, temperature limitations and lubrication.
<b>Unbalanced Cycling</b>	Incorrect diaphragm plates or plates on backwards, installed incorrectly or worn.	Check Operating Manual to check for correct part and installation. Ensure outer plates have not been worn to a sharp edge.
	Excessive suction lift.	For lifts exceeding 20' of liquid, filling the chambers with liquid will prime the pump in most cases.
	Undersized suction line.	Meet or exceed pump connections.
	Pumped fluid in air exhaust muffler.	Disassemble pump chambers. Inspect for diaphragm rupture or loose diaphragm plate assembly.
	Suction side air leakage or air in product.	Visually inspect all suction-side gaskets and pipe connections.
	Check valve obstructed.	Disassemble the wet end of the pump and manually dislodge obstruction in the check valve pocket.
	Check valve and/or seat is worn or needs adjusting.	Inspect check valves and seats for wear and proper setting. Replace if necessary.
Entrained air or vapor lock in chamber(s).	Purge chambers through tapped chamber vent plugs.	

For additional troubleshooting tips contact After Sales Support at [service.warrenrupp@idexcorp.com](mailto:service.warrenrupp@idexcorp.com) or 419-524-8388

# Composite Repair Parts Drawing

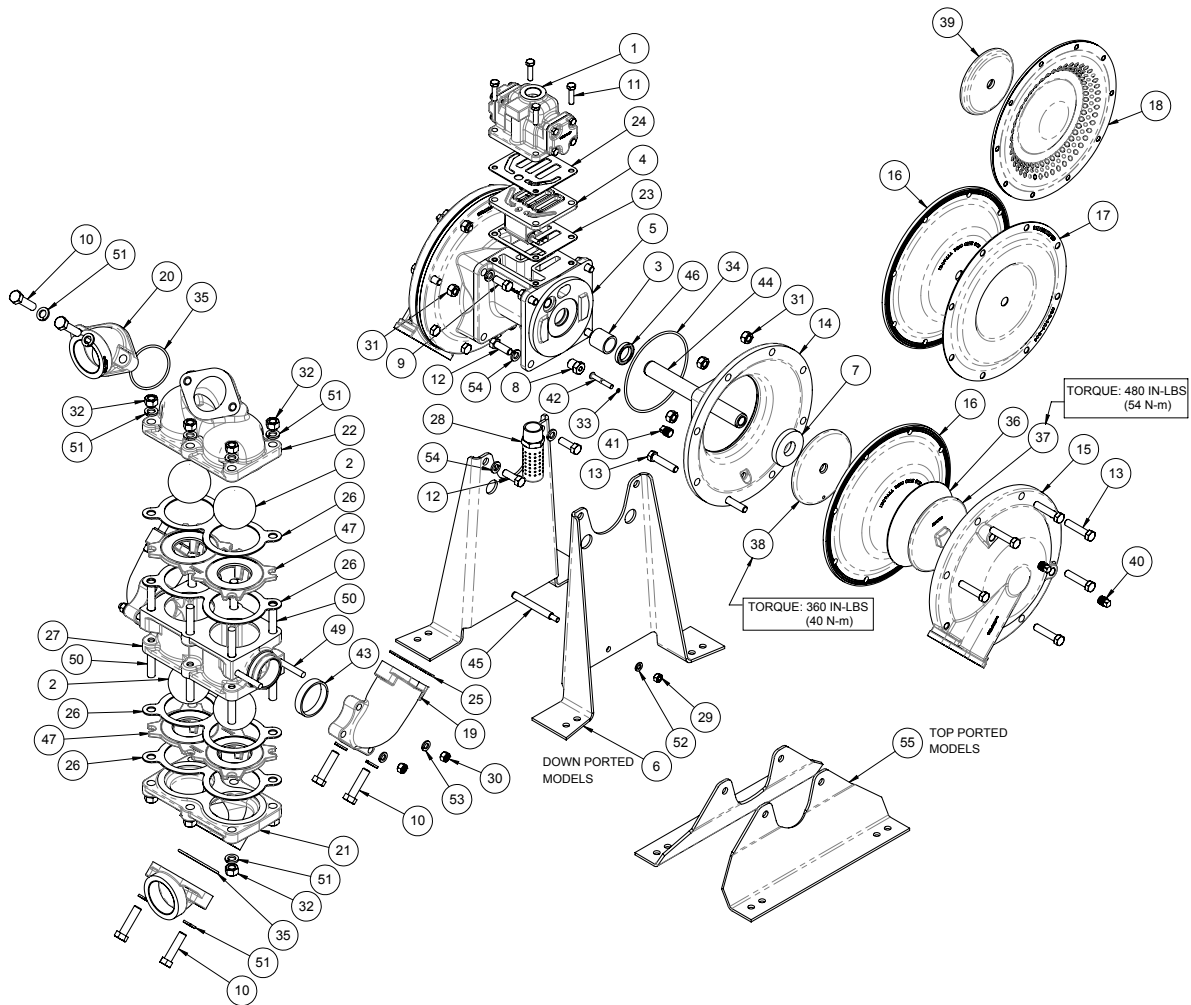

3: EXP VIEW

## Service & Repair Kits

- 476.362.000 Air End Kit**  
Sleeve and Spool Set, O-rings, Bumpers, U-Cup Seals, and Gaskets.
- 476.314.000 Air End Kit**  
Seals, O-rings, Gaskets, Grease Packet Bumpers  
Plunger Actuators, Plunger Bushings
- 476.364.354 Wet End Kit**  
Santoprene Diaphragms, Santoprene Balls, Santoprene  
Wear Pads, Conductive EPDM Seat Gaskets,  
Fiber Manifold Gaskets, EPDM O-rings
- 476.364.360 Wet End Kit**  
Nitrile Diaphragms, Weighted Nitrile Balls, Conductive  
Nitrile Seat Gaskets, Fabric Manifold Gaskets, Nitrile  
O-Rings, Nitrile Wear Pads
- 476.364.364 Wet End Kit**  
EPDM Diaphragms, EPDM Balls, Conductive EPDM  
Seat Gaskets, Fabric Manifold Gaskets, EPDM O-rings,  
EPDM Wear Pads

- 476.364.365 Wet End Kit**  
Neoprene Diaphragms, Weighted Neoprene Balls,  
Conductive Neoprene Seat Gaskets, Fabric Manifold  
Gaskets, Neoprene O-rings, Neoprene Wear Pads
- 476.364.644 Wet End Kit**  
Santoprene Diaphragms, PTFE Balls, Conductive EPDM  
Seat Gaskets, PTFE Manifold Gaskets,  
EPDM O-rings, EPDM Wear Pads
- 476.364.633 Wet End Kit**  
FKM Diaphragms, FKM Wear Pads, PTFE Balls, Conductive  
PTFE Seat Gaskets, FKM Seals, PTFE Encapsulated O-rings
- 476.364.635 Wet End Kit**  
Neoprene Diaphragms, and PTFE Overlay Diaphragm, Balls,  
Sealing Rings, O-rings, & Gaskets
- Conversion Kit Type 3 to Type 4**
- 475.303.379** Check Valve Seat & Conductive Buna Seat Gaskets
- 475.303.384** Check Valve Seat & Conductive Neoprene Seat Gaskets
- 475.303.385** Check Valve Seat & Conductive EPDM Seat Gaskets
- 475.303.608** Check Valve Seat & Conductive PTFE Seat Gaskets

# Composite Repair Parts List

Item	Part Number	Description	Qty.				
1	031.212.156	Air Valve Assy (Aluminum Center - see pg #11 for details)	1	23	360.041.379	Gasket, Pilot Valve	1
	031.212.010	Air Valve Assy (Cast Iron Center)	1	24	360.048.425	Gasket, Air Valve	1
	031.212.001	Air Valve Assy (Alum Center SS/BRASS Slv Spool-High Clearance)	1	25	360.049.425	Gasket, Manifold - Fiber	2
	031.212.004	Air Valve Assy (Alum Center SS/BRASS Slv-Spool)	1		360.049.603	Gasket, Manifold - Gylon	2
	031.213.156	Air Valve Assy (Alum Center - stroke Indicator)	1	26	360.117.379	Gasket, Manifold - Conductive Buna	4
	031.213.010	Air Valve Assy (Cast Iron Center - stroke Indicator)	1		360.117.384	Gasket, Manifold - Conductive Neoprene	4
2	050.017.354	Ball, Check - Santoprene	4		360.117.385	Gasket, Manifold - Conductive EPDM	4
	050.017.360W	Ball, Check - Buna (weighted)	4		360.117.608	Gasket, Manifold - Conductive PTFE	4
	050.017.364W	Ball, Check - EPDM (weighted)	4	27	518.027.156	Manifold (w/ alum wetted) Includes items #49 & #50	1
	050.017.365W	Ball, Check - Neoprene (weighted)	4		518.027.010	Manifold (w/ cast iron wetted) Includes items #49 & #50	1
	050.018.600	Ball, Check - PTFE	4		518.027.110	Manifold (w/ stainless wetted) Includes items #49 & #50	1
3	070.006.170	Bushing, Intermediate (included in item #5)	2	28	518.027.112	Manifold (w/ alloy-C wetted) Includes items #49 & #50	1
4	095.073.001	Pilot Valve Assy	1	29	530.033.000	Muffler, Metal	1
5	114.002.156	Intermediate (w/ aluminum center)	1	30	545.004.330	Nut, Hex 5/16-18 (down ported units only)	2
	114.002.010	Intermediate (w/ cast iron center)	1	31	545.005.330	Nut, Hex 3/8-16	4
6	115.057.080	Bracket, Leg (Down Ported)	2	32	545.007.330	Nut, Hex 7/16-14	12
7	132.002.360	Bumper, Diaphragm	2	33	545.008.330	Nut, Hex 1/2 x 13	12
8	135.016.162	Bushing, Plunger	2	34	560.001.360	O-ring	2
9	170.024.330	Capscrew, Hx-Hd 7/16-14 x 1.00	4	35	560.022.360	O-ring	2
10	170.030.330	Capscrew, Hx-Hd 1/2-13 x 2.00	8		560.047.360	O-ring	2
11	170.045.330	Capscrew, Hx-Hd 5/16-18 x 1.25	4		560.047.364	O-ring	2
12	170.058.330	Capscrew, Hx-Hd 7/16-14 x 1.25	4		560.047.365	O-ring	2
13	170.060.330	Capscrew, Hx-Hd 7/16-14 x 2.00	16	36	560.060.611	O-ring (FKM / PTFE units)	2
14	196.001.157	Chamber, Inner (w/ aluminum center) Includes #41	2		570.009.360	Pad, Wear - Buna	2
	196.001.010	Chamber, Inner (w/ cast iron center) Includes #41	2		570.009.363	Pad, Wear - FKM	2
15	196.035.156	Chamber, Outer (w/ aluminum wetted) Includes #41	2		570.009.364	Pad, Wear - EPDM/Santoprene	2
	196.035.010	Chamber, Outer (w/ cast iron wetted) Includes #40	2	37	570.009.365	Pad, Wear - Neoprene	2
	196.035.110	Chamber, Outer (w/ stainless wetted) Includes #40	2		612.039.157	Plate, Outer Diaphragm Assy (w/ aluminum wetted)	2
	196.035.112	Chamber, Outer (w/ alloy-C wetted) Includes #40	2		612.039.010	Plate, Outer Diaphragm Assy (w/ cast iron wetted)	2
16	286.007.354	Diaphragm - Santoprene	2		612.097.110	Plate, Outer Diaphragm Assy (w/ stainless wetted)	2
	286.007.356	Diaphragm - Hytrel	2		612.097.112	Plate, Outer Diaphragm Assy (w/ alloy-c wetted)	2
	286.007.360	Diaphragm - Buna	2	38	612.047.330	Plate, Inner Diaphragm	2
	286.007.363	Diaphragm - FKM	2		612.215.330	Plate, Inner Diaphragm (w/ Synthesis Diaphs item #18)	2
	286.007.364	Diaphragm - EPDM	2	39	618.003.330	Plug, Pipe 1/4" (w/ aluminum / cast iron wetted)	4
	286.007.365	Diaphragm - Neoprene	2	40	618.003.110	Plug, Pipe 1/4" (w/ stainless wetted)	4
17	286.020.604	Diaphragm, Overlay - PTFE	2		618.003.112	Plug, Pipe 1/4" (w/ alloy-c wetted)	4
18	286.118.000	Diaphragm, Synthesis - One Piece PTFE (uses item #39)	2	41	618.003.330	Plug, Pipe 1/4" (w/ aluminum / cast iron wetted)	2
19	312.033.156	Elbow, Manifold (w/ aluminum wetted)	2	42	620.011.114	Plunger, Actuator	2
	312.033.010	Elbow, Manifold (w/ cast iron wetted)	2	43	675.013.360	Ring, Sealing - Buna	2
	312.033.110	Elbow, Manifold (w/ stainless wetted)	2		675.013.363	Ring, Sealing - FKM	2
	312.033.112	Elbow, Manifold (w/ alloy-C wetted)	2		675.013.364	Ring, Sealing - EPDM	2
20	334.025.156	Porting Flange, Threaded NPT (w/ aluminum wetted)	2		675.013.365	Ring, Sealing - Neoprene	2
	334.025.010	Porting Flange, Threaded NPT (w/ cast iron wetted)	2	44	675.013.600	Ring, Sealing - PTFE	2
	334.025.110	Porting Flange, Threaded NPT (w/ stainless wetted)	2	45	685.007.120	Rod, Diaphragm	1
	334.025.112	Porting Flange, Threaded NPT (w/ alloy-C wetted)	2	46	685.032.080	Rod, Connecting, Foot Bracket	1
	334.025.156E	Porting Flange, Threaded BSPT (w/ aluminum wetted)	2	47	720.004.360	Seal, U-Cup	2
	334.025.010E	Porting Flange, Threaded BSPT (w/ cast iron wetted)	2	48	722.106.110	Seat, Check Valve	2
	334.025.110E	Porting Flange, Threaded BSPT (w/ stainless wetted)	2	49	807.026.330	Stud, Diaphragm Plate (not shown - included with #37)	2
	334.025.112E	Porting Flange, Threaded BSPT (w/ alloy-C wetted)	2	50	807.038.330	Stud, Threaded-3/8", Manifold (included with #27)	4
21	334.026.156	Flange, Suction (w/ aluminum wetted)	1	51	807.039.330	Stud, Threaded-1/2", Manifold (included with #27)	12
	334.026.010	Flange, Suction (w/ cast iron wetted)	1	52	900.003.330	Washer, Lock 1/2"	20
	334.026.110	Flange, Suction (w/ stainless wetted)	1	53	900.004.330	Washer, Lock 5/16" (down ported only)	2
	334.026.112	Flange, Suction (w/ alloy-C wetted)	1	54	900.005.330	Washer, Lock 3/8"	6
22	334.027.156	Flange, Discharge (w/ aluminum wetted)	1	55	900.006.330	Washer, Lock 7/16" (side ported units)	8
	334.027.010	Flange, Discharge (w/ cast iron wetted)	1		115.053.080	Bracket, Leg (Top Ported)	2
	334.027.110	Flange, Discharge (w/ stainless wetted)	1				
	334.027.112	Flange, Discharge (w/ alloy-C wetted)	1				

## LEGEND:

○ = Items contained within Air End Kits

□ = Items contained within Wet End Kits

\* Air End Kit only includes sleeve and spool set, not entire air valve assembly

**Note:** Kits contain components specific to the material codes.

3: EXP VIEW

# Material Codes - The Last 3 Digits of Part Number

000.....Assembly, sub-assembly; and some purchased items	364.....EPDM Rubber Color coded: BLUE
010.....Cast Iron	365.....Neoprene Rubber Color coded: GREEN
015.....Ductile Iron	366.....Food Grade Nitrile
020.....Ferritic Malleable Iron	368.....Food Grade EPDM
080.....Carbon Steel, AISI B-1112	371.....Philthane (Tuftane)
110.....Alloy Type 316 Stainless Steel	374.....Carboxylated Nitrile
111.....Alloy Type 316 Stainless Steel (Electro Polished)	375.....Fluorinated Nitrile
112.....Alloy C	378.....High Density Polypropylene
113.....Alloy Type 316 Stainless Steel (Hand Polished)	379.....Conductive Nitrile
114.....303 Stainless Steel	384.....Conductive Neoprene
115.....302/304 Stainless Steel	385.....Conductive EPDM
117.....440-C Stainless Steel (Martensitic)	408.....Cork and Neoprene
120.....416 Stainless Steel (Wrought Martensitic)	425.....Compressed Fibre
148.....Hardcoat Anodized Aluminum	426.....Blue Gard
150.....6061-T6 Aluminum	440.....Vegetable Fibre
152.....2024-T4 Aluminum (2023-T351)	500.....Delrin® 500
155.....356-T6 Aluminum	502.....Conductive Acetal, ESD-800
156.....356-T6 Aluminum	503.....Conductive Acetal, Glass-Filled
157.....Die Cast Aluminum Alloy #380	506.....Delrin® 150
158.....Aluminum Alloy SR-319	520.....Injection Molded PVDF Natural color
162.....Brass, Yellow, Screw Machine Stock	540.....Nylon
165.....Cast Bronze, 85-5-5-5	542.....Nylon
166.....Bronze, SAE 660	544.....Nylon Injection Molded
170.....Bronze, Bearing Type, Oil Impregnated	550.....Polyethylene
180.....Copper Alloy	551.....Glass Filled Polypropylene
305.....Carbon Steel, Black Epoxy Coated	552.....Unfilled Polypropylene
306.....Carbon Steel, Black PTFE Coated	555.....Polyvinyl Chloride
307.....Aluminum, Black Epoxy Coated	556.....Black Vinyl
308.....Stainless Steel, Black PTFE Coated	558.....Conductive HDPE
309.....Aluminum, Black PTFE Coated	570.....Rulon II®
313.....Aluminum, White Epoxy Coated	580.....Ryton®
330.....Zinc Plated Steel	600.....PTFE (virgin material) Tetrafluorocarbon (TFE)
332.....Aluminum, Electroless Nickel Plated	603.....Blue Gylon®
333.....Carbon Steel, Electroless Nickel Plated	604.....PTFE
335.....Galvanized Steel	606.....PTFE
337.....Silver Plated Steel	607.....Envelon
351.....Food Grade Santoprene®	608.....Conductive PTFE
353.....Geolast; Color: Black	610.....PTFE Encapsulated Silicon
354.....Injection Molded #203-40 Santoprene® Duro 40D +/-5; Color: RED	611.....PTFE Encapsulated FKM
356.....Hytrel®	632.....Neoprene/Hytrel®
357.....Injection Molded Polyurethane	633.....FKM/PTFE
358.....Urethane Rubber (Some Applications) (Compression Mold)	634.....EPDM/PTFE
359.....Urethane Rubber	635.....Neoprene/PTFE
360.....Nitrile Rubber Color coded: RED	637.....PTFE, FKM/PTFE
363.....FKM (Fluorocarbon) Color coded: YELLOW	638.....PTFE, Hytrel®/PTFE
	639.....Nitrile/TFE
	643.....Santoprene®/EPDM
	644.....Santoprene®/PTFE
	656.....Santoprene® Diaphragm and Check Balls/EPDM Seats
	661.....EPDM/Santoprene®
	666.....FDA Nitrile Diaphragm,

PTFE Overlay, Balls, and Seals  
668.....PTFE, FDA Santoprene®/PTFE

- Delrin and Hytrel are registered tradenames of E.I. DuPont.
- Nylatron is a registered tradename of Polymer Corp.
- Gylon is a registered tradename of Garlock, Inc.
- Santoprene is a registered tradename of Exxon Mobil Corp.
- Rulon II is a registered tradename of Dixon Industries Corp.
- Ryton is a registered tradename of Phillips Chemical Co.
- Valox is a registered tradename of General Electric Co.

## RECYCLING

Warren Rupp is an ISO14001 registered company and is committed to minimizing the impact our products have on the environment. Many components of SANDPIPER® AODD pumps are made of recyclable materials. We encourage pump users to recycle worn out parts and pumps whenever possible, after any hazardous pumped fluids are thoroughly flushed. Pump users that recycle will gain the satisfaction to know that their discarded part(s) or pump will not end up in a landfill. The recyclability of SANDPIPER products is a vital part of Warren Rupp's commitment to environmental stewardship.

# Air Distribution Valve Assembly

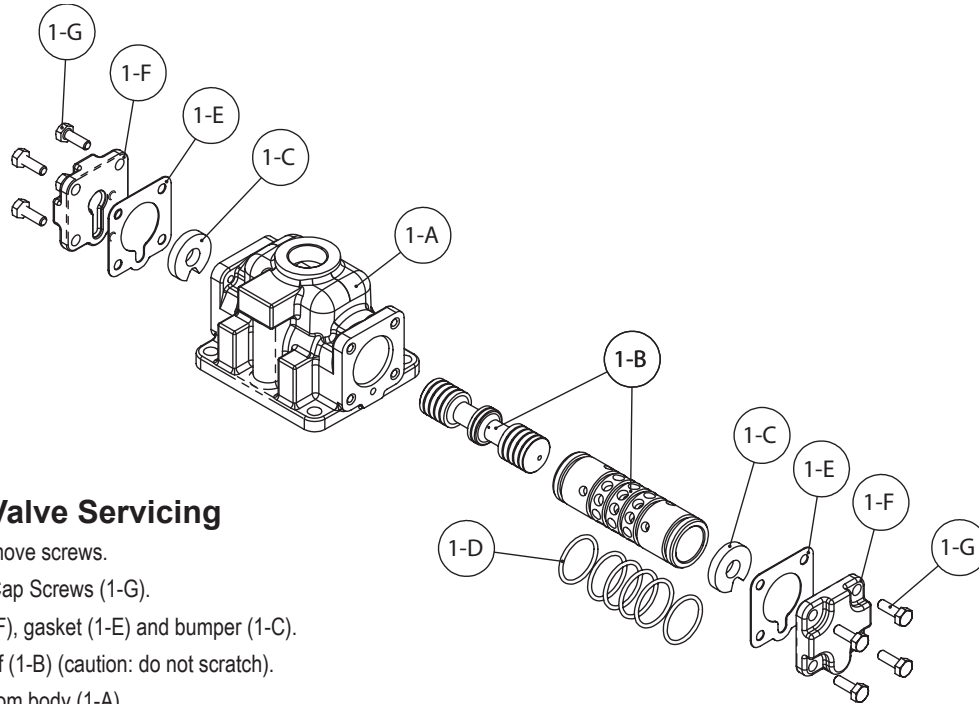

## Air Distribution Valve Servicing

See repair parts drawing, remove screws.

**Step 1:** Remove Hex Head Cap Screws (1-G).

**Step 2:** Remove end cap (1-F), gasket (1-E) and bumper (1-C).

**Step 3:** Remove spool part of (1-B) (caution: do not scratch).

**Step 4:** Press sleeve (1-B) from body (1-A).

**Step 5:** Inspect O-Ring (1-D) and replace if necessary.

**Step 6:** Lightly lubricate O-Rings (1-D) on sleeve (1-B).

**Step 7:** Press sleeve (1-B) into body (1-A).

**Step 8:** Reassemble in reverse order, starting with step 3.

**Note:** Sleeve and spool (1-B) set is match ground to a specified clearance sleeve and spools (1-B) cannot be interchanged.

## MAIN AIR VALVE ASSEMBLY PARTS LIST

Item	Part Number	Description	Qty
1	031.212.156	Air Valve Assembly	1
1-A	095.043.156	Body, Air Valve	1
1-B	031.209.000	Sleeve and Spool Set	1
1-C	132.014.358	Bumper	2
1-D	560.020.360	O-Ring	6
1-E	360.010.425	Gasket	2
1-F	165.011.157	End Cap	2
1-G	170.032.330	Hex Head Capscrew	8

## FOR CAST IRON CENTERS ONLY

Item	Part Number	Description	Qty
1	031.212.010	Air Valve Assembly	1
1-A	095.043.010	Body, Air Valve	1
1-B	031.209.000	Sleeve and Spool Set	1
1-C	132.014.358	Bumper	2
1-D	560.020.360	O-Ring	6
1-E	360.010.425	Gasket	2
1-F	165.011.010	End Cap	2
1-G	170.032.330	Hex Head Capscrew	8

### LEGEND:

○ = Items contained within Air End Kits

**Note:** Kits contain components specific to the material codes.

## IMPORTANT



Read these instructions completely, before installation and start-up. It is the responsibility of the purchaser to retain this manual for reference. Failure to comply with the recommendations stated in this manual will damage the pump, and void factory warranty.

# Pilot Valve Assembly

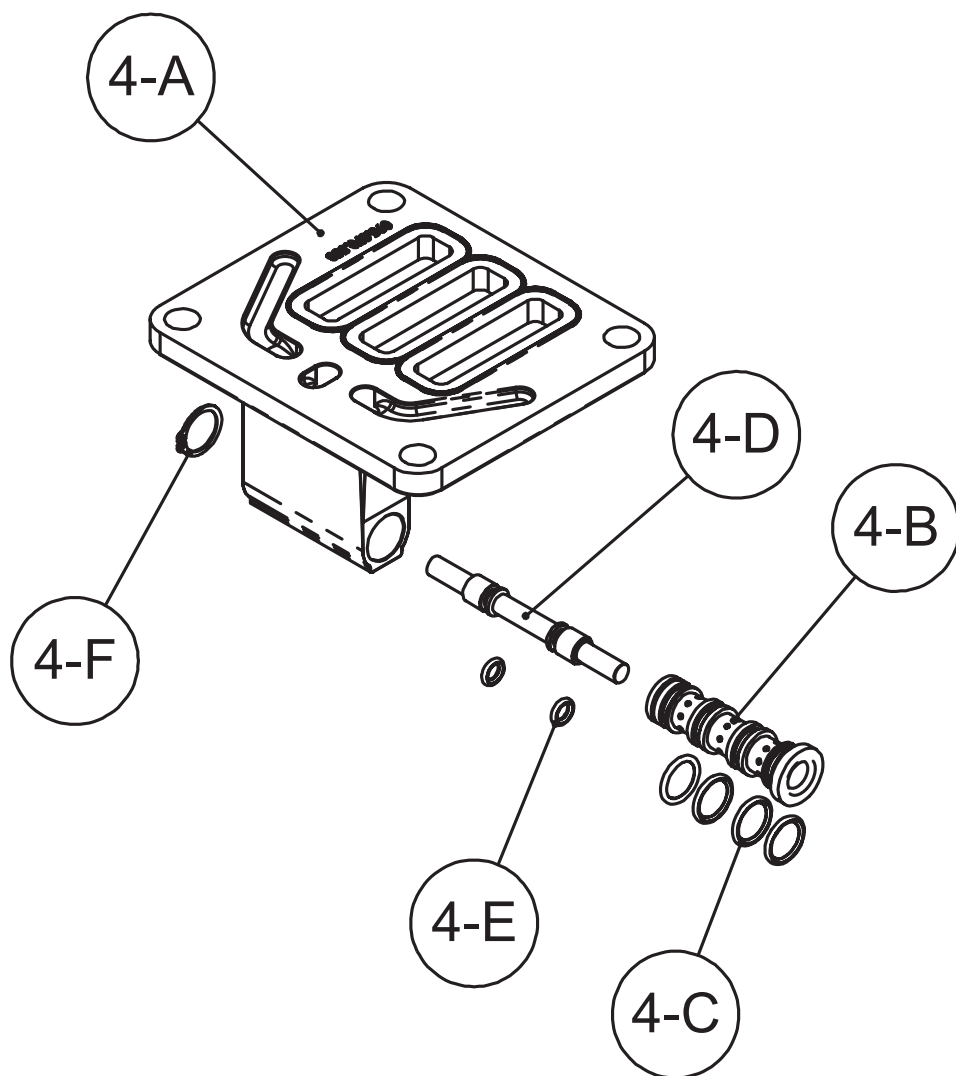

4: AIR END

## Pilot Valve Servicing

With Pilot Valve removed from pump.

**Step 1:** Remove snap ring (4-F).

**Step 2:** Remove sleeve (4-B), inspect O-Rings (4-C), replace if required.

**Step 3:** Remove spool (4-D) from sleeve (4-B), inspect O-Rings (4-E), replace if required.

**Step 4:** Lightly lubricate O-Rings (4-C) and (4-E).

Reassemble in reverse order.

## PILOT VALVE ASSEMBLY PARTS LIST

Item	Part Number	Description	Qty
4	095.073.001	Pilot Valve Assembly	1
4-A	095.070.558	Valve Body	1
4-B	755.025.000	Sleeve (With O-Rings)	1
4-C	560.033.360	O-Ring (Sleeve)	4
4-D	775.026.000	Spool (With O-Rings)	1
4-E	560.023.360	O-Ring (Spool)	2
4-F	675.037.080	Retaining Ring	1

### LEGEND:

○ = Items contained within Air End Kits

**Note:** Kits contain components specific to the material codes.



# Diaphragm Servicing

**Step 1:** With manifolds and outer chambers removed, remove diaphragm assemblies from diaphragm rod. **DO NOT** use a pipe wrench or similar tool to remove assembly from rod. Flaws in the rod surface may damage bearings and seal. Soft jaws in a vise are recommended to prevent diaphragm rod damage.

**Step 1.A: NOTE:** Not all inner diaphragm plates are threaded. Some models utilize a through hole in the inner diaphragm plate. If required to separate diaphragm assembly, place assembly in a vise, gripping on the exterior cast diameter of the inner plate. Turn the outer plate clockwise to separate the assembly.

Always inspect diaphragms for wear cracks or chemical attack. Inspect inner and outer plates for deformities, rust scale and wear. Inspect intermediate bearings for elongation and wear. Inspect diaphragm rod for wear or marks.  
Clean or repair if appropriate. Replace as required.

**Step 2:** Reassembly: There are two different types of diaphragm plate assemblies utilized throughout the Sandpiper product line: Outer plate with a threaded stud, diaphragm, and a threaded inner plate.

Outer plate with a threaded stud, diaphragm, and an inner plate with through hole. Secure threaded inner plate in a vise. Ensure that the plates are being installed with the outer radius against the diaphragm.

**Step 3:** Lightly lubricate, with a compatible material, the inner faces of both outer and inner diaphragm plates when using on non Overlay diaphragms (For EPDM water is recommended). No lubrication is required.

**Step 4:** Push the threaded outer diaphragm plate through the center hole of the diaphragm.  
**Note:** Most diaphragms are installed with the natural bulge out towards the fluid side. S05, S07, and S10 non-metallic units are installed with the natural bulge in towards the air side.

**Step 5:** Thread or place, outer plate stud into the inner plate. For threaded inner plates, use a torque wrench to tighten the assembly together. Torque values are called out on the exploded view.

Repeat procedure for second side assembly. Allow a minimum of 15 minutes to elapse after torquing, then re-torque the assembly to compensate for stress relaxation in the clamped assembly.

**Step 6:** Thread one assembly onto the diaphragm rod with sealing washer (when used) and bumper.

**Step 7:** Install diaphragm rod assembly into pump and secure by installing the outer chamber in place and tightening the capscrews.

**Step 8:** On opposite side of pump, thread the remaining assembly onto the diaphragm rod. Using a torque wrench, tighten the assembly to the diaphragm rod. Align diaphragm through bolt holes, always going forward past the recommended torque. Torque values are called out on the exploded view. **NEVER** reverse to align holes, if alignment cannot be achieved without damage to diaphragm, loosen complete assemblies, rotate diaphragm and reassemble as described above.

**Step 9:** Complete assembly of entire unit.  
One Piece Diaphragm Servicing (Bonded PTFE with integral plate) The One Piece diaphragm has a threaded stud installed in the integral plate at the factory. The inner diaphragm plate has a through hole instead of a threaded hole. Place the inner plate over the diaphragm stud and thread the first diaphragm / inner plate onto the diaphragm rod only until the inner plate contacts the rod. Do not tighten. A small amount of grease may be applied between the inner plate and the diaphragm to facilitate assembly. Insert the diaphragm / rod assembly into the pump and install the outer chamber. Turn the pump over and thread the second diaphragm / inner plate onto the diaphragm rod. Turn the diaphragm until the inner plate contacts the rod and hand tighten the assembly. Continue tightening until the bolt holes align with the inner chamber holes. **DO NOT LEAVE THE ASSEMBLY LOOSE.**

## IMPORTANT



*Read these instructions completely, before installation and start-up. It is the responsibility of the purchaser to retain this manual for reference. Failure to comply with the recommendations stated in this manual will damage the pump, and void factory warranty.*

# 5 - YEAR Limited Product Warranty

Warren Rupp, Inc. ("Warren Rupp") warrants to the original end-use purchaser that no product sold by Warren Rupp that bears a Warren Rupp brand shall fail under normal use and service due to a defect in material or workmanship within five years from the date of shipment from Warren Rupp's factory. Warren Rupp brands include Warren Rupp®, SANDPIPER®, SANDPIPER Signature Series™, MARATHON®, Porta-Pump®, SludgeMaster™ and Tranquilizer®.

The use of non-OEM replacement parts will void (or negate) agency certifications, including CE, ATEX, CSA, 3A and EC1935 compliance (Food Contact Materials). Warren Rupp, Inc. cannot ensure nor warrant non-OEM parts to meet the stringent requirements of the certifying agencies.

~ See [sandpiperpump.com/content/warranty-certifications](http://sandpiperpump.com/content/warranty-certifications) for complete warranty, including terms and conditions, limitations and exclusions. ~

**WARREN  
RUPP, INC.**

## Declaration of Conformity

Manufacturer: Warren Rupp, Inc., 800 N. Main Street  
Mansfield, Ohio, 44902 USA

Certifies that Air-Operated Double Diaphragm Pump Series: HDB, HDF, M Non-Metallic, S Non-Metallic, M Metallic, S Metallic, T Series, G Series, U Series, EH and SH High Pressure, RS Series, W Series, F Series, SMA and SPA Submersibles, and Tranquilizer® Surge Suppressors comply with the European Community Directive 2006/42/EC on Machinery, according to Annex VIII.

This product has used Harmonized Standard EN809:2012, Pumps and Pump Units for Liquids - Common Safety Requirements, to verify conformance.

  
Signature of authorized person

October 20, 2005  
Date of issue

Authorised Representative:  
IDEX Pump Technologies  
R79 Shannon Industrial Estate  
Shannon, Co. Clare, Ireland

Director of Engineering  
Title

February 27, 2017  
Date of revision

Attn: Barry McMahon



Revision Level: F



# EU Declaration of Conformity

**Manufacturer:**

Warren Rupp, Inc.  
A Unit of IDEX Corporation  
800 North Main Street  
Mansfield, OH 44902 USA

Warren Rupp, Inc. declares that Air Operated Double Diaphragm Pumps (AODD) and Surge Suppressors listed below comply with the requirements of **Directive 2014/34/EU** and all applicable standards.

**Applicable Standards**

- EN ISO 80079-36: 2016
- EN ISO 80079-37: 2016
- EN ISO 60079-25: 2010

**1. AODD Pumps and Surge Suppressors** - Technical File No.: 20310400-1410/MERHazardous Location Applied:

II 2 G Ex h IIC T5...225°C (T2) Gb  
 II 2 D Ex h IIIC T100°C...T200°C Db  
II 2 G Ex h IIB T5...225°C (T2) Gb  
II 2 D Ex h IIIB T100°C...T200°C Db

Note: Containment Duty (ST Series) are restricted to gas group IIB due to area of non-conductive sight tubes

- Metallic pump models with external aluminum components (S Series, HD Series, G Series, DMF Series, MSA Series, U Series, F Series, T Series, EH Series, SH Series, GH Series, ST Series)
- Conductive plastic pump models with integral muffler (S Series, PB Series)
- Tranquilizer® surge suppressors

**2. AODD Pumps** - EU Type Examination Certificate No.: DEKRA 18ATEX0094X - DEKRA Certification B.V. (0344)Hazardous Location Applied:

I M1 Ex h I Ma  
II 1 G Ex h IIC T5...225°C (T2) Ga  
II 1 D Ex h IIIC T100°C...T200°C Da  
 II 2 G Ex h ia IIC T5 Gb  
II 2 D Ex h ia IIIC T100°C Db  
II 2 G Ex h mb IIC T5 Gb  
II 2 D Ex mb tb IIIC T100° Db

Meander 1051  
6825 MJ Arnhem  
The Netherlands

- Metallic pump models with no external aluminum (S series, HD Series, G series)
- Conductive plastic pumps equipped with metal muffler (S series, PB Series)
- ATEX pump models equipped with ATEX rated pulse output kit or solenoid kit

➤ See "ATEX Details" page in user's manual for more information  
➤ See "Safety Information" page for conditions of safe use

DATE/APPROVAL/TITLE:  
30 DEC 2019

  
David Roseberry, Director of Engineering