

Job: _____

Item: _____

Quantity: _____

Dunnage Racks -- 6000 Series

APPLICATION:

- All welded all aluminum design is great for keeping product organized and off the floor.

MATERIAL:

- Framework is constructed of 1½" x 1½" x .070" wall tubing.
- The legs are sealed with plastic caps.

GUARANTEE:

- One-Year Guarantee against material defects and workmanship.
- Lifetime Guarantee against rust and corrosion.

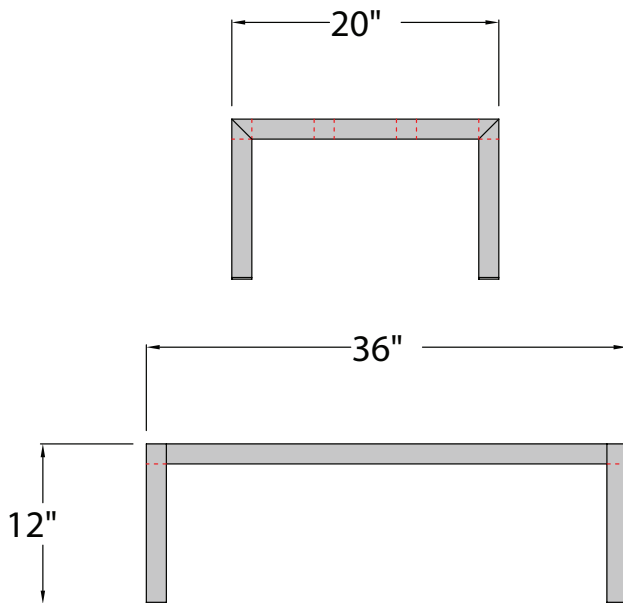

Model No.	# of Laterals	Weight Capacity	Size D-H-L	Ship Lbs.
6017	4	2000 lbs.	20" x 8" x 36"	8
6018	4	2000 lbs.	20" x 8" x 48"	10
6019	4	1500 lbs.	20" x 8" x 60"	13
6004	4	2000 lbs.	20" x 12" x 36"	9
6005	4	2000 lbs.	20" x 12" x 48"	11
6006	4	1500 lbs.	20" x 12" x 60"	14
6014	5	2000 lbs.	24" x 8" x 36"	9
6015	5	2000 lbs.	24" x 8" x 48"	11
6016	5	1500 lbs.	24" x 8" x 60"	14
6008	5	2000 lbs.	24" x 12" x 36"	10
6009	5	2000 lbs.	24" x 12" x 48"	12
6010	5	1500 lbs.	24" x 12" x 60"	15

This information is for general sales and engineering use only. New Age Industrial reserves the right to modify or make changes at any time without notice to materials and specifications.



Distributed by: