



# INSTALLATION DATA

## 4350 SERIES

### COMMERCIAL THERMOSTAT BJ UNI-KIT®

#### DESCRIPTION

The Robertshaw® 4350 Series Commercial Thermostat Uni-Kit® is designed specifically for heavy-duty commercial oven and griddle applications. The High-Temperature thermostats with steel bulb and capillary are supplied in these kits.

The thermostat can be mounted in any of the four manifold positions. Rear housing may be rotated as required. Plugs are included with models having four-position outlet tapping.

Four-position dial, stem length adaptor, and chrome bezel are included.

These kits will replace model BJ and BJWA commercial thermostats. Separate kits are available for oven and griddle applications. Kits will also replace earlier Uni-Line models.

#### INSTALLATION INSTRUCTIONS



**CAUTION**

THIS DEVICE SHOULD BE INSTALLED BY A QUALIFIED PERSON WITH DUE REGARD FOR SAFETY AS IMPROPER INSTALLATION COULD RESULT IN A HAZARDOUS CONDITION.

#### ROTATION OF REAR HOUSING

In many applications, rotation or repositioning of the rear housing is not required. If the rear housing on the replacement control is in the desired position proceed to fittings and plugs.

For applications requiring a change in the housing position, proceed as follows:

1. Remove pilot fitting if installed in control.
2. Remove four hex head bolts on rear of control while applying pressure to hold rear housing against main control body housing. (See illustration at right).
3. Rotate rear housing to desired position.
4. Replace and tighten the four hex head bolts.

**NOTE:** Rotation of the rear housing will also change calibration.

Recalibration of the control after changing rear housing position is easily done at room temperature. View the control from the front using a screwdriver, push in the calibration screw in the center of the gas cock plug. Turn this screw 1/4 turn in the same direction the housing was rotated (viewed from the front). See illustration at right. If housing was rotated 1/4 turn to the side position, the calibration screw must also be turned 1/4 turn in the same direction as the housing was rotated.

#### FITTINGS AND PLUGS

Install plugs into outlets not required and assemble pilot fitting or plug into pilot outlet. Use a small amount of thread compound on each plug and fitting.

#### UNCOIL DIASTAT

**NOTE:** Diastat is liquid filled and sharp bends are to be avoided.

The recommended method to uncoil the diastat is as follows:

Insert a round screwdriver shaft through the center of the diastat coil. Push outward or away from control body to uncoil the diastat smoothly. This method will prevent twisting or crimping.

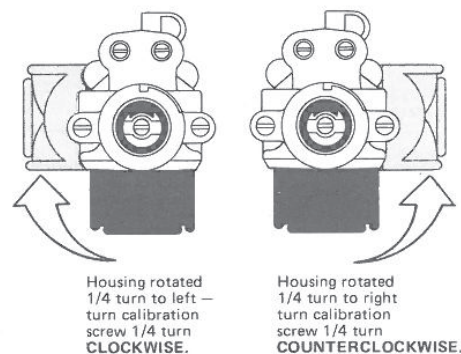
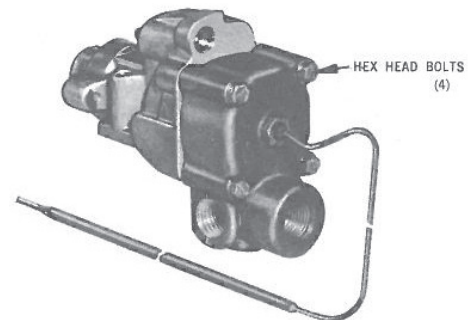
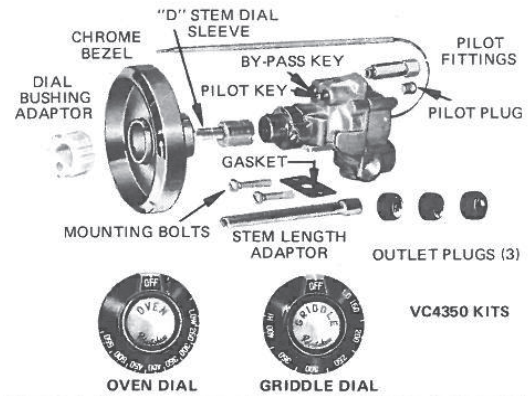

#### MOUNTING

Mount control on manifold using new flange nipple gasket and mounting bolts.

Connect outlet and pilot lines as required for the application.

Attach the sensing bulb into its proper location. Again use caution not to twist or crimp the capillary tube.

## DIAL ASSEMBLY

Insert "D" stem dial sleeve into front of control and snap in place.

The dial bushing adapts the dial to any of the four control mounting positions. Assemble bushing into dial as follows.

Note stem flat position of dial sleeve. Hold dial with "OFF" position at the top and press dial bushing into back of dial so that "D" opening in bushing will match position of stem flat on dial sleeve. See illustration of bushing assembly at right.

If it is necessary to reposition bushing after it is pressed into dial, push out metal-insert on front of dial with small screwdriver. This will allow bushing to be pushed out the back of the dial.

When additional stem length is required, use the stem length adaptors as follows:

1. Place adaptor on "D" stem and place dial on adaptor.
2. To determine correct adaptor length measure distance from back of dial edge to front of panel. Cut this amount from small end of adaptor.
3. If a tighter dial fit is desired spread the end of the "D" stem and stem length adaptor slightly.

## BEZEL INSTALLATION

Bezel and sleeve are installed by sliding center sleeve over dial guide on the front of the control.

If standard sleeve is too short, remove from bezel. Use pliers to apply light pressure and squeeze the adaptor slightly to disengage locking tabs. Install correct length sleeve in bezel.

Bezel index position can be changed to match manifold mounting position of control. Snap sleeve out of bezel as described above, rotate to required position, end snap into bezel.

## OPERATING INSTRUCTIONS

### ADJUSTMENTS

To adjust pilot: (on many applications the pilot is plugged and adjustment is located on safety valve or manifold.)

1. Push dial inward, turn to 300° mark and light the burner.
2. Remove dial. Dial is keyed into place - do not twist or turn it. Grasp the dial at the outer edge and pull straight out.
3. With a screwdriver, turn Pilot Adjusting Key counterclockwise to increase the flame, clockwise to decrease it, until the flame is approximately 3/4" long.
4. Replace dial, turning clockwise until it locks in the "Off" position.

To Adjust By-Pass Flame: (Minimum burner flame)

When the unit reaches the temperature at which the dial is set, the control cuts down the flow of gas to the amount required to keep the unit at that temperature. Always, however, the control must by-pass enough gas to keep the entire burner lit: To maintain this minimum flame, the by-pass must be set carefully and accurately as follows:

1. Light the burner, then turn dial to "High".
2. After 5 minutes, turn dial clockwise to point slightly beyond first mark on dial.
3. Remove dial.

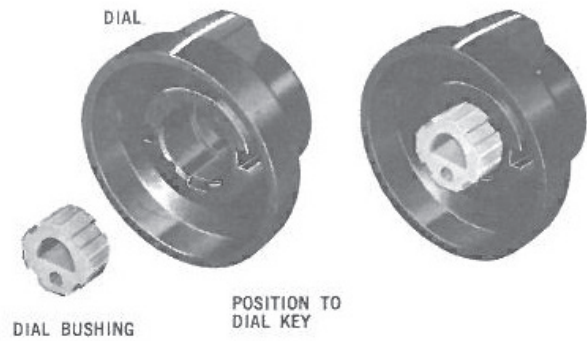

4. With a screwdriver, turn by-pass adjusting key counterclockwise to increase the flame, clockwise to decrease it, until there is a flame approximately 1/8" high over the entire burner.
5. Replace dial, turning clockwise until it locks in the "Off" position.

## SERVICE INSTRUCTIONS

To recalibrate control:

This control is a precision instrument. It is carefully calibrated at the factory that is, it is adjusted so that dial settings match actual temperatures. Field recalibration is seldom necessary, and should not be resorted to unless considerable experience with cooking results definitely proves that the control is not maintaining the temperatures to which the dial is set.

Recalibration should not be undertaken, however, until the by-pass flame has been adjusted.

To check temperatures when recalibrating, use a test instrument or a reliable mercury thermometer. Place the thermocouple lead of test instrument in the middle of the oven. Use surface type thermocouple lead for griddles.

If Recalibration is required, use the following procedure:

1. Set dial to 400° mark and light oven burner. (300° for griddles)
2. After burner has been on about 15 minutes, check temperature. Oven door should be open for as short a time as possible. Use a flashlight, if necessary, to see the thermometer reading clearly.
3. Continue to check temperature, at 5-minute intervals, until two successive readings are within 5 degrees of each other.

If recalibration is required, the additional steps to be taken are these:

4. Remove dial assembly with "D" type stem.
5. Push calibration stem (in center of gas cock stem) inward with screwdriver, while holding calibration stem firmly in, turn slot clockwise to obtain a lower temperature or counterclockwise for a higher temperature. Each mark on retainer represents 25 degrees. Replace "D" type stem with dial.
6. Check temperature again, as instructed in (2) and (3).



Customer Service Telephone 1.800.304.6563  
Customer Service Facsimile 1.800.426.0804  
HVACCustomerService@robertshaw.com

For Technical Service  
Telephone 1.800.445.8299  
Facsimile 1.630.260.7294  
TechnicalService@robertshaw.com

Robertshaw®, Ranco®, Paragon® and Uni-Line® are trademarks of Robertshaw, its subsidiaries and/or affiliated companies. All other brands mentioned may be the trademarks of their respective owners.

www.uni-line.com  
www.robertshaw.com  
©2014 Robertshaw  
08/14 -1-110 RevB