

HAZARDOUS LOCATION PNEUMATIC VACUUMS

ATEX Certified For Hazardous Locations

INCLUDES MODELS: N301BCATEX, N301BCXATEX, N301DCATEX, N551BCATEX, N551BCXATEX, N551DCATEX, N552BCATEX, N552BCXATEX

OPERATING MANUAL



GUARDAIR®

UNITS COVERED BY THIS MANUAL

30 GALLON CAPACITY

N301BCATEX
N301BCXATEX
N301DCATEX

55 GALLON CAPACITY

N551BCATEX
N551BCXATEX
N551DCATEX
N552BCATEX
N552BCXATEX

ATEX CERTIFICATION

Currently no US standards exist to certify non-electrically powered equipment, such as pneumatic vacuums, for safe use in hazardous locations. However, Europe has such standards and they are known as **ATEX Directives**. Guardair engaged SIRA Test & Certification, Ltd, a United Kingdom-based, nationally recognized testing laboratory, to certify that the above Guardair Hazardous Location Pneumatic Vacuums meet the applicable ATEX Directives.

After a comprehensive evaluation, SIRA Test & Certification certified the above models have the following rating:

ATEX II2 GD c IIC T6

This ATEX rating is equivalent to the following National Fire Protection Association (NFPA) 70: National Electric Code (NEC) rating:

Class I Division 1* Groups A, B, C, D T6
Class II Division 1 Groups E, F, G T6
Class III

*Zone 1 only

PARTS INCLUDED WITH UNIT

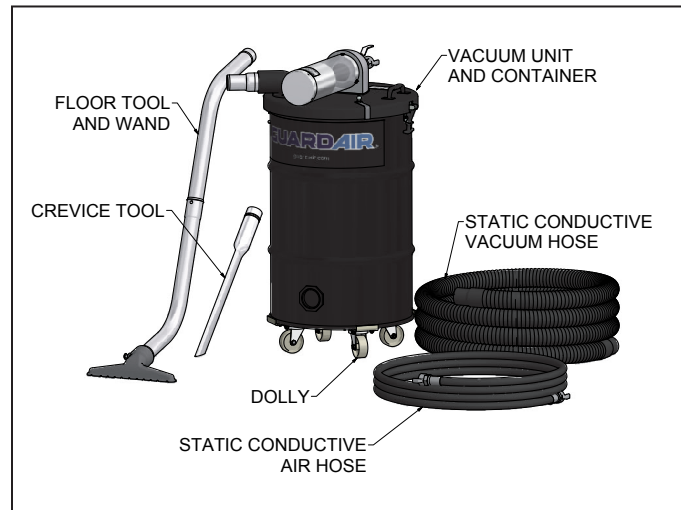

OPTIONAL EQUIPMENT

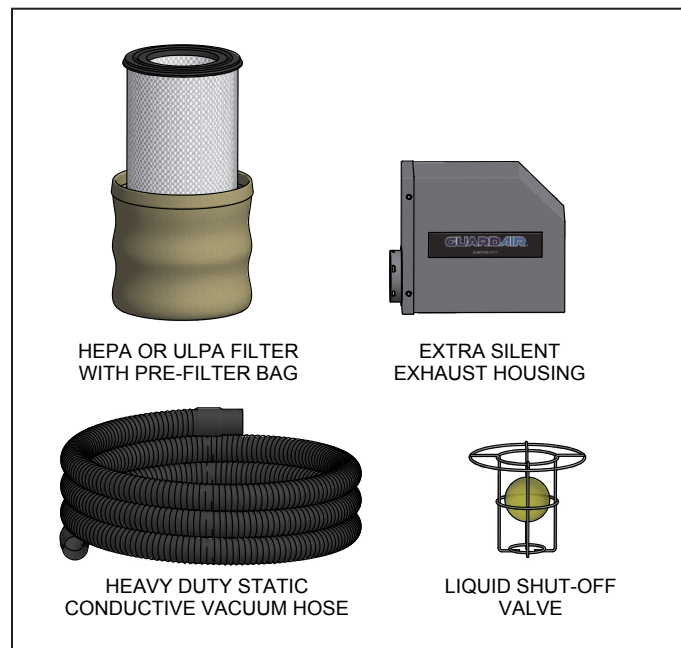

SAFETY FEATURES

Guardair Hazardous Location Pneumatic Vacuums are designed to eliminate and dissipate the buildup of static charges. The following safety features ensure the components of the vacuum unit are electrically connected and that the entire unit can easily be grounded.



All vacuum parts and accessories are constructed of metal (electrically conductive), or with plastic infused with conductive additives. Painted parts are coated with electrically conductive paint.

The filter is surrounded with conductive steel mesh. Steel springs hold the filter to the cover and provide electrical continuity.

Metal-to-metal contact between the cover and the container is provided through the braided grounding strap.

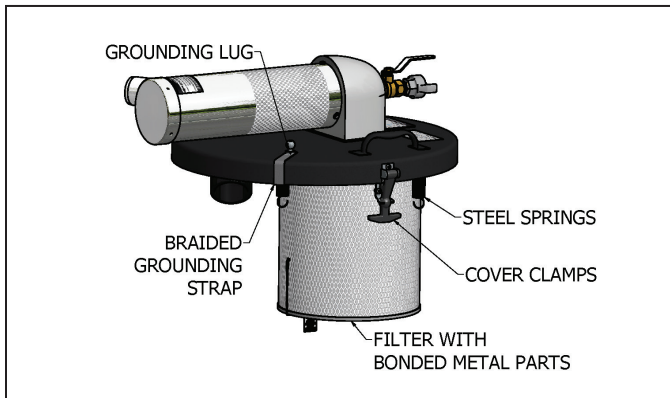

Static conductive vacuum hose eliminates the generation of static electricity caused by material passing through the vacuum hose.

The grounding lug on the cover provides one means to connect the vacuum via wire or cable to electrical ground. Static conductive air supply hose provides another means to ground the vacuum. The steel drum dolly with steel wheels provides a third means for grounding the unit if the floor on which the unit rests is in turn electrically grounded.

See **GROUNDING THE VACUUM** on Page 4 for more information on proper grounding procedures.

COMPRESSED AIR SUPPLY

Adequate compressed air supply is essential to the proper performance of your Guardair vacuum. Compressed air requirements are as follows:

2B-Series Models	110 cfm
N552BCATEX	
N552BCXATEX	
B-Series Models	68 cfm
N301BCATEX	
N301BCXATEX	
N551BCATEX	
N551BCXATEX	
D-Series Models	47 cfm
N301DCATEX	
N551DCATEX	

Recommended operating pressure for all Guardair vacuums is 100 psi, although all models will operate at lower pressures with a corresponding reduction in performance. Use of 3/4" ID air supply hose with 3/4" Chicago style connectors is recommended to ensure adequate air flow is delivered to the vacuum.

NOTE: Make all compressed air connections with the compressed air source turned off. Disconnect compressed air connections only after the compressed air supply has been turned off and the air supply hose vented by opening the valve on the vacuum. NEVER disconnect a pressurized compressed air hose.

GROUNDING THE VACUUM

In order to operate safely in approved hazardous locations, the vacuum must be properly grounded during operation. Proper grounding can be achieved in one of three ways:



Option One is through use of the static conductive air supply hose. This option utilizes a static conductive air supply hose to connect the vacuum to a compressed air distribution system that is in turn grounded. Only use this method if the compressed air distribution system has been verified to be electrically grounded.



Option Two is through use of the grounding lug. This option utilizes a direct electrical connection from the grounding lug on the vacuum cover to a verified electrical ground (i.e. electrical cabinet, ground rod, water pipe, etc.). The connection from the grounding lug to electrical ground can be achieved via wire, cable, or a ground strap with clamps.



Option Three is to operate the vacuum on an electrically grounded surface. This option provides conductivity from the vacuum directly to an electrically grounded surface (i.e. steel plate, concrete ground level floor, etc.). The container of the vacuum can rest on the grounded surface directly, or on the dolly. Both the container and the dolly, including wheels, are constructed from conductive material (steel). Only use this method if the surface is electrically grounded, and only when a continuous electrical connection between the vacuum and the surface can be maintained.

NOTE: Employing multiple, redundant grounding options is always good operating practice.

FOR ALL GROUNDING OPTIONS, IT IS RESPONSIBILITY OF THE END-USER TO ENSURE PROPER CONNECTION TO, AND THE ELECTRICAL INTEGRITY OF, THE GROUND.

SET-UP AND OPERATION

Prior to operating the vacuum, inspect the unit and replace worn or broken components. Use only original Guardair equipment as replacement parts.



Inspect the bottom side of the vacuum head cover to ensure the filter and/or liquid shut-off valve is securely in place by use of the 3 supplied springs. The springs secure the filter in place, and electrically connect the filter to the vacuum.

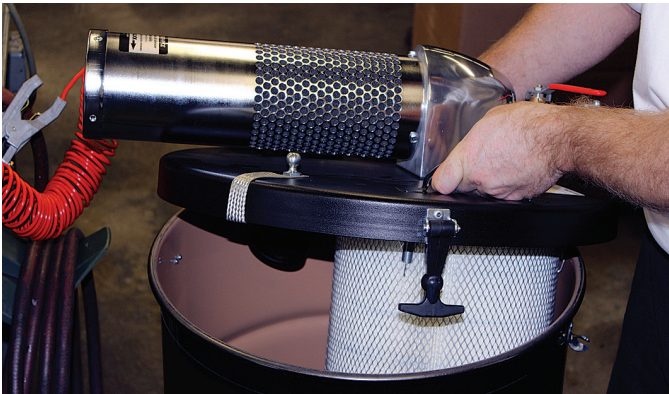

Place the vacuum head on the drum and clamp the lid to the container. Ensure the cover clamps are locked in place.



Connect the vacuum hose and desired accessories to the vacuum.

Make sure the vacuum has been grounded via one or more of the options described in **GROUNDING THE VACUUM** on Page 4.



Make sure the ball valve on the vacuum is turned off.

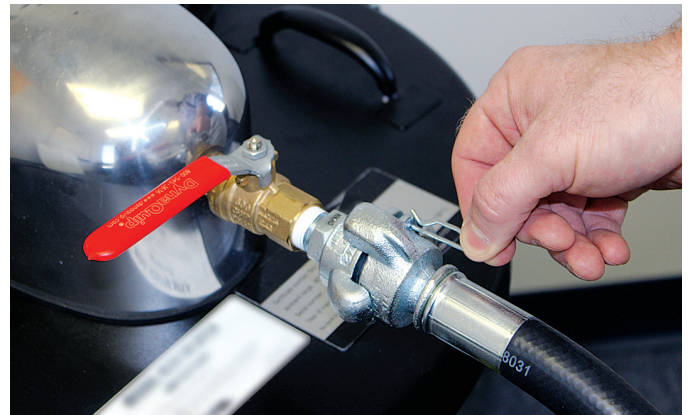

Connect the air supply hose to the vacuum using Chicago style connectors and install the safety clips.

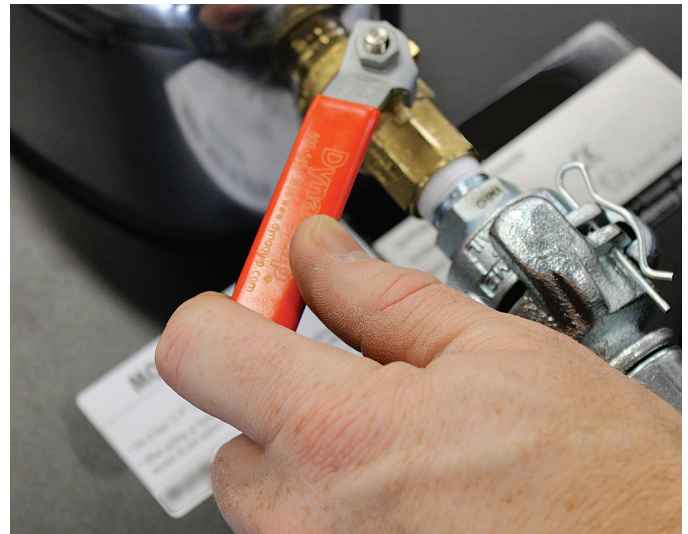

Turn on the compressed air supply and open the ball valve on the vacuum to operate the unit.

NOTE: Take time to understand the specific nature of the material to be vacuumed and take all necessary precautions specific to that material. For example, allow proper charge relaxation time prior to removing the vacuum lid.

MAINTENANCE

Check the internal filter periodically. Ensuring maximum performance means cleaning the filter when it becomes dirty and/or clogged. To clean the filter, detach the filter from the cover by following the steps below:



Unclip the three springs that secure the filter to the vacuum cover.



Lift filter out from base.



To clean, shake out filter, or blow off with a safety airgun.

Damaged, ripped, or torn filters should be replaced immediately. Over time, even filters that have been cleaned regularly lose their effectiveness as the pores in the filter media fills up. Therefore, regular filter replacement should be a part of an effective maintenance plan. Follow the same steps as above to change out the filter. Periodically check the exhaust silencer. While the exhaust silencer does not provide a filtering function, dust may collect within the silencer media especially when filter maintenance has been neglected over time.

Clean or replace the exhaust silencer by following the steps below:



Remove the three screws which attach the exhaust housing to the venturi box.



Slide the foam insert out of the exhaust housing. Shake out the foam insert, or replace if frayed or torn.



Replace the cover gasket should it become worn, frayed, or ineffective.

Replacement filters, foam inserts, and cover gaskets are available directly from Guardair.

WET VACUUM OPTION



To convert from a dry vac to a wet vac, remove filter and replace with the liquid shut-off assembly as shown above.

TWO YEAR LIMITED WARRANTY

Guardair Vacuum Products Division of Guardair Corporation ("Guardair") warrants its Guardair HAZARDOUS LOCATION PNEUMATIC VACUUM to be free from defects in materials and workmanship for a period of two years from purchase date, except as provided below. Guardair will, at its option, repair or replace with comparable product, any product, part, or component, which fails under normal use as a result of such defect.

This Warranty does not apply to damage caused by the carrier; normal wear and tear; deterioration due to solvents, corrosives, environmental conditions or harsh vacuumed material; soiling, saturation, or perforation of filters or exhaust silencers; consumable components; modifications to the product; attachments to the product not carried by Guardair; or any product not installed, used, or maintained in accordance with the foregoing and other published Guardair instructions and warnings. Consumables including attachments, vacuum hose, filters, exhaust silencers, and gaskets are warranted for a period of 90 days against defects in materials and workmanship, are subject to the same exclusions noted above.

This Warranty covers the original purchase of a new Guardair HAZARDOUS LOCATION PNEUMATIC VACUUM for normal industrial or commercial use, and only when installed and used as specified and in accordance with published operating instructions, and within all applicable regulatory rules, limits, and guidelines.

THIS WARRANTY IS THE ONLY WARRANTY MADE BY GUARDAIR FOR THIS PRODUCT, AND ALL OTHER WARRANTIES, EXPRESS OR IMPLIED, INCLUDING BUT NOT LIMITED TO THE IMPLIED WARRANTIES OF MERCHANTABILITY AND FITNESS FOR A PARTICULAR PURPOSE ARE DISCLAIMED.

Guardair's sole obligation and the purchaser's exclusive remedy under this Warranty shall be limited to the repair or replacement, at the sole discretion of Guardair, of product or components. In no

event shall Guardair be responsible for special, consequential or incidental damages arising out of a claim for defective product or failure of this Warranty. All labor and material costs of repair or replacement under this Warranty shall be the responsibility of Guardair. Shipping costs to and from the purchaser associated with repair or replacement under this Warranty shall be the responsibility of the purchaser.

To obtain service under this Warranty, within 30 days of the discovery of the defect, the purchaser must contact the dealer or distributor from whom the product was purchased, or contact Guardair at the address shown below. The purchaser must provide a reasonable opportunity for inspection and investigation of the claim, prior to any repairs or alteration to the product. Until the claim is resolved, purchaser must discontinue use of the product if continued use creates or exacerbates problems associated with, or incidental to, the defect.

Proof of purchase must be presented by the purchaser and applicability of the Warranty will be determined by Guardair. Guardair will determine whether to provide repair service, provide replacement parts, or replace the product. Written approval from Guardair must be obtained before any repair service is performed. Any repairs performed by parties other than Guardair or its authorized dealers or distributors will void this Warranty. Before returning any product for repair or replacement to Guardair, a Return Authorization from Guardair must first be obtained.

This Warranty applies only to purchases within, and products used within, the United States and Canada.

QUESTIONS? Contact Guardair with any questions concerning application, operation, and performance of your Guardair vacuum, regardless of the original purchase date.

GUARDAIR[®]
CORPORATION

47 Veterans Drive
Chicopee, MA 01022
Phone (413) 594-4400
Toll Free (800) 482-7324

Fax (413) 594-4884
guardaircorp.com • info@guardaircorp.com

N600A01ATX

