

Catalog Number
Notes
Type

FEATURES & SPECIFICATIONS

INTENDED USE — To be powered by Quantum series emergency units and any battery voltage system between 5VDC and 30VDC output and with adequate wattage capacity. Remote lamp head matches the appearance of the Quantum® ELM2LF, ELM2L, ELM4L, ELM6L series units, as part of an emergency lighting system providing light for the path of egress. **Certain airborne contaminants can diminish the integrity of acrylic and/or polycarbonate.** [Click here for Acrylic-Polycarbonate Compatibility table for suitable uses.](#)

CONSTRUCTION — Compact, low-profile contemporary design, available in white (standard) or black. Engineering-grade thermoplastic housing is impact-resistant, scratch-resistant and corrosion-proof. UV stable resin resists discoloration from natural and man-made light sources. Strong, compact and corrosion-resistant with a UL94V-0 flame rating.

Single or twin heads available.

Fully adjustable lamp heads to meet all aiming requirements.

Universal J-box mounting pattern. Tool-less access for maintenance. **US Patent No. D483,511.**

OPTICS — LED, available in: 1.2W (LP220L) or 3.3W (SP640L) lamps @ 5VDC-20VDC input, and 5.3W (SP1100L) lamps @ 7VDC-30VDC input.

LEDs provide nominal 70 CRI at 5000 K.

INSTALLATION — Wall or Ceiling mount standard. Flexible conduit entry provision on top of the unit. **US Patent No. D483,511.**

LISTINGS — UL damp location listed standard and wet location listed when used with the WPVS accessory, up to -22-104°F(-30 -40°C). Meets UL 924, NFPA 101 (current Life Safety Code). Meets NFPA 70 (NEC), C22.2 CSA. Meets all applicable FCC requirements. Meets NEC and OSHA illumination standards. Meets Mexican standards. Available for sale in California.

WARRANTY — 5-year limited warranty. Complete warranty terms located at: www.acuitybrands.com/support/warranty/terms-and-conditions

NOTE: Actual performance may differ as a result of end-user environment and application.

All values are design or typical values, measured under laboratory conditions at 25 °C.

Specifications subject to change without notice.



LED Thermoplastic Emergency Remote

ELMRE



MOUNTING

All dimensions are inches (centimeters) unless otherwise indicated.

*ELMRE LP220L SGL / T
Specifications*

Length: 6.87 (174)
Depth: 3.53(90)
Height: 4.67(119)
Weight of SGL: 0.75 lbs (0.34kg)
Weight of T: 0.8 lbs (0.36kg)

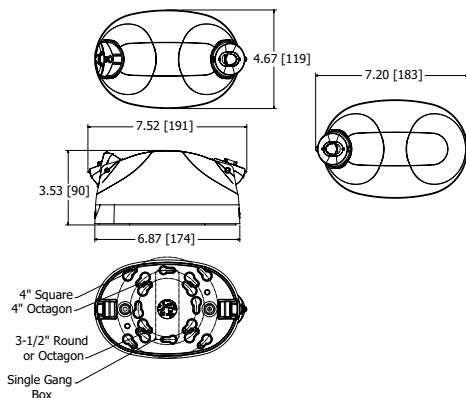

*ELMRE LP220L FXO
Specifications*

Length: 9.22 (23.42)
Depth: 3.10 (7.87)
Height: 4.68 (11.88)
Weight: 1.25lbs (0.57kg)

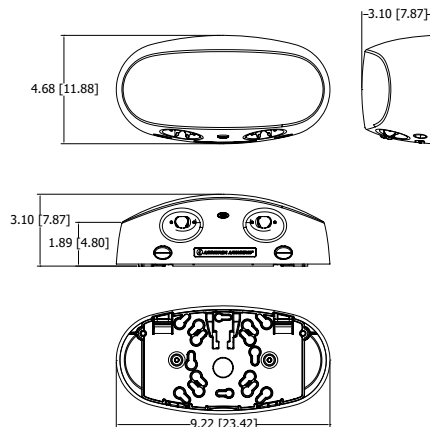

*ELMRE SP640L SGL / T
ELMRE SP1100L SGL / T
Specifications*

Length: 6.87 (174)
Depth: 3.69 (94)
Height: 4.67 (119)
Weight of SP640L SGL: 1.05lbs (0.48kg)
Weight of SP640L T: 1.55lbs (0.70kg)
Weight of SP1100L SGL: 1.2lbs (0.54kg)
Weight of SP1100L T: 1.65lbs (0.75kg)

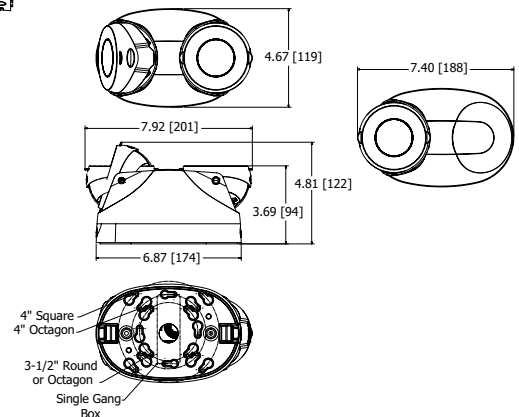

ELMRE Quantum® LED Thermoplastic Emergency Light

ORDERING INFORMATION

For shortest lead times, configure product using **bolded options**.

Example: ELMRE LP220L SGL

Series	Voltage	Lamp Type	Housing Color	Number of lamps	Lamp head type	Options
ELMRE LED thermoplastic emergency remote	(blank) Universal DC voltage	LP220L 110 lumen, 1.2 watt, Linear pattern, 5VDC-20VDC input SP640L 320 lumen, 3.3 watt, Spot pattern, 5VDC-20VDC input SP1100L 550 lumen, 5.3 watt, Spot pattern, 7VDC-30VDC input	(blank) White B Black	(blank) Fixed lamps only SGL Single, aimable T Twin, aimable ¹	FXO Fixed lamps ²	BAA Buy America(n) Act Compliant

Accessories: Order as separate catalog number.

WPVS SML W	White, wet protective vandal shield (must be used for wet location applications). Decreases delivered lumens up to 20%. For black, change W to B. See spec sheet WPVS
ELA WG1	Wireguard, 15" W x 13-1/2" H x 6" D (see spec sheet ELA-WG)

Notes

- For twin (T) remote, multiply lumens and watts by 2.
- FXO only available with LP220L lamp type @ 5VDC-20VDC input. Not available with SGL or T. Includes 2 lamp heads (same appearance as ELM2LF)



BATTERY CAPACITY AND LOADING

Battery Option (LTP Only)	Battery Voltage	Total Capacity 90 Minutes	LP220L (1.2 Watts each) Maximum # Remote Lamps ¹	SP640L (3.3 Watts each) Maximum # Remote Lamps ¹	SP1100L (5.3 Watts each) Maximum # Remote Lamps ¹
ELM2L LTP	9.6V	4.8 watts	2	0	0
ELM2LF LTP	9.6V	4.8 watts	2	0	0
ELM4L LTP	9.6V	11 watts	3	1	NA
ELM4L LTP HO	9.6V	22 watts	12	4	2
ELM4L LTP EHO	12.8V	32 watts	21	7	6
ELM6L LTP	9.6V	11 watts	0	0	0
ELM6L LTP HO	9.6V	22 watts	9	3	2
ELM6L LTP EHO	12.8V	32 watts	17	6	4
ELM6L LLH LTP	9.6V	11 watts	9	3	2
ELM6L LLH LTP HO	9.6V	22 watts	18	6	4
ELM6L LLH LTP EHO	12.8V	32 watts	26	9	6

Notes

- These are in addition to the lamp heads on the product.