

**SF-2400/SF-2450**

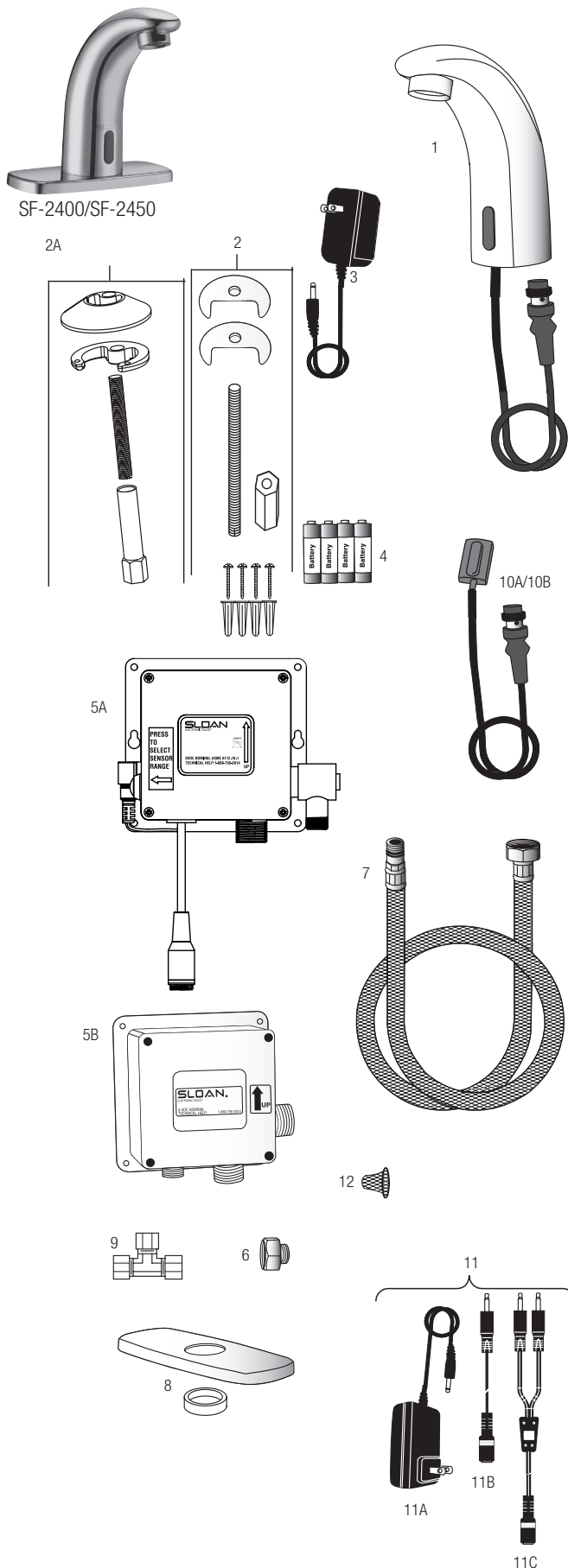

**PARTS LIST—SF-2400/SF-2450**

Item No.	Code No.	Part No.	Description
1.	—	—	Pedestal Faucet Assembly w/Outlet (Models SF-2400/SF-2450/)
2.	<b>0362004</b>	SFP-4	Mounting Hardware Kit, (Models SF-2100/SF-2150/SF-2400/SF-2450) (pre-3/2010)
2A.	—	SFP-44-A	Mounting Hardware Kit, (Models SF-2100/SF-2150/SF-2400/SF-2450) (Post 3/2010)
	—	SFP-5	Screws and Anchors for Control Module
3.	<b>0362006</b>	SFP-6	110 VAC/6 VDC Plug-In Adapter (US)
4.	—	—	Batteries-AA size (4)
5A.	<b>0362040</b>	SFP-40-A	Control Module with Adjustable Button (6 pin connector)
5B.	<b>0362008</b>	SFP-8	Control Module (Old Style 4 pin connector)*
6.	<b>0362045</b>	SFP-45-A	Inlet adapter – 1/2" NPSM to 3/8" Compression Connection (not supplied with most international models)
7.	<b>0362010</b>	SFP-10	Flex Hose, Control Module to Spout
8.	<b>0362011</b>	SFP-11	Trim Plate w/ Spacer (not supplied with most international models)
9.	<b>3365461</b>	ETF-617-A	3/8" Bak-Chek® Tee Compression Fitting
10A.	<b>0362041</b>	SFP-41-A	Sensor Assembly (6 pin connector)
10B.	<b>0362034</b>	SFP-34	Sensor Assembly (Old Style 4 pin connector)*

\* IMPORTANT: Sloan added the range adjustment feature in August 2008 for faucets made prior to August 2008 use the following replacement parts: SFP-34 and SFP-8

**NOT SHOWN SEPARATELY**

—	<b>0335029</b>	EAF-51	0.35 gpm (1.3 Lpm) spray head
—	<b>0335012</b>	EAF-15	0.5 gpm (1.9 Lpm) vandal resistant spray head
—	<b>3362000</b>	SFP-1000	0.35 gpm (1.3 Lpm) vandal resistant spray head
—	<b>0362013</b>	SFP-13	0.5 gpm (1.9 Lpm) Spray head
—	<b>0362023</b>	SFP-23	2.2 gpm (8.3 Lpm) Aerator
—	<b>0362024</b>	SFP-24	2.2 gpm (8.3 Lpm) vandal resistant aerator
—	<b>0362020</b>	SFP-26	220 VAC/6 VDC Plug-In Adapter (ASIA)
—	<b>0362025</b>	SFP-25	220 VAC/6 VDC Plug-In Adapter (EURO)
—	<b>0362026</b>	SFP-20	220 VAC/6 VDC Plug-In Adapter (UK)
—	<b>3362022</b>	SFP-22	8" Trim Plate

**ACCESSORIES**

11.	<b>0362035</b>	SFP-35-A	100-240 VAC/6 VDC Gang Adapter Kit, includes 11A, 11B and 11C
11A.	<b>0362016</b>	SFP-36-A	100-240 VAC/6 VDC Plug-In Adapter
11B.	<b>0362018</b>	SFP-38	Cable Splitter, 51"/1300 mm (5 included in kit)
11C.	<b>0362017</b>	SFP-37	Cable Extension, 51"/1300 mm

**REPAIR PARTS**

12.	<b>0362015</b>	SFP-15	Strainer (located in water inlet of control module)
-----	----------------	--------	---

— in Item No. column = Not shown in illustration  
 — in Code No. and Part No. column = Not sold separately

---

**SF-2400/SF-2450**

---

**TROUBLESHOOTING GUIDE**

---

**1. Faucet delivers water in an uncontrolled manner.**

A. Faucet is not working properly. Contact Sloan Technical Support.

**2. Faucet DOES NOT deliver any water when sensor is activated.**

**INDICATOR: Solenoid valve produces an audible “CLICK.”**

- A. Water supply stop(s) closed. Open water supply stop(s).
- B. Water strainer in control module is clogged. Close supply stops and remove water inlet line at control module. Remove, clean and reinstall strainer and water inlet line. Replace strainer if required.

**INDICATOR: Solenoid valve DOES NOT produce an audible “CLICK.”**

- A. Batteries low (battery powered models). Replace batteries.
- B. Power failure (adapter powered models). Check power supply.

**3. Faucet delivers only a slow flow or dribble when sensor is activated.**

- A. Water supply stop(s) are partially closed. Completely open water supply stop(s).
- B. Water strainer in control module is clogged. Close supply stops and remove water inlet line at control module. Remove, clean and reinstall strainer and water inlet line. Replace strainer if required.
- C. Aerator is clogged. Remove, clean, and reinstall aerator. Replace aerator if required.
- D. Faucet is not working properly. Contact Sloan Technical Support.

**4. Faucet DOES NOT stop delivering water or continues to drip after user is no longer detected.**

A. Faucet is not working properly. Contact Sloan Technical Support.

**5. The water temperature is too hot or too cold on a faucet connected to hot and cold supply lines.**

A. Supply Stops are not adjusted properly. Adjust supply stops.

**CARE AND CLEANING INSTRUCTIONS**

---

**DO NOT USE** abrasive or chemical cleaners (including chlorine bleach) to clean faucet that may dull the luster and attack the chrome or special decorative finishes. Use **ONLY** mild soap and water, then wipe dry with clean cloth or towel.

While cleaning the bathroom tile, protect the faucet from any splattering of cleaner. Acids and cleaning fluids will discolor or remove chrome plating.

**When assistance is required, please contact Sloan Technical Support at: 1-888-SLOAN-14 (1-888-756-2614).**