

# FORK MOUNTED RUG-RAM - CRF-144

APPROX WEIGHT: 436.85 lbs.  
 DOES NOT INCLUDE WEIGHT OF POWER OR PACKAGING!!!

\*\*\* ANY ADDITIONS, DELETIONS, OR OMISSIONS MUST BE CORRECTED ON THIS DRAWING AS THIS DRAWING WILL BE CONSIDERED ALL INCLUSIVE \*\*\*

ALL GRAPHICS PROVIDED ARE FOR REFERENCE ONLY. IF CERTAIN DIMENSIONS ARE CRITICAL PLEASE VERIFY THOSE DIMENSIONS WITH YOUR SALESPERSON

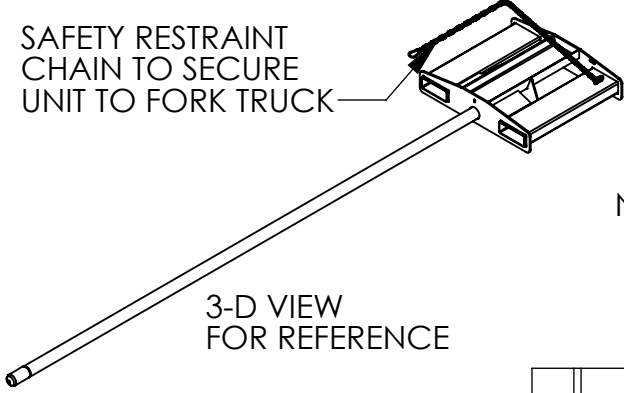
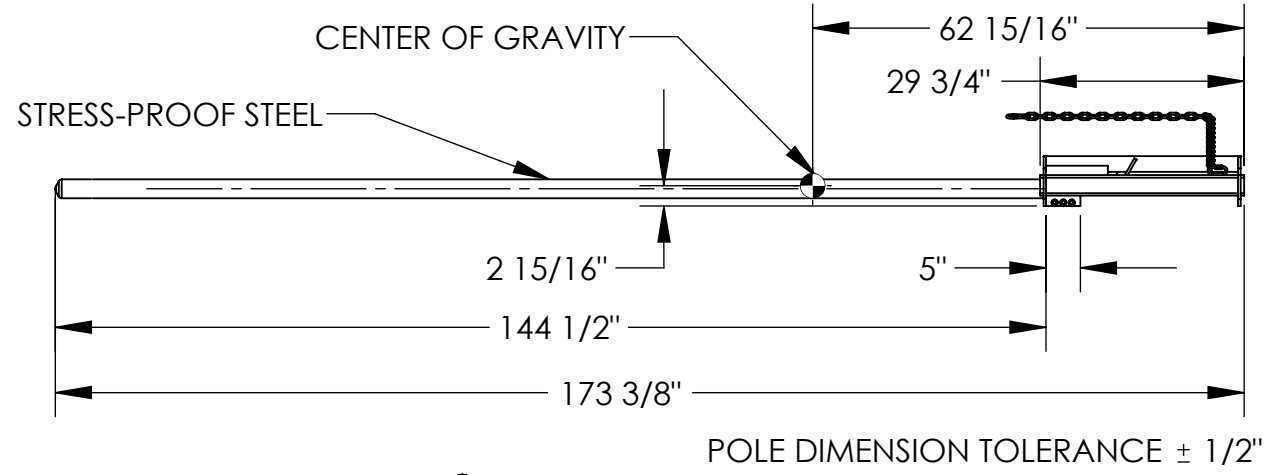
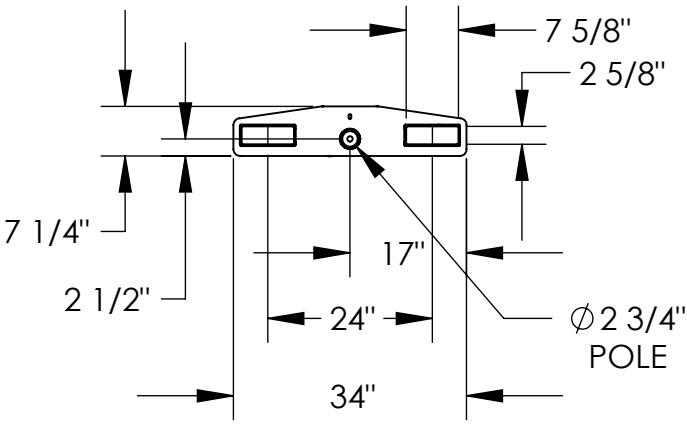

SAFETY RESTRAINT  
 CHAIN TO SECURE  
 UNIT TO FORK TRUCK

3-D VIEW  
 FOR REFERENCE

NOTE: NEVER EXCEED LOAD CENTER RATING PER  
 FORK TRUCK MANUFACTURER'S GUIDELINES.  
 DO NOT USE THIS FORK TRUCK ATTACHMENT  
 IF LOAD WILL EXCEED FORK TRUCK  
 MANUFACTURER'S LOAD CENTER RATING.

HORIZONTAL CENTER OF GRAVITY: 62 15/16"  
 VERTICAL CENTER OF GRAVITY: 2 15/16"  
 LOST LOAD: 437 LBS. (APPROX.)  
 MINIMUM EFFECTIVE THICKNESS= LESS THAN 1"

## STANDARD FEATURES

- MODEL NUMBER: CRF-144
- CAPACITY: 1,800 LBS. UNIFORM CAPACITY
- POLE LENGTH: 144 1/2"
- OVERALL LENGTH: 173 3/8"
- POLE DIAMETER: 2 3/4"
- FORK POCKETS ARE 7 5/8" W x 2 5/8" H
- USABLE ON 24" FORK CENTERS
- WITH SAFETY CHAIN TO SECURE TO THE UNIT TO THE MAST OF THE FORK TRUCK
- DURABLE LIQUID PAINT
- BLUE FINISH ON FRAME

## SPECIAL FEATURES

NONE

<b>A P P R O V A L</b>	I, THE UNDERSIGNED, AGREE THAT THE PRODUCT AS REPRESENTED SATISFIES DESIGN AND DIMENSION REQUIREMENTS. I ALSO ACKNOWLEDGE MY DUTY TO CONFIRM PRODUCT AND INSTALLATION COMPLIANCE WITH ALL APPLICABLE FEDERAL, STATE AND LOCAL REGULATIONS AND STANDARDS.	
	<b>UNITS REQUIRING APPROVAL DRAWINGS OR MODIFIED ARE NON-RETURNABLE</b>	
	[ ] As drawn	[ ] As marked
Signed: _____		Date: _____
Printed Name: _____		
<i>LEAD TIME WILL START UPON RECEIPT OF SIGNED APPROVAL DRAWING</i>		

DISTRIBUTOR'S NAME:		P.O.#
<b>VESTIL MANUFACTURING</b>		X
		W.O.#
DRAWN BY: BJW	DATE: 1/12/2008	SALES: X
REFERENCE: X	SCALE: 1:28	FILE NAME:
QUOTED LEAD TIME: X	QUOTE # X	08-007-158