

► Models 504WB and 506WB

Vibratone® Bell Assemblies



Vibratone® Bell Models 504WB and 506WB are completely assembled and include the gong, vibrating AC mechanism, and the gasketed back box. These assemblies feature heavy duty, industrial grade housings and powder-coat paint treatments for added durability and performance.

Vibratone gongs are tempered to produce superior output and long lasting durability.

Both models contain internal terminal blocks which simplifies installation. This method also allows for an uninterrupted, single run of wiring.

FEATURES

- Available in 120VAC
- Four-inch or six-inch gong
- Four-inch gong produces 98 dBa @ 10' (107 dBa @ 1m)
- Six-inch gong produces 100 dBa @ 10' (109 dBa @ 1m)
- Type 3R enclosure
- UL and cUL Listed, CSA Certified and FM Approved

MODEL	VOLTAGE	OPERATING CURRENT	DECIBELS	
			10'	1M
504WB-120	120VAC	0.08 amps	98	107
506WB-120	120VAC	0.08 amps	100	109

Vibratone® Bell Assemblies (504WB/506WB)

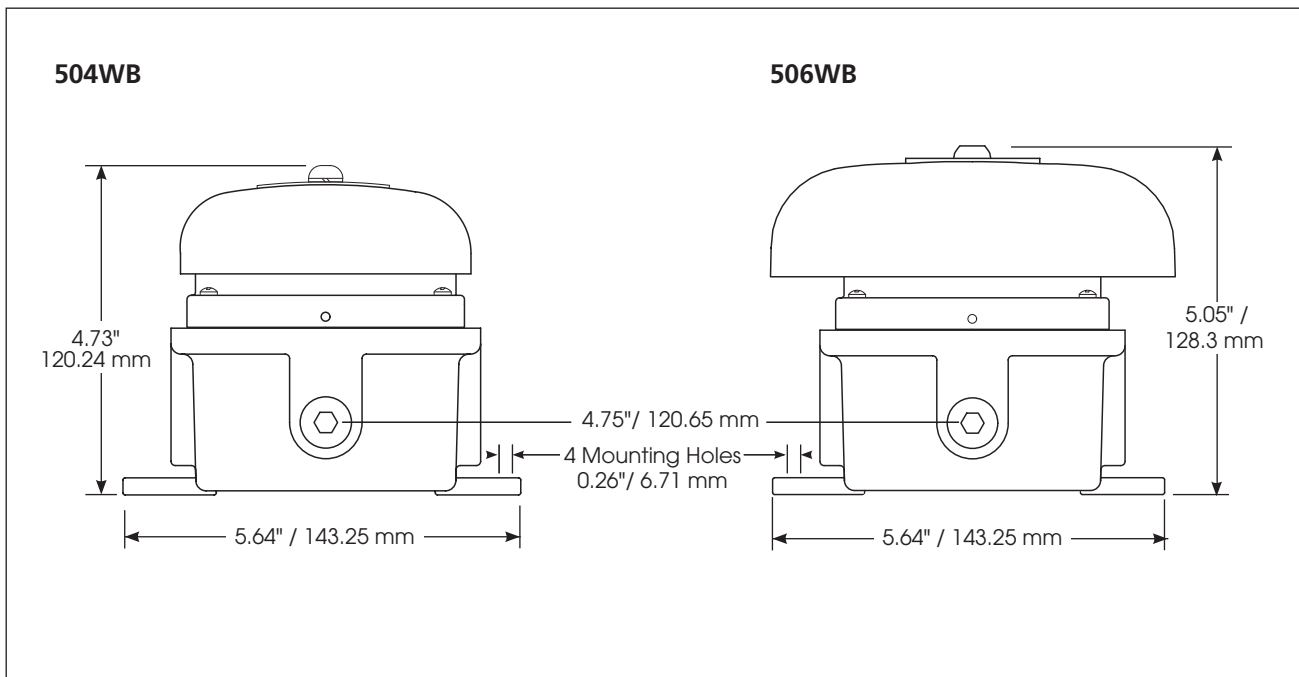

SPECIFICATIONS

Operating Temperature:	-31°F to 150°F	-35°C to 66°C
Net Weight:		
Model 504	1.05 lbs	0.48 kg
Model 506	2.5 lbs	1.13 kg
Shipping Weight:		
Model 504	1.65 lbs	0.75 kg
Model 506	3.0 lbs	1.36 kg
Depth:		
Model 504	4.73"	120.24 mm
Model 506	5.05"	128.3 mm
Width:		
Model 504	5.64"	143.25 mm
Model 506	6.02"	152.9 mm
Height:		
Model 504	5.64"	143.25 mm
Model 506	6.02"	152.9 mm

HOW TO ORDER

Specify Model:
504WB-120 – Vibrating bell, 4", 120VAC weatherproof back box
506WB-120 – Vibrating bell, 6", 120VAC weatherproof back box