

PARTS LIST				
ITEM	QTY	PART NUMBER	DESCRIPTION	
2	1	300G	3" COUPLING GASKET, EPDM	
3	3	300K	CAM ARM	
4	3	300P	CAM ARM PIN	
5	1	303B200AX	3" FEMALE COUPLER X 2" MALE ADAPTER	

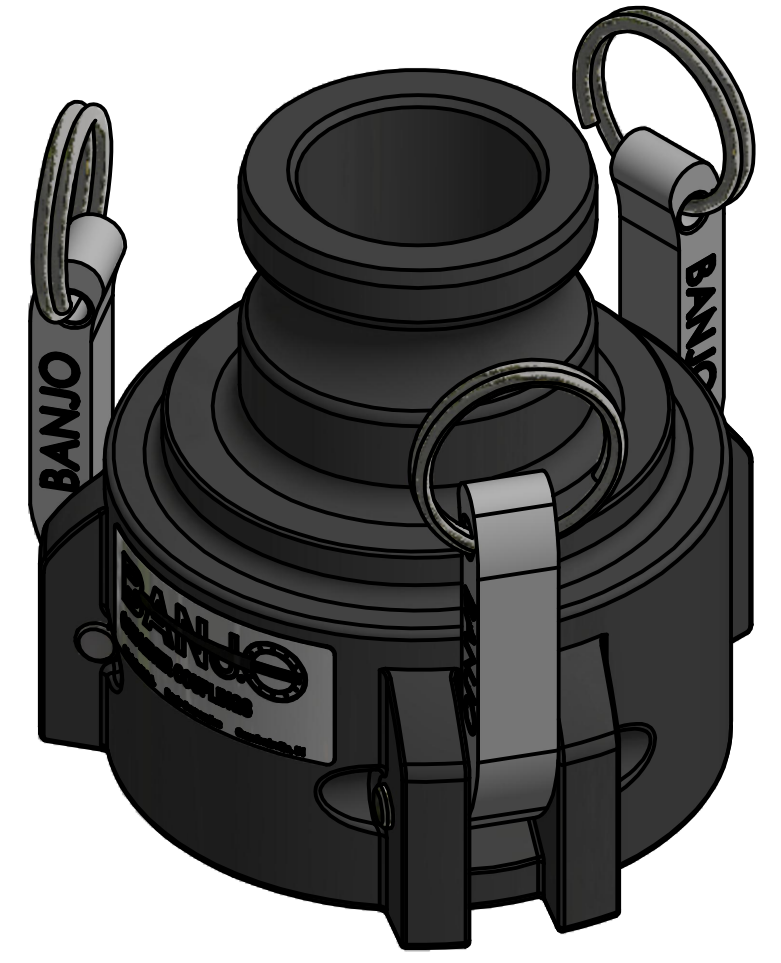
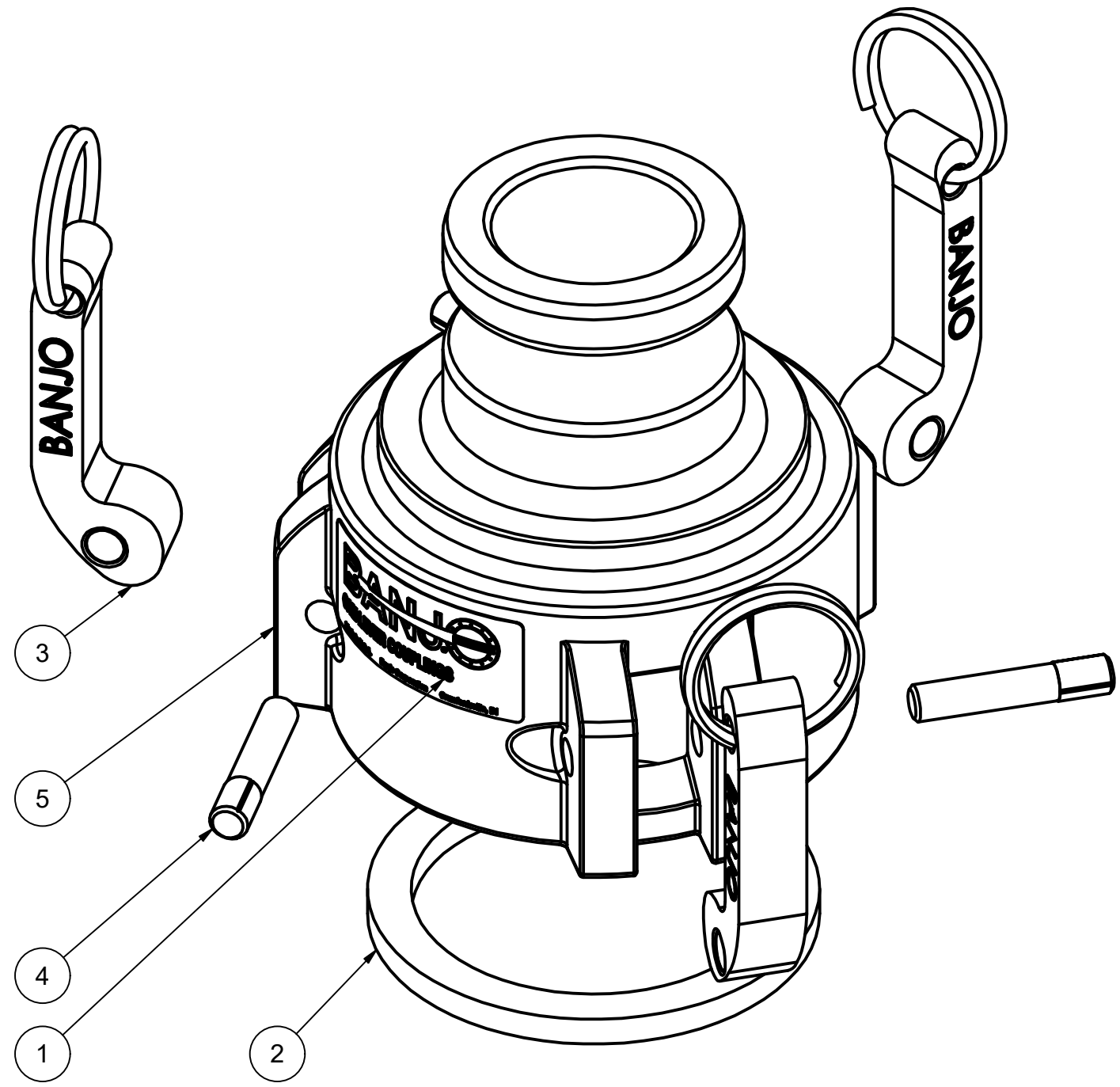
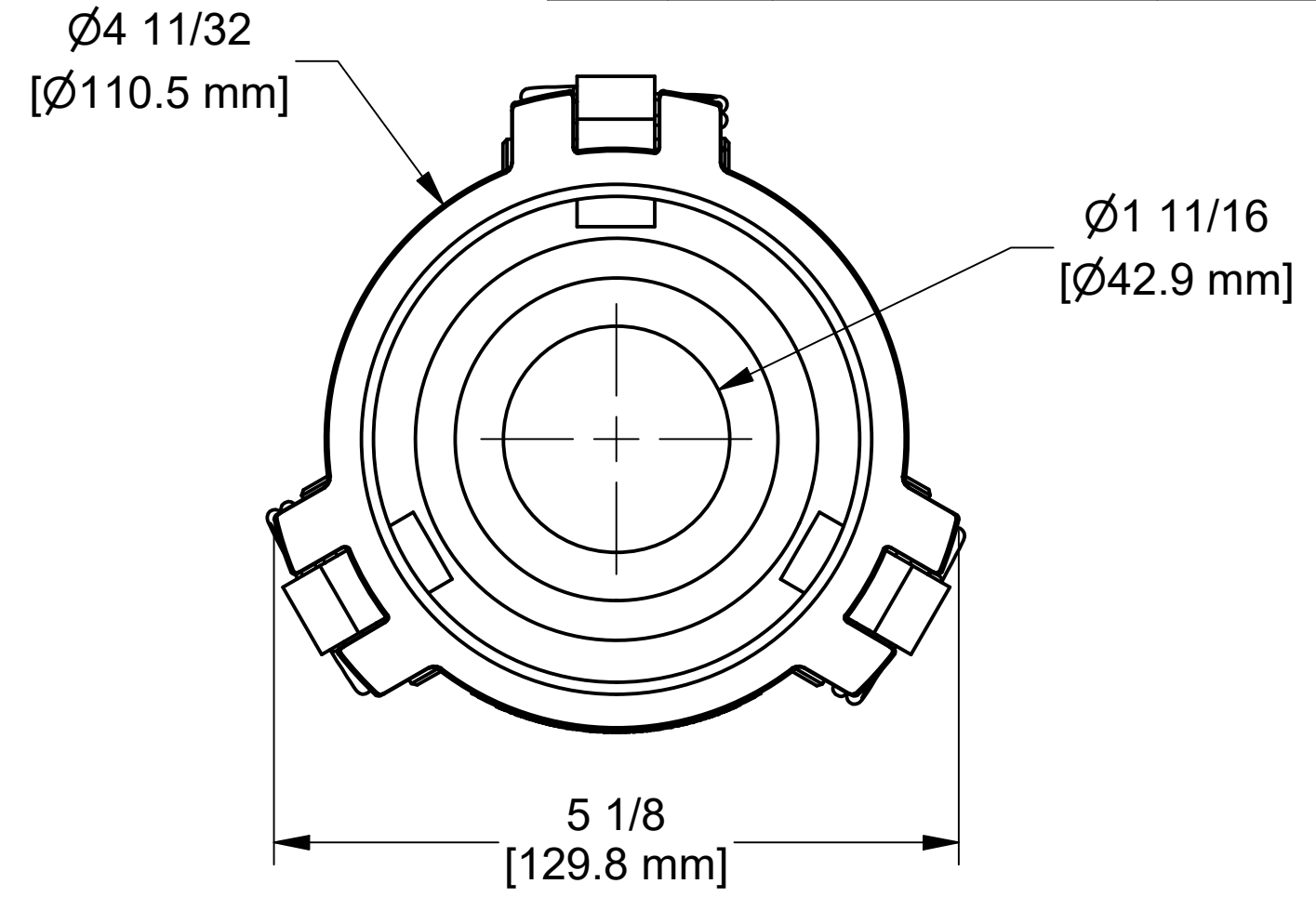
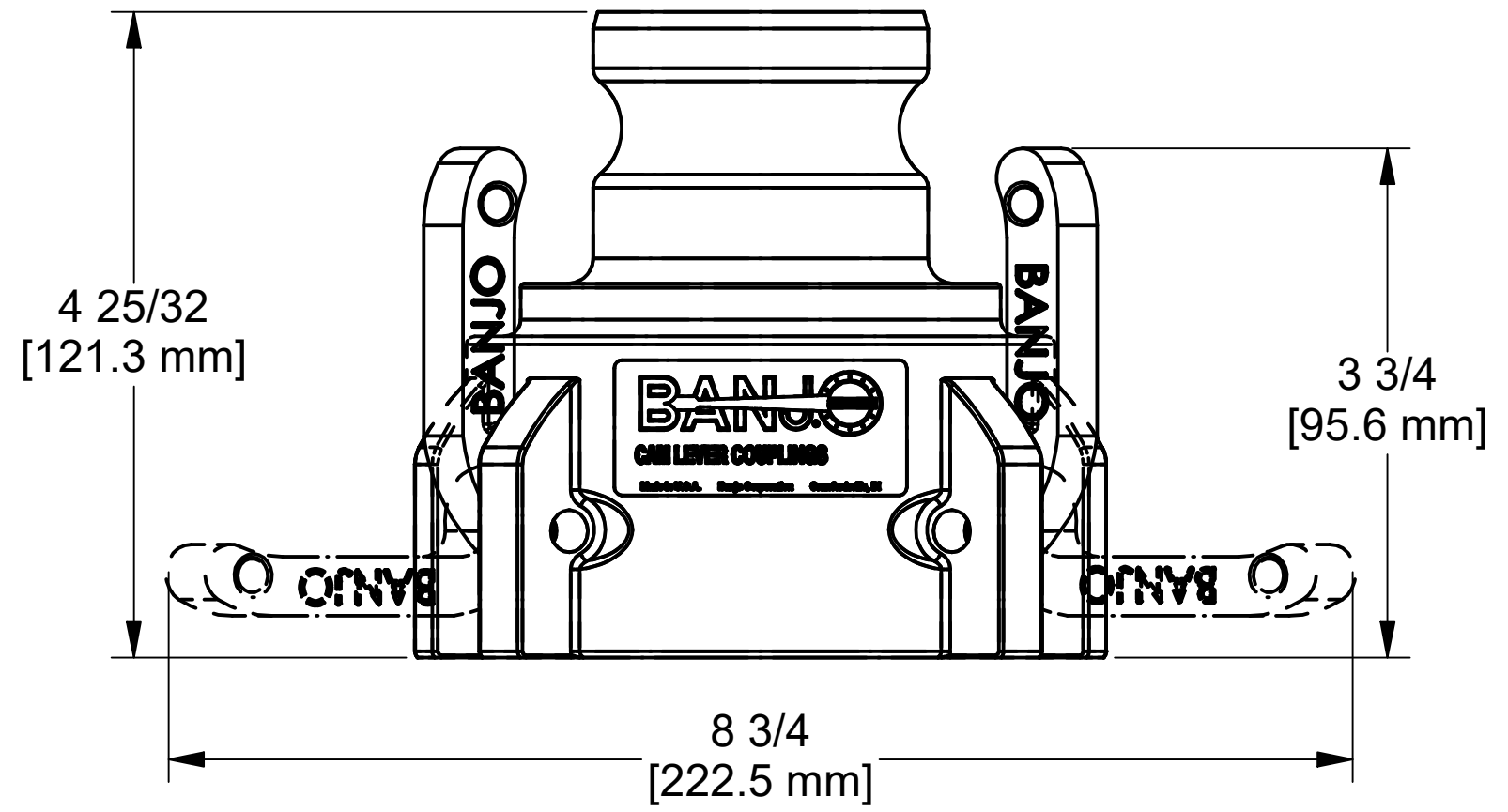

THIS DRAWING AND ALL INFORMATION CONTAINED THEREON ARE THE EXCLUSIVE PROPERTY OF BANJO CORPORATION.

UNLESS SPECIFICALLY NOTED, THIS DRAWING AND ITEMS SHOWN ON THIS DRAWING ARE SUBJECT TO CHANGE AT ANY TIME.

BANJO CORPORATION
150 BANJO DRIVE, CRAWFORDSVILLE, IN 47933
WEB SITE: WWW.BANJOCORP.COM
E-MAIL: BANJOSALES@IDEXCORP.COM

DESCRIPTION
3" FEMALE COUPLER X 2" MALE ADAPTER

PART NUMBER
303B200A