



► Model 50GC

SelecTone® Amplified Speaker

Model 50GC SelecTone® Amplified Speaker is designed to produce crisp, clear tones, digital voice messages and live public address.

In the Model 50GC a short, folded re-entrant horn is interposed between the diaphragm and surrounding air space. This design provides optimal dBa output and frequency response.

When installed with the Model WB Weatherproof Backbox, the 50GC is suitable for use outdoors.

SelecTone Amplified Speakers are used individually or as part of a plant-wide emergency notification system. The Model UTM Universal Tone Module, with 32 tones, or the TM33 Custom Tone Module is plugged into a single SelecTone Amplified Speaker for stand-alone use or into a SelecTone Command Unit for plant-wide signaling.

For plant-wide signaling, a Connector Kit is installed into each SelecTone Amplified Speaker and wired to a central controller. SelecTone Command Units and CommCenter® Digital Message Centers broadcast tones, voice messages, melodies and live public address to an unlimited number of SelecTone Amplified Speakers.

The compact size and attractive appearance of the Model 50GC make it ideal for use in offices, hallways, reception, and plant areas where ambient noise levels are not exceedingly high, and even sound dispersal is desired. Emergency signaling and paging are common applications.

FEATURES

- Available in 24VAC/DC and 120VAC
- Solid-state circuitry
- Built-in gain control, adjustable between 64 dBa to 88 dBa @ 10' (74 dBa to 98 dBa @ 1m)
- Flush or surface mount
- Type 3R enclosure when used with the WB backbox
- UL and cUL Listed, and CSFM Approved

MODEL	VOLTAGE	OPERATING CURRENT	STANDBY CURRENT*	DECIBELS	
				10'	1M
50GC-024BG	24VDC 24VAC 50/60Hz	0.09 amps	0.037 amps	88	98
		0.29 amps	0.147 amps	88	98
50GC-120BG	120VAC 50/60Hz	0.04 amps	0.027 amps	88	98

*When used as a powered loud speaker

SelecTone® Amplified Speaker (50GC)

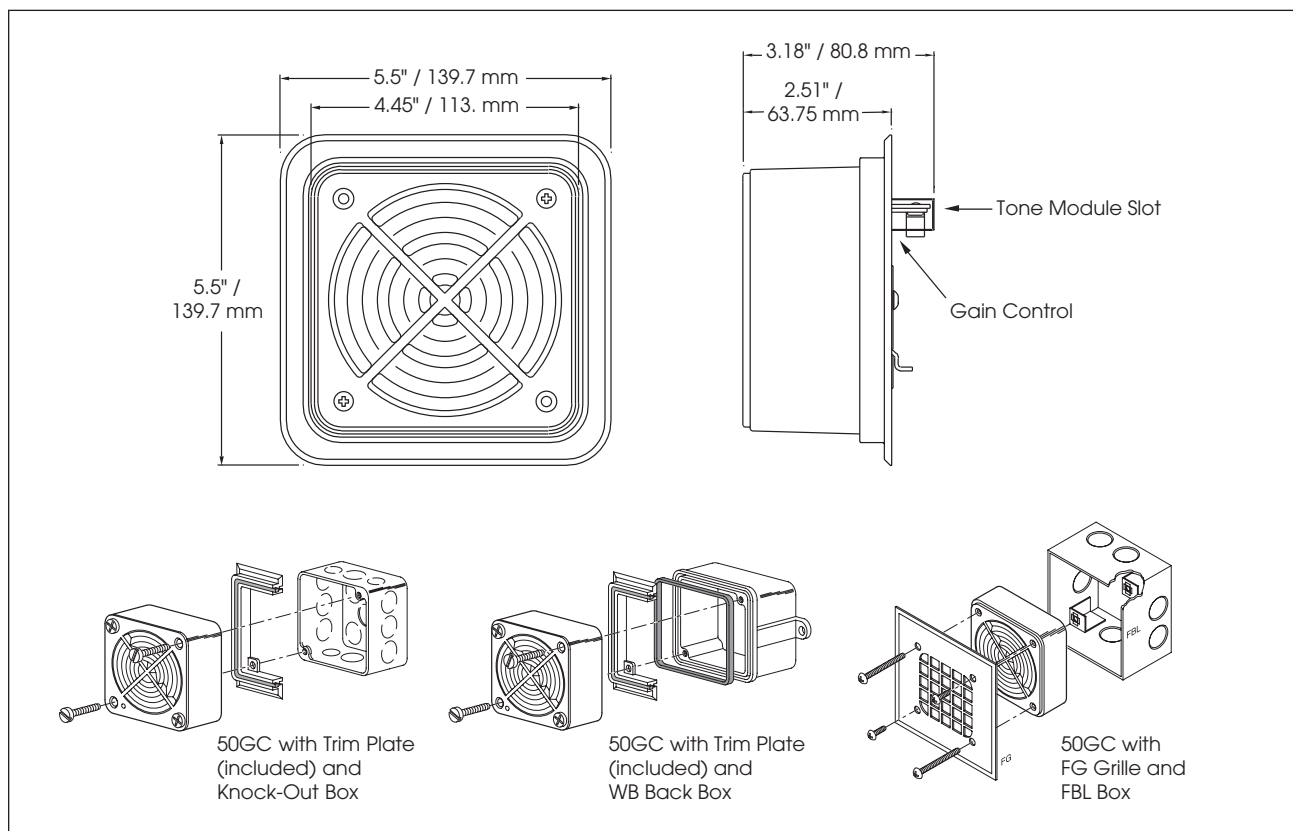

SPECIFICATIONS

Operating Temperature:	-31°F to 151°F	-35°C to 66°C
Net Weight:	1.7 lbs	0.8 kg
Shipping Weight:	2.2 lbs	1.0 kg
Height:	5.5"	139.7 mm
Width:	5.5"	139.7 mm
Depth:	3.18"	80.8 mm

OPTIONAL ACCESSORIES

Description	Part Number
Weatherproof Back Box	WB
Grille	FG
Flush Mount Back Box	FBL

HOW TO ORDER

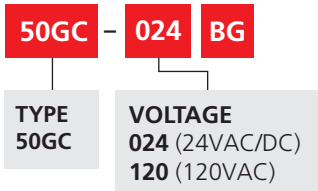

Specify Tone Module:

For stand alone operation

UTM – Universal Tone Module

(Reference page 199 for list of tones)

TM33 – Custom Tone Module

(Reference page 201 for list of tones)

Specify Connector Kit:

(sold separately) for use in systems

Call factory for system design assistance.

(Reference page 202 for Connector Kits)

AM25CK – 25 Vrms, 1 Vrms

AM70CK – 70 Vrms, 1 Vrms

300CK – 10 Vrms, 1 Vrms

T-300CK – 2.7 Vrms, 1 Vrms

E-300CK – 1 Vrms, 1 Vrms