

# Spoolmatic® and XR-Pistol™

## Pistol-Grip Guns

MIG Guns for Aluminum Welding 

### Quick Specs

#### Heavy Industrial Applications

Emergency Vehicles	Shipbuilding
Recreational Vehicles	Tool Boxes
Trucks and Trailers	Railcars
Boat/Yacht Building	Fabrication
Sign Manufacturers	

#### Processes

MIG (GMAW) with aluminum wire and other soft alloys  
Pulsed MIG (GMAW-P) with pulsing power source

#### Rated Output at 100% Duty Cycle

Spoolmatic: 200 A  
XR-Pistol (Air-Cooled): 200 A  
XR-Pistol (Water-Cooled): 400 A

#### Net Weight (Gun Only)

Spoolmatic: 2.9 lb. (1.3 kg)  
XR-Pistol (Air-Cooled): 2.2 lb. (1 kg)  
XR-Pistol (Water-Cooled): 2.4 lb. (1.1 kg)

**Spoolmatic spool gun** is available with 15- or 30-foot (4.6 or 9 m) cable lengths. The well-balanced industrial spool gun features a built-in gas valve, rotatable canister, and all-wire dual-groove drive roll.



**Head tubes are FasTip™ and Bernard™ Centerfire™ compatible.** Head tube comes standard with FasTip consumables. (See page 4 for FasTip and optional Bernard consumables.)

**Easy access to drive assembly and removable head tube** reduces service time by allowing a simple means of changing drive rolls and head tube or performing routine maintenance without disassembly of gun.

**Quick-change, single-turn contact tip** provides excellent performance and ease of replacement.

**Wire speed on gun handle and reversible drive rolls** save time and money.

**Improved power block on Spoolmatic.**

The **Spoolmatic®** is designed to be used with the **WC-24, WC-115 weld control** or as a direct connect to select Millermatic power sources.

**A complete system consists of the following:**

- **Spoolmatic spool gun**  
(Includes .035–1/16 in. dual drive roll and two FasTip™ contact tips — .035 in. and 3/64 in.)
- **WC-24 or WC-115 weld control**  
(Required unless using a machine that allows direct hookup.)
- **Recommended Miller 14-pin power source OR select Milleramics** (See page 4.)

**XR-Pistol push-pull gun** is available in air- or water-cooled versions with 15- or 30-foot (4.6 or 9 m) cable lengths. The replaceable feed cable liner saves time and money, while the trigger hold, when paired with the XR-S/D Control or XR-AlumaFeed, eliminates hand strain. Also has a full leather cable cover with full length hook-and-loop closure for easy maintenance.



**Replaceable feed cable liner** reduces parts cost and service time by allowing a simple means of removing and replacing liner and not the complete feed cable. (XR-Pistol only.)

**Trigger hold** reduces fatigue by allowing operator to weld without holding trigger. (Feature only available when XR-Pistol is paired with XR-S/D Control or XR-AlumaFeed.)



The **XR™-Pistol** is designed to be used with the **XR™-S/D Control** or **XR-AlumaFeed™** as part of a push-pull system.

**A complete system consists of the following:**

- **XR-Pistol push-pull gun**
- **XR-S/D Control OR XR-AlumaFeed**  
(See Lit. Index No. M/1.7 or DC/34.)
- **Recommended Miller 14-pin power source OR select Milleramics** (See page 3.)



Guns are warranted for 1 year, parts and labor.



**Miller Electric Mfg. Co.**  
An ITW Company  
1635 West Spencer Street  
P.O. Box 1079  
Appleton, WI 54912-1079 USA

**Equipment Sales US and Canada**  
Phone: 866-931-9730  
FAX: 800-637-2315  
International Phone: 920-735-4554  
International FAX: 920-735-4125

**MillerWelds.com**  
  



# Spoolmatic® Specifications (Subject to change without notice.)



Welding Current Rating	Wire Feed Speed	Wire Diameter Capacity	Maximum Spool Size Capacity	Gun Dimensions	Net Weight
200 A at 100% duty cycle	70–875 IPM (1.8–22.2 m/min.) dependent on control box or Millermatic used	Aluminum: .030–1/16 in. (0.8–1.6 mm) Hard Wire: .030–.045 in. (0.8–1.1 mm)	4 in. (102 mm)	H: 10.25 in. (260 mm) W: 2.5 in. (64 mm) L: 15.125 in. (384 mm)	Gun only: 2.9 lb. (1.3 kg) 15-ft. gun with cable: 9 lb. (4.1 kg) 30-ft. gun with cable: 14 lb. (6.4 kg)

## Spoolmatic® Air-Cooled Parts Breakdown

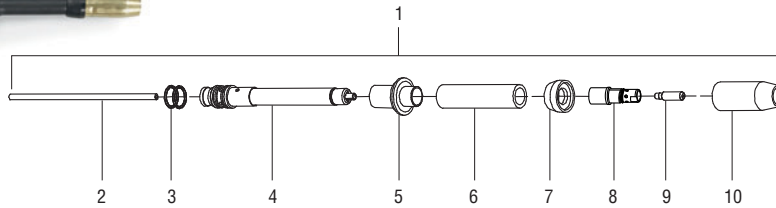

- 1. Air-Cooled Assembly **Kit #221 295**
- 2. Head Tube Liner **#212 156**
- 3. O-Ring .614 ID **#134 800**
- 4. Head Tube (Air-cooled) **#221 087**
- 5. Head Tube Pistol Insulator **#219 795**
- 6. Outer Insulating Jacket **#219 794**
- 7. Nozzle Insulator **#232 284**
- 8. Diffuser **#227 749**
- 9. Contact Tip (See consumables)
- 10. Nozzle (See optional consumables)

## Spoolmatic® Standard Replacement Consumables (Order from Miller Service Parts.)

Aluminum Wire Size	FasTip Contact Tip (Qty. 25)	Drive Rolls	All-Wire Dual-Groove Drive Rolls	Head Tube Liner
.030 in. (0.8 mm)	<b>#206 186</b> .041-in. ID	<b>#183 357</b>	<b>#136 135</b>	<b>#212 156</b>
.035 in. (0.9 mm)	<b>#206 187</b> .047-in. ID	<b>#183 357</b>	<b>#136 135</b>	<b>#212 156</b>
.040 in. (1.0 mm)	<b>#206 188</b> .053-in. ID	<b>#183 357</b>	<b>#136 135</b>	<b>#212 156</b>
3/64 in. (1.2 mm)	<b>#206 189</b> .061-in. ID	<b>#183 358</b>	<b>#136 135</b>	<b>#212 156</b>
1/16 in. (1.6 mm)	<b>#206 191</b> .071-in. ID	<b>#183 358</b>	<b>#136 135</b>	<b>#212 156</b>

Each gun is shipped with .035-inch and .047-inch standard tips.

## Typical Installations

Note: Cords and cables are supplied unless noted otherwise on drawings below. Refer to Owner's Manual for complete installation instructions.

To connect the Spoolmatic gun and WC-24 control to older-style Miller or competitive CV power sources that do not have a 24 VAC supply, the PSA-2 control **#141 604** is required.

To connect Spoolmatic gun and WC-24 control to Millermatic® 200 power source that has a 4-pin receptacle, order adapter cord **#042 236**.

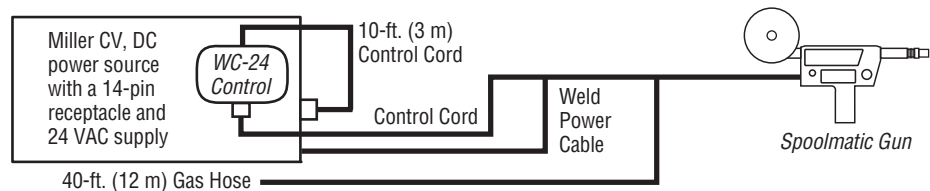

To connect the WC-115A control to older-style Miller power sources having Hubbell or 5-pin contactor control receptacles, the appropriate connector must be ordered **separately**.

To connect to older-style Miller CC power sources having a two-socket Hubbell connector, order plug **#039 618**.

If power source has a Miller 5-pin receptacle, order **#039 273 and #039 685**.

To connect to older-style Miller CV power sources having a two-prong Hubbell connector, order plug **#039 635**.

Note: These connectors are to replace the 14-pin connector on the 10-foot interconnect contactor cord. Internal wiring changes may be necessary.

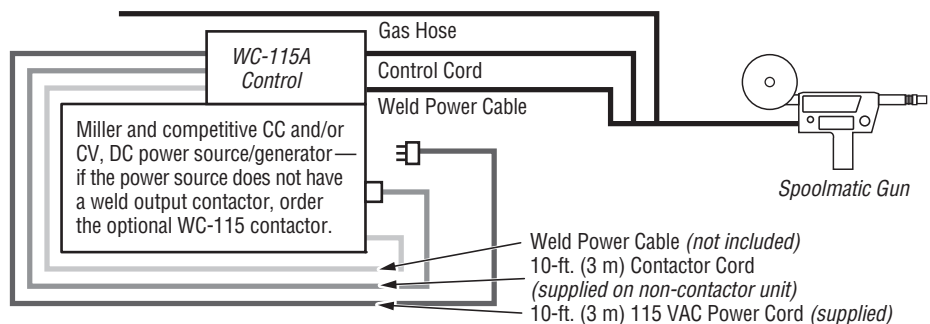

# XR™-Pistol Specifications (Subject to change without notice.)



Model	Welding Current Rating	Wire Feed Speed	Wire Diameter Capacity	Dimensions	Net Weight
XR-Pistol (air-cooled)	200 A at 100% duty cycle 250 A at 60% duty cycle	70–875 IPM (1.8–22.2 m/min.)	.030–1/16 in. (0.8–1.6 mm) aluminum wire	H: 7.375 in. (187 mm) W: 1.875 in. (48 mm) D: 10.625 in. (270 mm)	Gun only: 2.2 lb. (1 kg) 15-ft. gun with cable: 13 lb. (5.9 kg) 30-ft. gun with cable: 21 lb. (9.5 kg)
XR-Pistol (water-cooled)	400 A at 100% duty cycle				Gun only: 2.4 lb. (1.1 kg) 15-ft. gun with cable: 14 lb. (6.4 kg) 30-ft. gun with cable: 21.5 lb. (9.8 kg)

## XR™-Pistol Air-Cooled Parts Breakdown

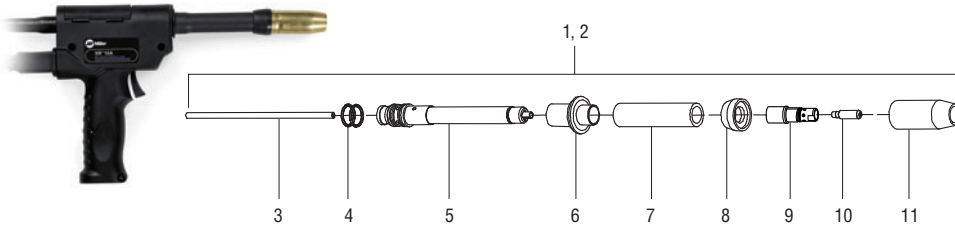

- |                               |                            |
|-------------------------------|----------------------------|
| 1. Air-Cooled Assembly        | <b>Kit #231 523</b>        |
| 2. Water-Cooled Assembly*     | <b>Kit #231 524</b>        |
| 3. Head Tube Liner            | <b>#212 156</b>            |
| 4. O-Ring .614 ID             | <b>#134 800</b>            |
| 5. Head Tube (Air-cooled)     | <b>#221 087</b>            |
| Head Tube (Water-cooled)*     | <b>#221 519</b>            |
| 6. Head Tube Pistol Insulator | <b>#219 795</b>            |
| 7. Outer Insulating Jacket    | <b>#219 794</b>            |
| 8. Nozzle Insulator           | <b>#232 284</b>            |
| 9. Diffuser                   | <b>#227 749</b>            |
| 10. Contact Tip               | (See consumables)          |
| 11. Nozzle                    | (See optional consumables) |

\*Order water-cooled parts from Miller Service Parts.

## XR™-Pistol Standard Replacement Consumables (Air-cooled only.) (Order from Miller Service Parts.)

Aluminum Wire Size	FasTip Contact Tip (Qty. 25)	Drive Rolls	All-Wire Dual Groove Drive Rolls	Head Tube Liner	Cable Liners
.030 in. (0.8 mm)	<b>#206 186</b> .041-in. ID	<b>#183 357</b>	<b>#136 135</b>	<b>#212 156</b>	<b>#191 065</b> 15 or 30 ft. (4.6 or 9 m)
.035 in. (0.9 mm)	<b>#206 187</b> .047-in. ID	<b>#183 357</b>	<b>#136 135</b>	<b>#212 156</b>	
.040 in. (1.0 mm)	<b>#206 188</b> .053-in. ID	<b>#183 357</b>	<b>#136 135</b>	<b>#212 156</b>	
3/64 in. (1.2 mm)	<b>#206 189</b> .061-in. ID	<b>#183 358</b>	<b>#136 135</b>	<b>#212 156</b>	
1/16 in. (1.6 mm)	<b>#206 191</b> .071-in. ID	<b>#183 358</b>	<b>#136 135</b>	<b>#212 156</b>	

## Typical Installations

Note: Cords and cables are supplied unless noted otherwise on drawings below. Refer to Owner's Manual for complete installation instructions.

### XR-Pistol Grip Gun

#### Hook-Up Recommendations

CV Power Supply	Control
Millermatic® 252, 350P, 350P Aluminum	Direct Hook-Up
AlumaPower™ 350 MPa, 450 MPa Deltaweld® Series Dimension™ Series Invision™ Series XMT® Series (except VS model) Big Blue® 300, 350 PipePro® Trailblazer® 275, 325, 302 Air Pak™	XR™-S/D Control or XR-AlumaFeed™

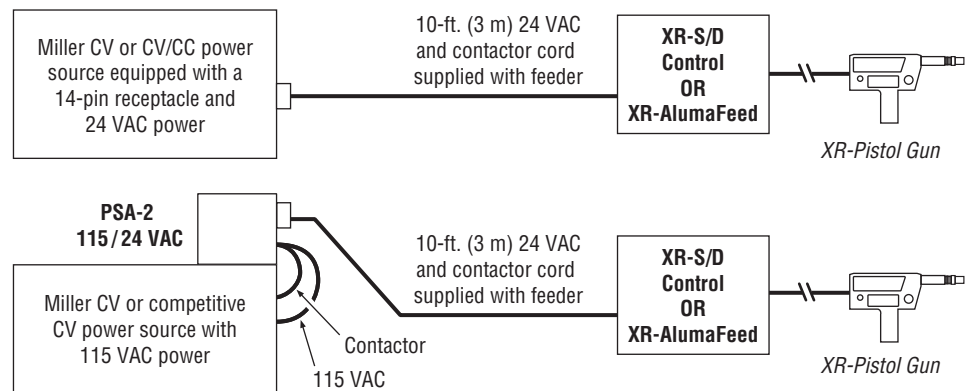

## Standard Consumables – FasTip™ Series (Order from Miller Service Parts.)

### Gas Diffusers



#### #227 749 Standard

1/8-inch tip recess for heavy-duty FasTip contact tips.

#### #231 511

1/4-inch tip recess for heavy-duty FasTip contact tips.

#### #231 512

Flush tip for heavy-duty FasTip contact tips.

### FasTip Contact Tips

*(25 per package)*



#### Heavy-Duty (Aluminum Wire)

#206 186 .030 in. (0.8 mm)

#206 187 .035 in. (0.9 mm)

#206 188 .040 in. (1.0 mm)

#206 189 3/64 in. (1.2 mm)

#206 191 1/16 in. (1.6 mm)

#### Tapered (Aluminum Wire)

#209 026 .030 in. (0.8 mm)

#209 027 .035 in. (0.9 mm)

#209 029 3/64 in. (1.2 mm)

#206 030 1/16 in. (1.6 mm)

### Nozzles

#### Screw-On Brass

#199 610 1/2-in. orifice, tapered

#199 611 3/4-in. orifice, straight

#199 612 3/4-in. orifice, straight HD

#199 613 5/8-in. orifice, tapered

#199 614 5/8-in. orifice, tapered HD

#### Screw-On Copper

#199 615 1/2-in. orifice, tapered

#199 616 3/4-in. orifice, straight

#199 617 3/4-in. orifice, straight HD

#198 855 5/8-in. orifice, tapered

#199 618 5/8-in. orifice, tapered HD

#207 313 5/8-in. orifice, tapered 15/16 OD

#209 035 3/8-in. orifice, tapered

#209 036 1/2-in. orifice, tapered

## Optional Consumables – Centerfire™ Series (Order from Miller Service Parts.)

### Insulator 10012

4323R

### Diffuser D-1 (large)

DS-1 (small)

### Aluminum-Specific T Series Contact Tips

T-035AL .035 in. (0.9 mm)

T-047AL .047 in. (1.2 mm)

T-062AL 1/16 in. (1.6 mm)

### T Series Contact Tips for Hard or Cored Wires 1.5 in. (38.1 mm)

T-030 .030 in. (0.8 mm)

T-035 .035 in. (0.9 mm)

T-039 .039 in. (1.0 mm)

T-045 .045 in. (1.2 mm)

T-052 .052 in. (1.4 mm)

T-062 1/16 in. (1.6 mm)

### TT Series Contact Tips for Hard or Cored Wires 2 in. (50.8 mm)

TT-030 .030 in. (0.8 mm)

TT-035 .035 in. (0.9 mm)

TT-045 .045 in. (1.2 mm)

TT-052 .052 in. (1.4 mm)

TT-062 1/16 in. (1.6 mm)

### Large Nozzles

N-3414C Copper, 3/4-in. I.D., 1/4-in. tip recess

N-3418B Brass, 3/4-in. I.D., 1/8-in. tip recess

N-3414B Brass, 3/4-in. I.D., 1/4-in. tip recess

N-5814C Copper, 5/8-in. I.D., 1/4-in. tip recess

N-5818B Brass, 5/8-in. I.D., 1/8-in. tip recess

N-5814B Brass, 5/8-in. I.D., 1/4-in. tip recess

### Small Nozzles

NS-5818B Brass, 5/8-in. I.D., 1/8-in. tip recess

NS-1218B Brass, 1/2-in. I.D., 1/8-in. tip recess

NS-1200B Brass, 1/2-in. I.D., flush tip

NST-3818B Brass, 3/8-in. I.D., 1/8-in. tip recess

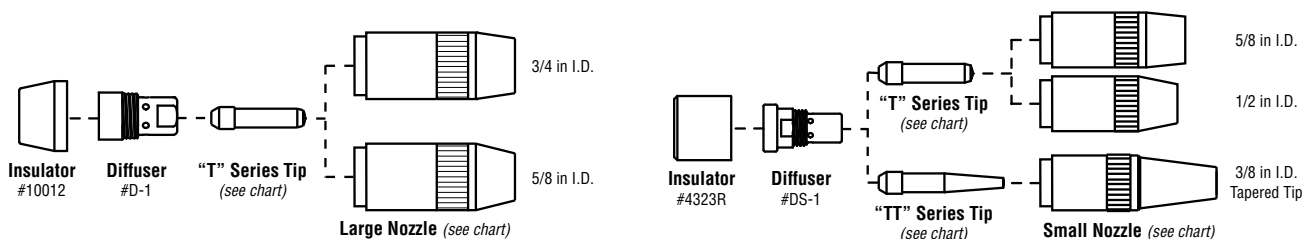

## Genuine Miller® Accessories

### Hose and Cable Extension Kits

**#132 228** 25 ft. (7.6 m)

**#132 229** 50 ft. (15 m)

Extends Spoolmatic away from the control box. Convenient plug-in connections. Includes gas hose, control cord, and weld power cable with International-style insulated connector. *For Spoolmatic only.*

### Hardwire Liner Kit for Steel and Stainless

**#198 377** For 15- or 30-ft. guns  
(4.6 or 9 m)

Kit consists of gun head tube liner and feed cable liner. Recommend using .030–.045 inch mild steel or stainless steel electrode wire. *For XR-Pistol only.*

*Note: .052- and 1/16-inch wires not recommended.*

### Leather Cable Cover

**#241 159** 15 ft. (4.6 m)

**#241 160** 30 ft. (9 m)

Protects gun hose and cable assembly from wear and abrasion. Features full-length hook-and-loop closure for ease of maintenance or replacement.



### One-Pound (0.5 kg) Spool Canister

**#132 230**

Ideal for use with XR guns if a small job arises requiring a different wire size and/or wire type that does not justify a 12-inch (305 mm) spool of wire. The XR feed cable is removed if the spool canister is being used. Canister accommodates 4-inch (102 mm) spools of wire.

### Air-Cooled Head Tubes

*For Spoolmatic and XR-Pistol.*



#### 50-Degree Curved Head Tube-A

**#222 462** *For FasTip™ consumables*

6-inch (152 mm). Used with .030–1/16 inch (0.8–1.6 mm) wire. Kits supplied with liner that accommodates all wire sizes.



#### 10-Inch Flex Head-A **#222 735**

For .030–1/16 inch (0.8–1/6 mm) wire. Used in place of the standard straight head tube. Flexible head tube bends 60 degrees in any direction for easier joint access and improved operator comfort. Supplied with liners. Uses FasTip™ contact tips.



#### 10-Inch Head Tube-A **#222 461**

Ideal when a longer reach is required.

### Replacement Liners for Air-Cooled Head Tubes

*(Order from Miller Service Parts.)*

#### For 50-Degree Curved Head Tube

**#212 411** .030–1/16 in. (0.8–1.6 mm)

#### For 10-Inch Flex Head

**#222 853** .030–.035 in. (0.8–0.9 mm)

**#222 854** .047–.062 in. (1.2–1.6 mm)

#### For 10-Inch Head Tube

**#212 401** .030–1/16 in. (0.8–1.6 mm)

### 50-Degree Curved Nozzle Kit-A

*(Order from Miller Service Parts.)*

**#147 174** For old-style multi-piece head tubes

**#300 161** For newer Roughneck®-style head tubes

Attaches to gun head tube assembly for access to confined weld joint areas. Used with .030–1/16 inch (0.8–1.6 mm) wire. Kit includes two of each size contact tips to accommodate all wire sizes, nozzle adapter kit and curved nozzle. Uses standard straight head tube liner.

### Replacement Contact Tips for 50-Degree Curved Nozzle

*(Order from Miller Service Parts.)*

**#148 155** .030 and .035-in.  
(0.8 and 0.9 mm) wire

**#148 154** .047-in. (1.2 mm) wire

**#148 156** 1/16-in. (1.6 mm) wire

### Water-Cooled Head Tubes

*For XR-Pistol only.*



#### 50-Degree Curved Head Tube-W

**#222 464**

6-inch (152 mm). Used with .030–1/16 inch (0.8–1.6 mm) wire. Kits supplied with liner that accommodates all wire sizes.

### Replacement Liners for Water-Cooled Head Tubes

*(Order from Miller Service Parts.)*

#### For 50-Degree Curved Head Tube

**#212 411** .030–1/16 in. (0.8–1.6 mm)

#### For 10 in Straight Head Tube

**#212 401** .030–1/16 in. (0.8–1.6 mm)



# Spoolmatic Spool Gun Controls

## Spoolmatic Hook-Up Recommendations

CV Power Supply	Spoolmatic
Millermatic® Vintage*	Need Module <b>#043 084</b>
Millermatic® DVI™*, DVI <sub>2</sub> ™*, 210*, 212*	Need Adapter Cable <b>#195 287</b> (WFS controlled at machine)
Millermatic® 212 Auto-Set™, 250X*, 251*, 252, 300 w/meters*, 350*, 350P, Shopmate™ 300 DX	Direct Hook-Up
AlumaPower™ MPa, CP Series, Deltaweld® Series, Dimension™ Series, Invision™ MPa, Regency® 250*, Shopmaster™*, XMT® Series, PipePro® 304*, Trailblazer® 275, 275 DC*, 302*, 302 Air Pak™, 325	Need WC-24 <b>#137 549</b>
Bobcat™ Series, Miller Legend® 302*	Need WC-115A <b>#137 546-01-1</b>

\*Discontinued product.



**WC-115A Weld Control #137 546** Without contactor  
**#137 546-01-1** With contactor  
 This control operates on 115 VAC, and is designed primarily for CC DC power sources. It can also be used with CV power sources or DC engine drives supplying 115 VAC. When used with a CC source, the

control circuit functions in a voltage-sensing mode. When used with a CV source, it functions as a constant-speed circuit.

Standard features include a wire run-in control and a drive motor acceleration control which ensure optimum arc starting performance, regardless of the type of power source being used. The WC-115A comes with a 10-foot (3 m), wall-type plug power cord.



**WC-24 Weld Control #137 549**  
 Packaged in a compact, lightweight, non-metallic enclosure, the WC-24 easily mounts directly on the power source. It's designed for use with Miller CV power sources supplying 24 VAC and 14-pin receptacles. The control includes a board-mounted potentiometer which can alter the drive motor acceleration rate to optimize arc starting performance.



## Ordering Information

### Important notes:

Spoolmatic guns require a WC-24 or WC-115 weld control, unless used on a machine that allows direct hookup. Refer to chart on page 6.

XR-Pistol Grip Guns require XR-S/D Control or XR-AlumaFeed, or may be direct connected to a Millermatic 252, 350P or 350P Aluminum.

XR-Control must be serial #KK309906 or higher to be used with products and descriptions mentioned in this literature. To confirm a product's compatibility with older equipment, please contact the factory at 1-920-735-4505.

Equipment	Stock No.	Description	Qty.	Price
<b>Spoolmatic® Spool Gun</b>	<b>#195 156</b>	15-ft. (4.6 m) cable		
	<b>#130 831</b>	30-ft. (9 m) cable		
WC-24 Weld Control	<b>#137 549</b>	For Spoolmatic guns		
WC-115A Weld Control	<b>#137 546</b>	Without contactor. For Spoolmatic guns		
	<b>#137 546-01-1</b>	With contactor. For Spoolmatic guns		
<b>XR™-Pistol Push-Pull Gun (Air-Cooled)</b>	<b>#198 127</b>	15-ft. (4.6 m) cable		
	<b>#198 128</b>	30-ft. (9 m) cable		
<b>XR™-Pistol Push-Pull Gun (Water-Cooled)</b>	<b>#198 129</b>	15-ft. (4.6 m) cable		
	<b>#198 130</b>	30-ft. (9 m) cable		
XR™-S Control (See Lit. Index No. M/1.7)	<b>#300 601</b>	Standard model includes .035- and 3/64-in. drive rolls, wire feed speed digital display, jog/purge, run-in control, and trigger hold		
XR™-D Control (See Lit. Index No. M/1.7)	<b>#300 687</b>	Enhanced model includes .035- and 3/64-in. drive rolls, has same features as XR-S, plus advanced digital and programming capabilities		
XR-AlumaFeed™ (See Lit. Index No. DC/34)	<b>#300 509</b>	Advanced model includes .035- and 3/64-in. drive rolls, and adds Profile Pulse™, synergic control, trigger schedule select, lock capabilities and flowmeter		
XR-Control/AlumaFeed Drive Roll	<b>#195 591</b>	1/16 in (1.6 mm). <i>Order from Miller Service Parts.</i>		
<b>Consumables and Accessories</b>				
Consumables		See pages 2–5		
Hose and Cable Extension Kits	<b>#132 228</b>	25 ft. (7.6 m). Spoolmatic only		
	<b>#132 229</b>	50 ft. (15 m). Spoolmatic only		
Hardware Liner Kit for Steel and Stainless	<b>#198 377</b>	For 15- or 30-ft. (4.6 or 9 m) guns. XR-Pistol only		
Leather Cable Cover	<b>#241 159</b>	15 ft. (4.6 m)		
	<b>#241 160</b>	30 ft. (9 m)		
One-Pound Spool Canister	<b>#132 230</b>			
Head Tubes		See page 6		
Coolant Systems		See Lit. Index No. AY/7.2		

Date:

Total Quoted Price:

Distributed by:

