

DOCK BARRICADE - DJG-100

APPROX WEIGHT: 782.93 lbs.
DOES NOT INCLUDE WEIGHT OF POWER OR PACKAGING!!!

*** ANY ADDITIONS, DELETIONS, OR OMISSIONS MUST BE CORRECTED ON THIS DRAWING AS THIS DRAWING WILL BE CONSIDERED ALL INCLUSIVE ***

ALL GRAPHICS PROVIDED ARE FOR REFERENCE ONLY. IF CERTAIN DIMENSIONS ARE CRITICAL PLEASE VERIFY THOSE DIMENSIONS WITH YOUR SALESPERSON

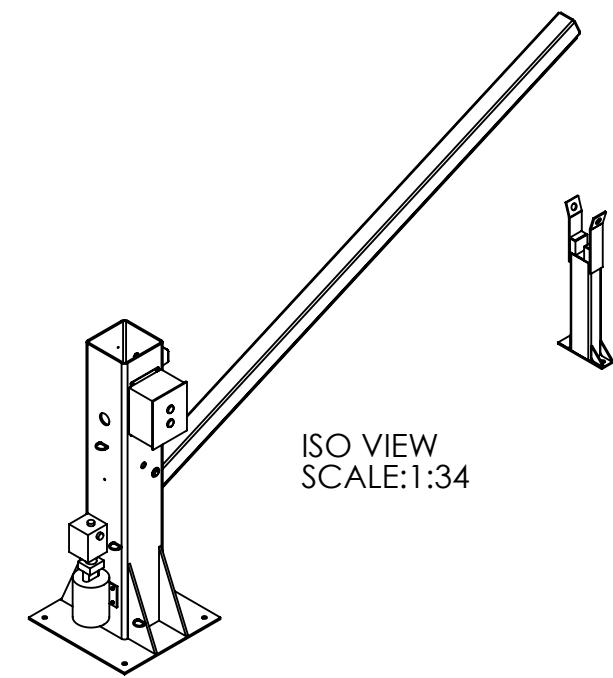
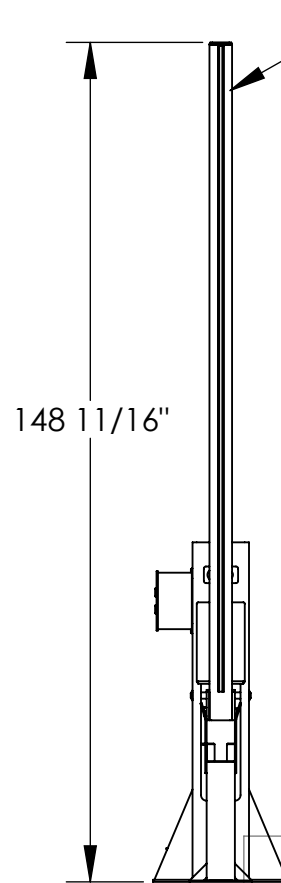
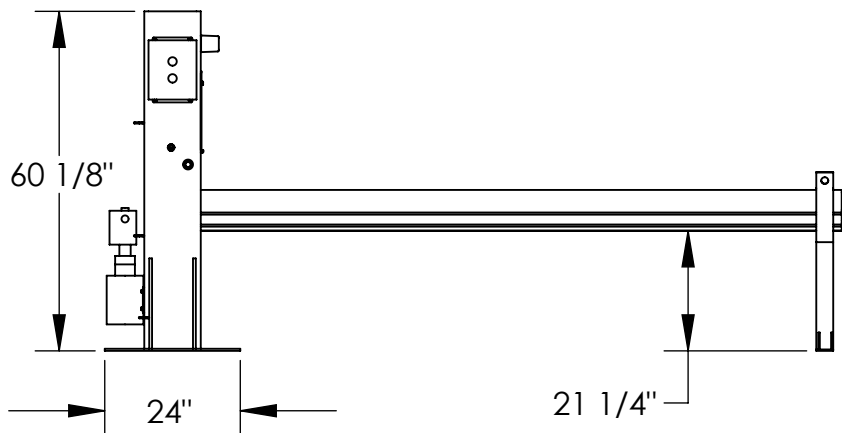
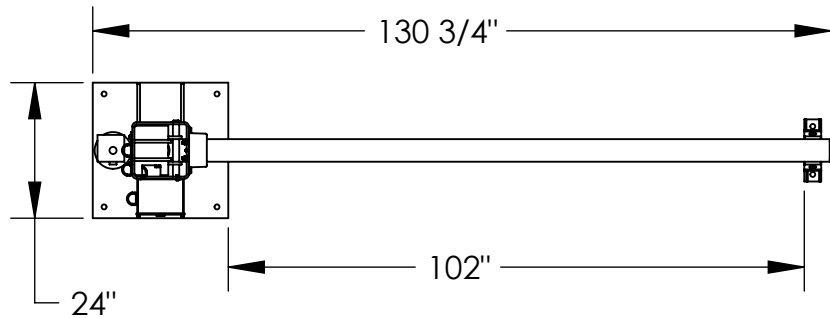

ISO VIEW
SCALE:1:34

APPROVAL

I, THE UNDERSIGNED, AGREE THAT THE PRODUCT AS REPRESENTED SATISFIES DESIGN AND DIMENSION REQUIREMENTS. I ALSO ACKNOWLEDGE MY DUTY TO CONFIRM PRODUCT AND INSTALLATION COMPLIANCE WITH ALL APPLICABLE FEDERAL, STATE AND LOCAL REGULATIONS AND STANDARDS.
ALL SPECIAL UNITS ARE NON-RETURNABLE
[] As drawn [] As marked

Signed: _____ Date: _____

LEAD TIME WILL START UPON RECEIPT OF SIGNED APPROVAL DRAWING

STANDARD FEATURES

- MODEL NUMBER IS: DJG-100
- OVERALL WIDTH IS: 24"
- OVERALL LENGTH IS: 130 3/4"
- USABLE LENGTH IS: 102"
- ARM HEIGHT RAISED IS: 148 11/16"
- ARM HEIGHT LOWERED IS 28 1/2"

SPECIAL FEATURES

NONE

PLEASE CIRCLE SPECIFICATIONS:

POWER	AC	* DC	* AIR/OIL
MOTOR VOLTAGE	115	208	230 460
DEDICATED CIRCUIT REQUIRED			
MOTOR PHASE	SINGLE	THREE	
CONTROL	HAND	* FOOT	
~ ALL BATTERY CHARGERS ARE 115V AC ~			
* BATTERY CHRG.	REMOTE	ON-BOARD	
* CHRG. INDICATOR	YES	NO	

* AVAILABLE AT ADDITIONAL COST

DISTRIBUTOR'S NAME:		P.O.#	X
DRAWN BY: M. VARYS		DATE: 07/11/07	W.O.#
REFERENCE: X		SCALE: 1:34	SALES: X
QUOTED LEAD TIME: X		QUOTE #	FILE NAME:
		X	23-007-080