



# DB SERIES

## MODELS DB3, DB4, DB5



### DB3/4/5 PERFORMANCE 3450 RPM

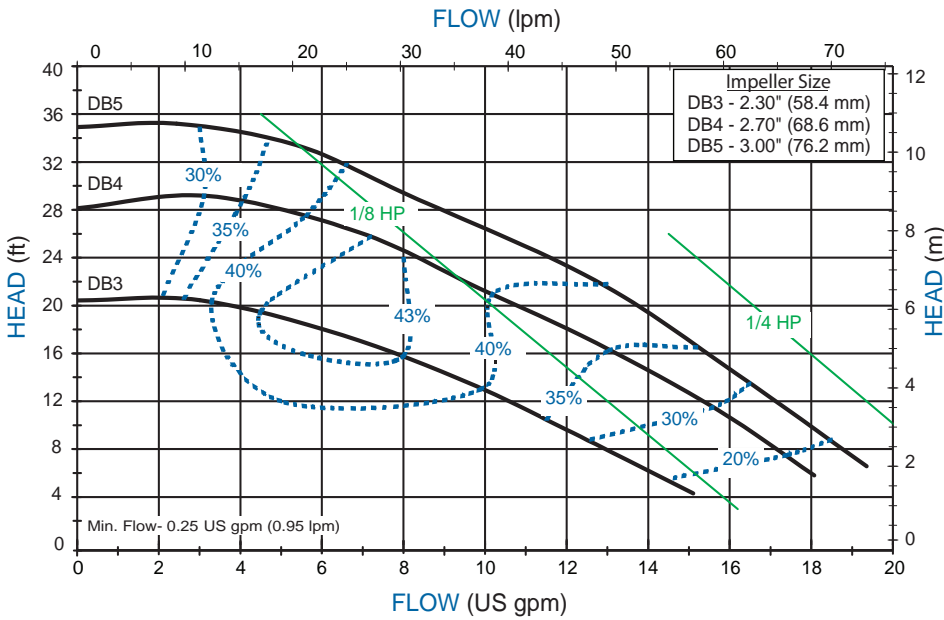

### DB3/4/5 PERFORMANCE 2900 RPM

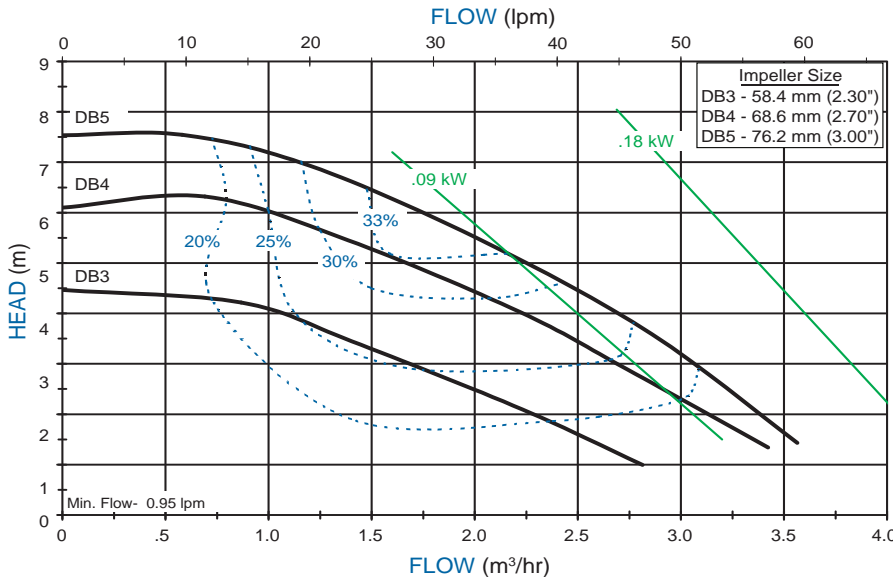

## FEATURES & CAPABILITIES

- + Five-year warranty
- + Extended run dry ability (with carbon bushing)
- + High operating efficiency
- + Polypropylene or PVDF construction
- + Powerful neodymium magnets
- + Close-coupled design
- + Threaded NPT or BSP connections
- + Horizontal or vertical installation
- + Back pullout design
- + Mounts to IEC 56, 63, & 71 B14 motor frames
- + Easy set, measurement free drive
- + CE certified
- + Working pressure to 60 psi (4.1 bar)
- + Specific gravity up to 1.8
- + Viscosity up to 150 cP
- + Polypropylene—180° F (82° C)
- + PVDF—220° F (104° C)

## APPLICATIONS

- + Chemical processing
- + Plating
- + Water and wastewater
- + Electronics
- + Pharmaceuticals
- + Wet scrubber
- + Pulp and paper
- + Heat exchanger
- + and many more!

# DB SERIES

## Specifications

Description	Polypropylene	PVDF
1 Impeller housing	Glass-fiber reinforced polypropylene (GF PP)	Carbon-fiber reinforced PVDF (CF PVDF)
1A Impeller housing thrust ring	High purity alumina ceramic	
2 O-ring	FKM or EPDM	
3 Impeller	GF PP and neodymium iron boron magnets encapsulated in unfilled polypropylene	CF PVDF and neodymium iron boron magnets encapsulated in unfilled PVDF
3A Impeller thrust ring	Glass-fiber molybdenum disulfide filled PTFE	
3B Bushing	Carbon, PTFE, high purity alumina ceramic	
4 Shaft	High purity alumina ceramic	
5 Barrier/Motor adapter	GF PP	CF PVDF
5A Barrier thrust ring	Silicon carbide	
6 Outer drive magnets	Nickel-plated neodymium iron boron magnets/ epoxy painted steel	

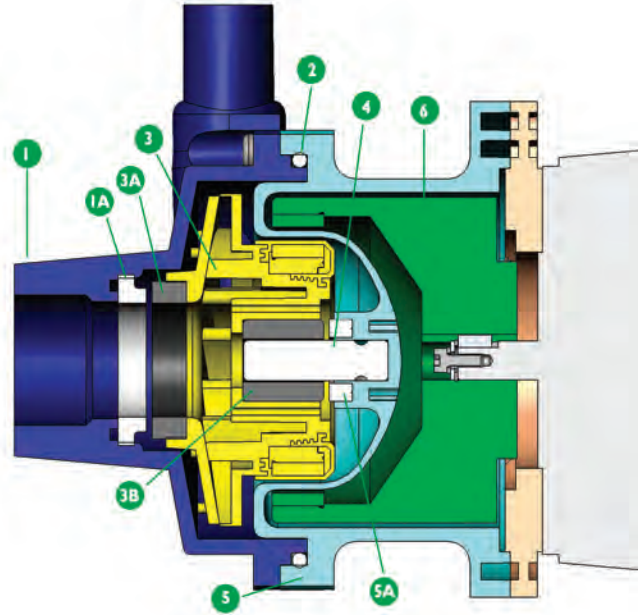

## Dimensions

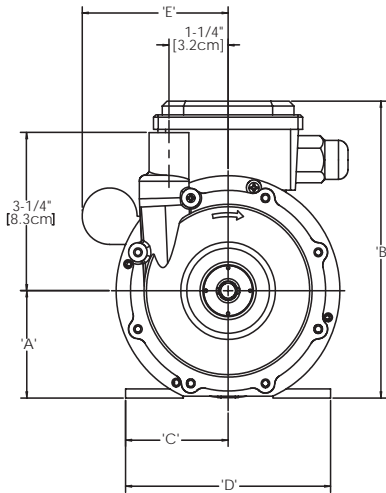

<sup>1</sup>Dimensions for K, L, and M can be found in the Outline Dimensions booklet in the Resources section of [www.finishthompson.com](http://www.finishthompson.com).

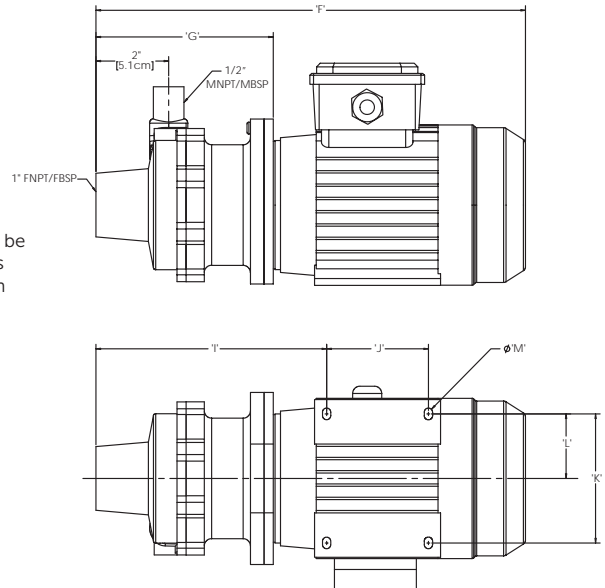

Motor Frame	A	B <sup>†</sup>	C	D	E	F	G	I	J	Weight - lbs. [kg]	
										PP	PVDF
IEC 56 w/B14	2-7/32" [5.6 cm]	6-1/8" [15.5 cm]	2-5/32" [5.5 cm]	4-5/16" [10.9 cm]	3-1/16" [7.8 cm]	11-3/4" [29.9 cm]	4-7/8" [12.4 cm]	6-5/16" [16.1 cm]	2-25/32" [7.1 cm]	3.7 [1.7]	4.05 [1.84]
IEC 63 w/B14	2-15/32" [6.3 cm]	6-5/16" [16 cm]	2-13/32" [6.1 cm]	4-13/16" [12.2 cm]	3-7/16" [8.7 cm]	12-7/8" [32.7 cm]	4-7/8" [12.4 cm]	6-5/8" [16.9 cm]	3-5/32" [8 cm]	3.7 [1.7]	4.05 [1.84]
IEC 71 w/B14	2-13/16" [7.1 cm]	7-7/16" [18.9 cm]	2-11/16" [6.9 cm]	5-13/32" [13.7 cm]	3-13/16" [9.7 cm]	14-1/16" [35.8 cm]	5-5/32" [13.1 cm]	6-15/16" [17.6 cm]	3-17/32" [9 cm]	3.9 [1.77]	4.35 [1.97]

Dimensions and weights are for reference only. Weights listed are for pump only; motor not included.

<sup>†</sup>Varies with motor manufacturer.