

**5700 SERIES
CONFINED SPACE
UNIT HEATER**
Horizontal or Vertical
Mounting

ATTENTION: Read carefully before attempting to install or operate Unit Heater.

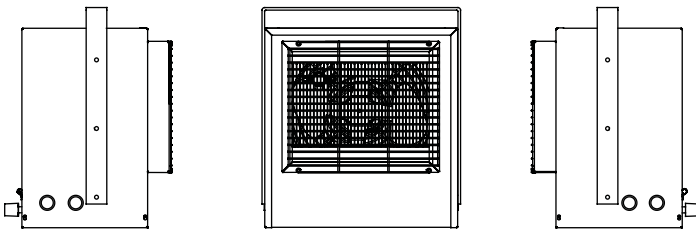
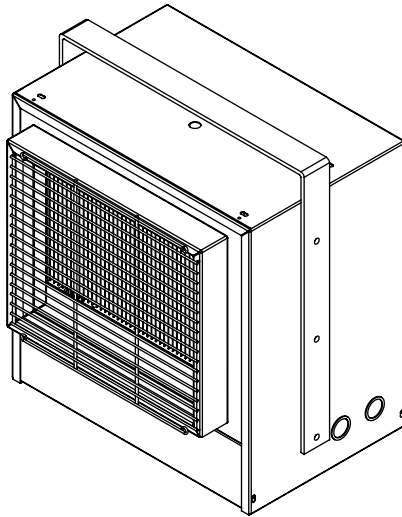

FEATURES:

- Forced air electric unit heater available in:
240/208 volt single phase, 5 kw
240 and 480 three phase 5 kw.
- 240/208 single phase unit is factory wired for 5 kw. The wattage may be changed by moving jumpers as indicated in table 1.
- 24 volt control standard or three phase unit.
- All units with "T" suffix provided with unit mounted hydraulic thermostat.
- Mounting bracket included with all units.

PROPER MOUNTING:

The heater(s) should be located along outside walls or other areas of greatest heat loss. Multiple heaters should be spaced to set up a generally circular air movement, each heater supporting the air stream of the other.

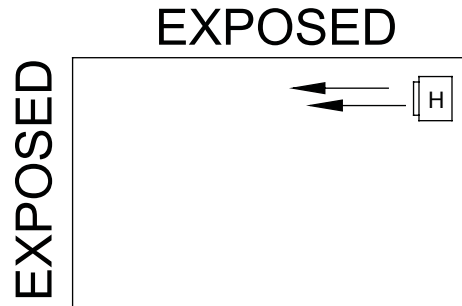
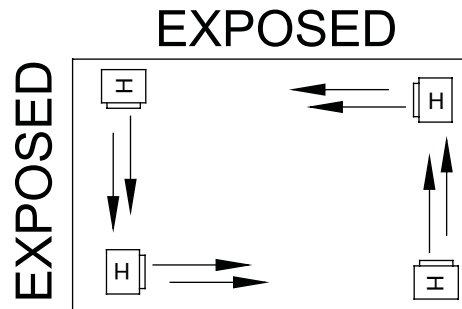

PRINCIPLES OF OPERATION

When the thermostat calls for heat, the elements are immediately energized, a fan delay brings on the fan after the elements are heated allowing warm air to circulate. When the thermostat is satisfied, the elements are de-energized and the fan purges the heater of residual heat.

The heater wattage may be field adjusted only on model HF5705T and HF5705TA . Select the desired wattage from Table 1 and move color coded jumpers as indicated.

WATTAGE ADJUSTMENT TABLE

VOLTS	WATTS	ADJUSTMENT
240/208	5000/3750	NONE REQUIRED
240/208	4167/3120	BLUE JUMPER TO TERMINAL 'C'
240/208	3333/2500	BLUE AND YELLOW TO TERMINAL 'C'
240/208	2500/1875	BLUE, YELLOW AND RED TO TERMINAL 'C'

USE COPPER CONDUCTORS ONLY
CONTROL CIRCUIT WIRING MUST BE
NEC CLASS 1 RATED 600 VOLT

TABLE 1

INSTALLATION INSTRUCTIONS

All electric unit heaters are shipped fully assembled. Installation includes hanging the unit and electrical wiring to the unit.

The wall and/or ceiling structure must be sufficient to support the combined weight of the heater and any mounting bracket and accessories.

Be sure power source is de-energized before installing heater. Check heater voltage and phase listed on heater data label on back of unit to make sure they are the same as the electrical service supplied.

MOUNTING THE HEATER

Select the mounting location. Be sure to observe the minimum mounting clearances as shown in Figure 1. The heater can be mounted either from the ceiling or wall depending on the application. The mounting bracket is supplied with 3/8" holes, 10 inches on center for threaded rod mounting or direct mounting to the structure. The heater cabinet also has 3/8" weld nuts 10" on center to allow threaded rod mounting without the bracket.

MOUNTING CONTINUED

1. Install the mounting bracket in the desired location with threaded rod or hardware that is appropriate for the mounting surface. If using threaded rod, two nuts, one on the top and one on the bottom of the bracket along with a split washer is suggested.
2. Secure the heater to mounting bracket, using the 1/4-20 x 3/4" machine screws and lockwashers provided.
3. Position the heater, aligning the bracket holes with the cabinet holes and secure bracket to the cabinet with the 1/4-20 x 1/2" machine screws and nuts that are provided. With the mounting bracket in the vertical position the 1/4" nuts are not necessary, weld nuts are supplied in the cabinet.

MINIMUM INSTALLATION CLEARANCES:

SIDES, TOP AND BOTTOM 0 INCHES

REAR: 8 INCHES (203mm)

FRONT: 24 INCHES (610mm)

Dégagements minimums MONTAGE:

Côtés, le haut et le bas 0 pouces

ARRIÈRE: 8 pouces (203mm)

AVANT: 24 pouces (610mm)

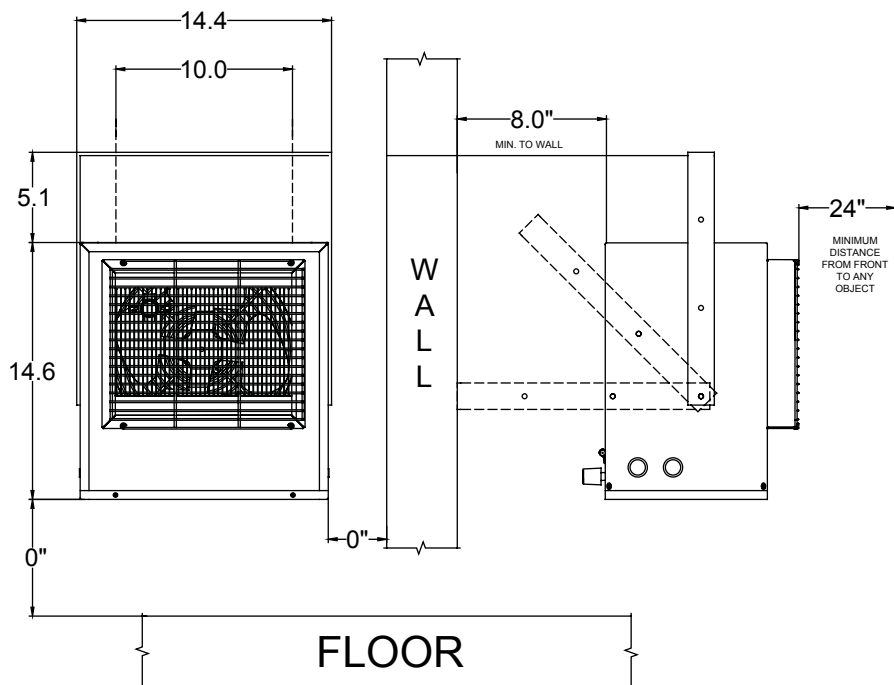

POWER CONNECTION

To avoid possible electrical shock, be sure the electrical current is turned off at the main switch prior to wiring or servicing of unit.

1. Remove the access panel, by removing four screws, two on the front and two on the back.
2. Remove desired knockout on side or back of the heater.
3. Following the correct unit wiring diagram, connect the power supply and electrical ground to the correct terminals using accepted practices recognized by local codes. See Table 2 for minimum circuit requirements.
4. Replace the access panel, tighten the screws to ensure a good seal to help prevent dust and dirt from entering the control compartment.

TECHNICAL DATA TABLE 2					
MODEL	VOLTS	WATTS	PHASE	AMPS	SUPPLY WIRE
HF5705T	240/208	5000/3750	1	20.83 / 18	10
H3H5705T	240/208	5000/3750	3	12.04/10.4	12
P3P5705T	480	5000	3	6.1	14
HF5705TA	240/208	5000/3750	1	20.83 / 18	10

Note: Supply wire must be 60° AWG minimum.

OPERATION

1. Restore power to the unit.
2. Turn the thermostat up to energize the unit. When the area reaches the desired temperature, rotate the thermostat knob counter- clockwise slowly until the heat turns off.
3. This 5700 series is provided with a fan delay/purge. When the heater is turned on, the elements will heat up before the fan comes on (approx. 30 seconds). This allows for warm air circulation. When the thermostat is satisfied, the elements will de-energize and the fan will continue to run (approx. 30 seconds) allowing residual heat to be purged from the heater.
4. The 5700 series is provided with an automatic limit control. In the event of an abnormal situation such as fan failure or other over-temp. situations the limit control will cycle the heater off. In the event of an over-temp situation, the heater should be inspected to determine the cause and repaired by authorized personnel.

Maintenance:

Caution: Make certain that the power source is disconnected before attempting to service or disassemble any component. If the power disconnect is out of the line of sight, lock it in the OPEN position and tag to prevent the application of power.

Electrical:

Once a year inspect the control panel wiring to make certain insulation is intact and all connections are tight. Inspect all heater and relay contacts. If the contacts appear badly pitted or burned, replace the contactor/relay.

Cleaning:

Clean the unit casing, fan and motor once a year. A dirty motor will tend to run hot and eventually will be damaged internally. Any rust spots on the casing should be cleaned and repainted. The element can be cleaned by removing the outer cabinet. Do not use any liquid to clean electric components.

Lubrication:

All units have fan motors that are permanently lubricated so that only occasional cleaning is required.

General Safety Information:**CAUTION:**

Follow all local electrical and safety codes, as well as the National Electric Code (NEC) and the Occupational Safety and Health Act (OSHA).

To avoid possible electrical shock, be sure the electrical current is turned off at the main switch prior to wiring or servicing of unit.

If the power disconnect is not integral and is out-of-sight, lock it in the open position and tag to prevent unexpected application of power prior to performing any service of maintenance on the unit.

The unit when installed must be electrically grounded in accordance with the National Electrical Code and standard industry practice.

Make certain that the power source conforms to the requirements of your equipment. See Table 2 for information as to wire and circuit size.

Check heater voltage and phase on rating label to confirm it is the same as the electric service supply.

Wiring diagrams of the heaters and supply connections are permanently attached to the heater access door. All terminals are coded in accordance with the wiring diagram.

The wall/ceiling mounting structure and anchoring provisions must be of sufficient strength to support the combined weight of the heater and mounting bracket.

