

R8140

REED INSTRUMENTS

LED Light Meter



Instruction
Manual

www.REEDINSTRUMENTS.com

Table of Contents

Introduction	3
Product Quality.....	3
Safety	3
Features.....	3
Included.....	3
Specifications	4
Instrument Description	5
Display Description	5
Application Notes and User Tips.....	6
<i>Protective Cap</i>	6
<i>Adjustable Sensor</i>	6
Operating Instructions.....	6-8
<i>Power On/Off (Automatic Zero Adjustment)</i>	6
<i>Unit of Measure Selection</i>	7
<i>Measurement Range Selection</i>	7
<i>Data Hold</i>	7
<i>MIN/MAX</i>	7
<i>Auto Power Off</i>	8
<i>Backlight</i>	8
<i>Selecting the Appropriate Light Setting</i>	8-9
Characteristics of Sensor Spectrum Response	9
Battery Replacement.....	9
Applications.....	10
Product Care	10
Product Warranty	10
Product Disposal and Recycling	11
Product Support.....	11

Introduction

Thank you for purchasing your REED R8140 LED Light Meter. Please read the following instructions carefully before using your instrument. By following the steps outlined in this manual your meter will provide years of reliable service.

Product Quality

This product has been manufactured in an ISO9001 facility and has been calibrated during the manufacturing process to meet the stated product specifications.

Safety

Never attempt to repair or modify your instrument. Dismantling your product, other than for the purpose of replacing batteries, may cause damage that will not be covered under the manufacturer's warranty. Servicing should only be provided by an authorized service center.

Features

- Measures ambient light levels of white, red, yellow, green and blue LED light and visible light in Foot-candles or Lux
- Large, backlit LCD display
- Detachable and rotatable light sensor
- Min/Max and data hold functions
- Cosine and color corrected measurements
- User adjustable parameter for specialized light sources
- Low battery indicator and auto shut off

Included

- Detachable Sensor
- Sensor Cover
- Hard Carrying Case
- Batteries

Specifications

Measuring Range(s):	Lux: 0 to 199,900 Fc: 0 to 19,990
Accuracy:	Incandescent Light Source: $\pm(3\% \text{ rdg.} + 5 \text{ dgt})$ Other Visible Light Source: $\pm 8\% \text{ rdg.}$
Resolution:	Lux: 0.1 Fc: 0.01
Response Time:	500mS
Sensor Type:	Silicon photodiode with color correction filter and cosine correction
Light Types:	White LED, Yellow LED, Green LED, Red LED, Blue LED, Warm White Fluorescent, Cold White Fluorescent Lamp, Incandescent
Angle deviation from cosine characteristics:	$10^\circ \pm 1\%$ $30^\circ \pm 2\%$ $60^\circ \pm 5\%$ $80^\circ \pm 20\%$
Autoranging:	Yes (Auto and Manual)
Display:	6-digit LCD
Backlit Display:	Yes
Data Hold:	Yes
Min:	Yes
Max:	Yes
Overrange Indicator:	Yes
Auto Shut-off:	Yes (after 30 minutes)
Low Battery Indicator:	Yes
Power Supply:	2 x AA Batteries
Battery Life:	Approx. 80 hours
Product Certifications:	CE, RoHS
Operating Temperature:	32 to 104°F (0 to 40°C)
Storage Temperature:	14 to 122°F (-10 to 50°C)
Operating Humidity Range:	0 to 80%
Dimensions:	6.7 x 2.5 x 1.5" (169 x 63 x 37mm)
Weight:	7.4oz (210g)

Instrument Description

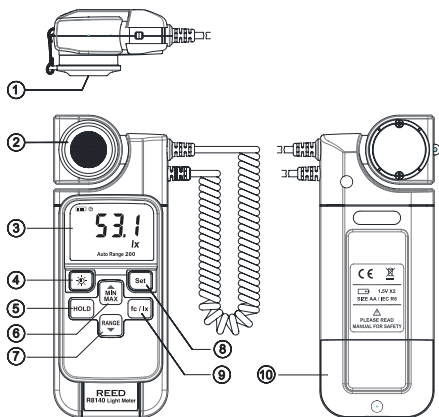

- | | |
|---------------------------|--------------------------------|
| 1. Protective Cap | 6. MIN/MAX/UP Button |
| 2. Light Sensor | 7. Range Selection/Down Button |
| 3. LCD Display | 8. Set Button |
| 4. Power/Backlight Button | 9. Fc/Lx Selector Button |
| 5. HOLD Button | 10. Battery Cover |

Display Description

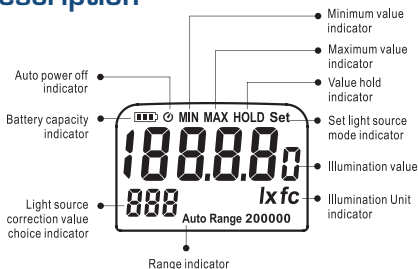

Application Notes and User Tips

1. Protective Cap

The protective cap used to protect the light sensor from damage and creates a complete dark environment for the meter to self-calibrate on start-up. When the meter is not in use, please keep the protective cap in place over the light sensor. This will prolong the life of the sensor.

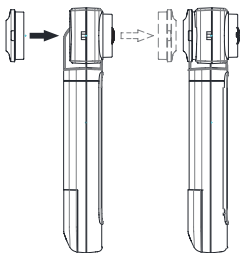

2. Adjustable Sensor

Depending on the application, the light sensor can be adjusted or removed from the meter. For maximum accuracy, allow the light under test to fall directly on the sensor as perpendicular as possible to avoid any false readings.

Note: Do not expose this meter to areas of high temperature and humidity.

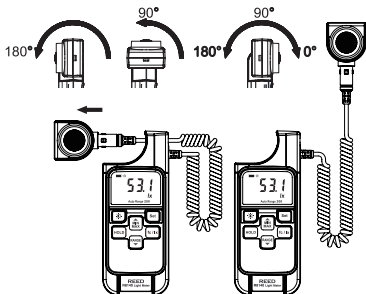

Operating Instructions

Power On/Off (Automatic Zero Adjustment)

1. Push the Power Button to turn the meter on. To turn the meter off, press and hold the power button during the countdown cycle from 3 to 0.
2. When turning the meter on it will perform an automatic zero adjustment as indicated by "CAP-" on the LCD display.

Note: Keep the protective cap on the sensor during the automatic zero adjustment. If "ERR1" appears, check the protective cap to insure it is properly secured.

3. After "CAL-" appears, the meter automatically adjusts to zero.
4. When automatic zero adjustment is completed, "CAL-" disappears and "0.0" will now appear on the LCD display, confirming that the cap can be removed to start testing.

continued...

Unit of Measure Selection

Press the **fc/lx** button to toggle between Foot Candles and Lux units of measurement. Refer to "Selecting the Appropriate Light Setting" section for information on the meter's pre-set correction settings according to the light source under test.

Note: 1fc=10.76lx

Measurement Range Selection

Press the **RANGE** button to select the preferred measuring range. The available ranges are: AUTO, 200, 2000, 20000, 200000 lx / AUTO, 20, 200, 2000, 20000 fc.

Data Hold

1. While taking a measurement, press the **HOLD** button to freeze the current readings on the display.
2. While in this mode a "HOLD" symbol will appear.
3. Press the button again to resume normal operation.

MIN/MAX

1. Press the **MIN/MAX** button to enter the MIN/MAX function.
2. The "MAX" indicator will appear on the display.
3. Under this function the maximum light value is displayed and updated when a new maximum data value has been taken.
4. Press the **MIN/MAX** button again and the "MIN" indicator will appear on the display.
5. Under this function the minimum light value is displayed and updated when a new minimum data value has been taken.
6. Press the **MIN/MAX** button a third time and both the "MIN & MAX" indicators will blink continuously.
7. Under this function the maximum & minimum values will continue to be updated in the memory while displaying the current light value.
8. To exit the MIN/MAX function, press and hold the **MIN/MAX** button for three seconds.

continued...

Auto Power Off

1. To preserve battery life, the meter is programmed to turn itself off after 30 minutes of inactivity.
2. To turn this function off, press and hold the **HOLD** button while powering on the meter.
3. Release both buttons simultaneously.
4. The Auto Power Off indicator will not appear on the display at start up, confirming this feature is now disabled.
5. If the meter is turned off then back on, the "Auto Power Off" feature will be enabled again.

Backlight

Press the Backlight Button to turn the LCD Backlight on and off. The backlight will automatically turn off after 30 seconds in order to preserve battery power.

Selecting the Appropriate Light Setting

The meter has been pre-loaded with 9 light source selections (L0-L8) each having its own unique correction factor. See the light sources listed below. The correction factor multipliers for L0-L7 are fixed to the specific light sources listed, whereas, L8 is a customizable location which allows you to set your own correction factor if a high precision light meter with "V()" <3% is available.

In order to select the appropriate setting, press the **Set** button and press the **▲** and **▼** buttons to toggle through the list of light sources. When the appropriate light source has been selected, press the **Set** button again to confirm your selection and resume normal operation.

Light Sources:

- L0: Standard incandescent light source
- L1: LED white daylight (5000K)
- L2: LED AMBER (YELLOW) light (3000K)
- L3: LED GREEN light
- L4: LED RED light
- L5: LED BLUE light
- L6: Warm White Fluorescent Lamp (4000K)

continued...

L7: Cold White Fluorescent Lamp (6500K)

L8: User setup mode

Characteristics of Sensor Spectrum Response

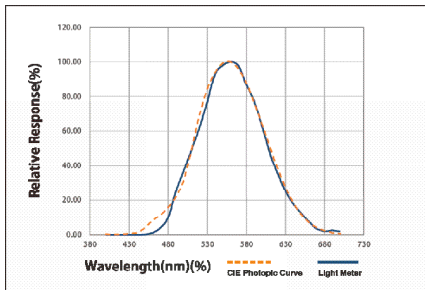

Battery Replacement

When the low battery icon appears on the LCD display, you will need to replace the batteries. In order to replace the batteries, proceed with the following steps.

1. Turn off the meter.
2. Remove the Phillips-head screw located on the battery compartment.
3. Remove the battery cover.
4. Replace the 2 x "AA" batteries.
5. Reinstall the battery cover.

Applications

- OSHA work environment compliance
- Cinematography and photography applications
- Museum exhibits
- Lighting system installation
- Environmental monitoring
- Interior design projects
- Industrial applications

Product Care

To keep your instrument in good working order we recommend the following:

- Store your product in a clean, dry place.
- Change the battery as needed.
- If your instrument isn't being used for a period of one month or longer please remove the battery.
- Clean your product and accessories with biodegradable cleaner. Do not spray the cleaner directly on the instrument. Use on external parts only.

Product Warranty

REED Instruments guarantees this instrument to be free of defects in material or workmanship for a period of one (1) year from date of shipment. During the warranty period, REED Instruments will repair or replace, at no charge, products or parts of a product that proves to be defective because of improper material or workmanship, under normal use and maintenance. REED Instruments total liability is limited to repair or replacement of the product. REED Instruments shall not be liable for damages to goods, property, or persons due to improper use or through attempts to utilize the instrument under conditions which exceed the designed capabilities. In order to begin the warranty service process, please contact us by email at 1-877-849-2127 or info@reedinstruments.com to discuss the claim and determine the appropriate steps to process the warranty.

Product Disposal and Recycling



Please follow local laws and regulations when disposing or recycling your instrument. Your product contains electronic components and must be disposed of separately from standard waste products.

Product Support

If you have any questions on your product, please contact your authorized REED distributor or REED Instruments Customer Service by phone at 1-877-849-2127 or by email at info@reedinstruments.com.

Please visit www.REEDINSTRUMENTS.com for the most up-to-date manuals, datasheets, product guides and software.

*Product specifications subject to change without notice.
All rights reserved. Any unauthorized copying or reproduction of this manual is strictly prohibited without prior written permission from REED Instruments.*

REED

INSTRUMENTS

TEST & MEASURE WITH CONFIDENCE



CHECK OUT OUR LATEST PRODUCTS!

www.REEDINSTRUMENTS.com