



REFERENCE DRAWINGS

PEDESTAL ASSEMBLY	9912-610-001
MXTP VALVE ADJUSTMENT	9912-252-002
(-SO) (24VAC)	9912-531-003
(-SO-BAT) (9VDC)	9927-221-005
SPRAY NOZZLES	9971-030-001
MULTI-PURPOSE WRENCH	9951-000-001

PRODUCT ROUGH-IN AND INSTALLATION REQUIRES THE FOLLOWING MATERIALS, NOT SUPPLIED BY ACORN ENGINEERING COMPANY.

- 3/4" NPT SUPPLIES TO VALVE ASSEMBLY (1/2" NPTE INLETS)
- 1-1/2" P-TRAP, DRAIN LINE AND WASTE FITTINGS
- SUITABLE FLOOR AND WALL ANCHORS FOR FIXTURE MOUNTING

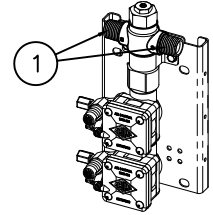
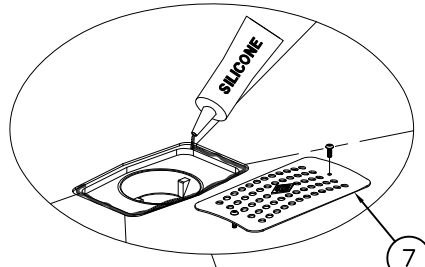

VALVE DETAIL
SCALE 2X

NOTE:
HAND OF VALVE SHOWN
FOR REFERENCE ONLY

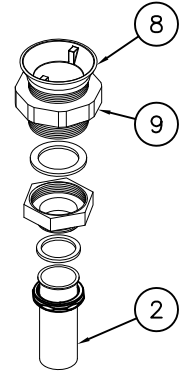
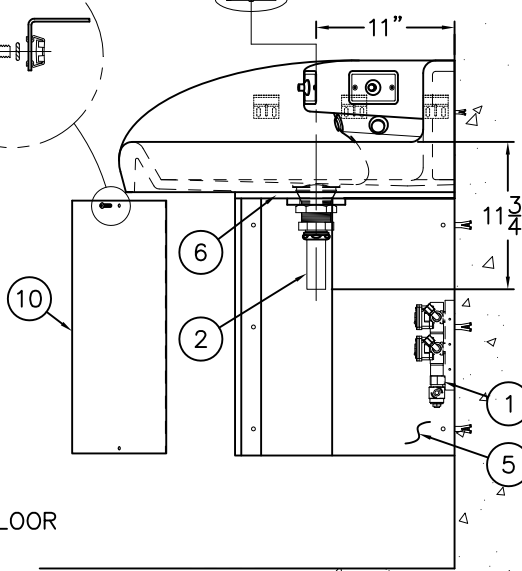
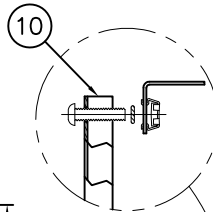
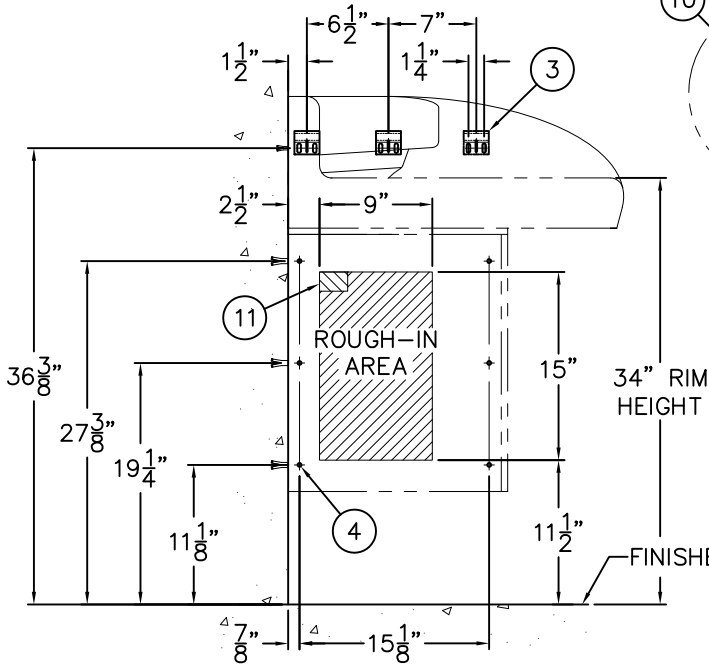

DRAIN ASSEMBLY
SCALE 2X

NOTE: WALL FASTENER DIMENSIONS ARE TYPICAL OF BOTH WALLS. SUPPLY AND WASTE CAN BE ON EITHER WALL (SHOWN ON RIGHT SIDE WALL).

ROUGH-IN FOR THE FOLLOWING:

- HOT & COLD SUPPLIES FOR MIXING VALVE WITH 1/2" NPTE VALVE INLETS (1).
- BASIN WASTE: 1-1/2" O.D. TAILPIECE (2) FOR P-TRAP ASSEMBLY BY OTHERS.
- FIXTURE ANCHORING: 1/4" UNC WALL FASTENERS (3) AND 3/8" UNC WALL FASTENERS (4) FOR ANCHORS BY OTHERS AND SUITABLE WALL BACKING BY OTHERS.

INSTALLATION INSTRUCTIONS:

- A- ASSEMBLE INSTALL PEDESTAL (5) PER DRAWING #9912-610-001.
- B- APPLY A BEAD OF SILICONE ADHESIVE TO THE TOP OF PEDESTAL SIDE PANELS (6). ENGAGE MOUNTED S-CLIPS (3) WITH BOTTOM BASIN MOUNTING CHANNEL WHILE ALIGNING TOP PEDESTAL MOUNTING POINTS AND SECURE WITH HARDWARE PROVIDED.
- C- REMOVE STRAINER (7) AND INSTALL DRAIN SPUD ASSEMBLY (8) TO BOWL USING PLUMBERS PUTTY AND THREAD LOCKNUT (9) ONTO SPUD.

- D- MAKE UP INSTALLER PROVIDED WASTE CONNECTIONS TO TAILPIECE (2) PROVIDED.
- E- FLUSH SUPPLY LINES PRIOR TO MAKING UP CONNECTIONS TO 1/2" NPTE VALVE INLET (1) CONNECTIONS.
- F- ADJUST MIXING VALVE TO DESIRED TEMPERATURE. REFER TO DRAWING 9912-252-001.
- G- SET TIMING CYCLE ON METERING VALVES; SEE DRAWING 9905-006-001 FOR DETAILS AND INSTRUCTIONS.
- H- INSTALL PEDESTAL ACCESS COVER (10) SEE DETAIL.

NOTE: REFER TO A.D.A. ACCESSIBILITY GUIDELINES FOR COMPLETE INSTALLATION REQUIREMENTS.

- OPTIONAL -SO SENSOR OPERATION: SUPPLY (11) 120VAC, 60 HZ, 3A MAX POWER TO FACTORY INSTALLED TRANSFORMER WITH JUNCTION BOX. LOCATE ELECTRICAL STUB OUT WITHIN SHADED ROUGH-IN AREA.
- TRANSFORMER MUST BE WIRED ONTO A GFI PROTECTED CIRCUIT. FIXTURE MUST BE EARTH GROUNDED PER N.E.C. (NATIONAL ELECTRICAL CODE).

ACORN ENGINEERING COMPANY
P.O. BOX 3527 Industry, CA 91744
15125 Proctor Ave Industry, CA 91746
(626) 336-4561 FAX (626) 961-2200

TITLE OFF-FLOOR CORTERRA CORNER LAV ROUGH-INS & BOWL ASSEMBLY 3622-1		
MANUFACTURE DATE JANUARY 2011 TO PRESENT	DATE ISSUED 01/25/11	DRAWING NUMBER 9912-601-002
	DATE REVISED 03/25/14 A	



REFERENCE DRAWINGS

PEDESTAL ASSEMBLY	9912-526-002
MXTP VALVE ADJUSTMENT	9912-252-002
(-SO) (9VAC)	9955-019-002
(-SO) (24VAC)	9955-015-002
SPRAY NOZZLES	9971-010-002
MULTI-PURPOSE WRENCH	9951-000-001

PRODUCT ROUGH-IN AND INSTALLATION REQUIRES THE FOLLOWING MATERIALS, NOT SUPPLIED BY ACORN ENGINEERING COMPANY.

- 3/4" NPT SUPPLIES TO VALVE ASSEMBLY (1/2" NPT INLETS)
- 1-1/2" P-TRAP, DRAIN LINE AND WASTE FITTINGS
- SUITABLE FLOOR AND WALL ANCHORS FOR FIXTURE MOUNTING

VALVE DETAIL

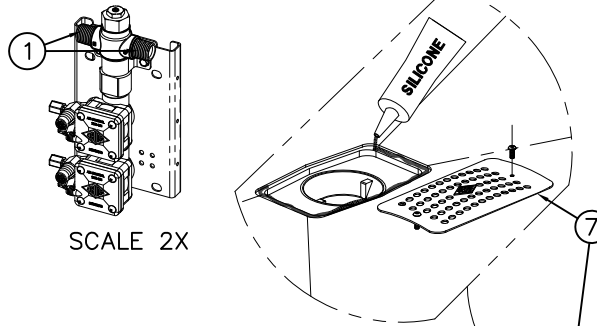

SCALE 2X

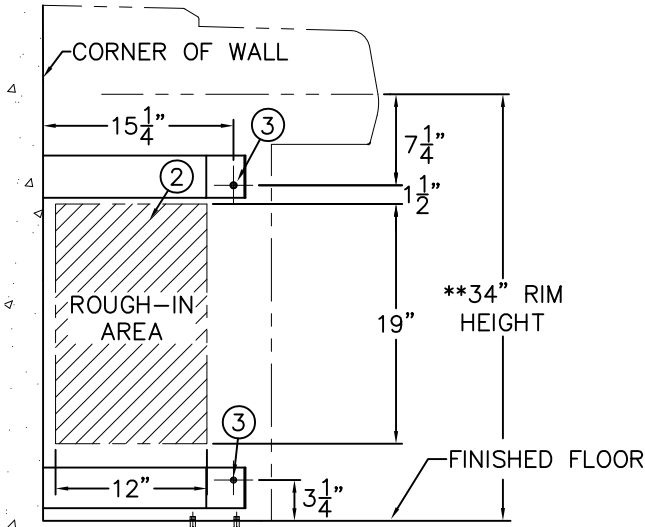

R.H. SIDE WALL SHOWN

NOTE: WALL FASTENER DIMENSIONS ARE TYPICAL OF BOTH WALLS. SUPPLY AND WASTE CAN BE ON EITHER WALL. (SHOWN ABOVE ON R.H. WALL SIDE).

DRAIN ASSEMBLY

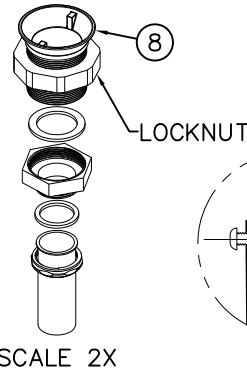

SCALE 2X

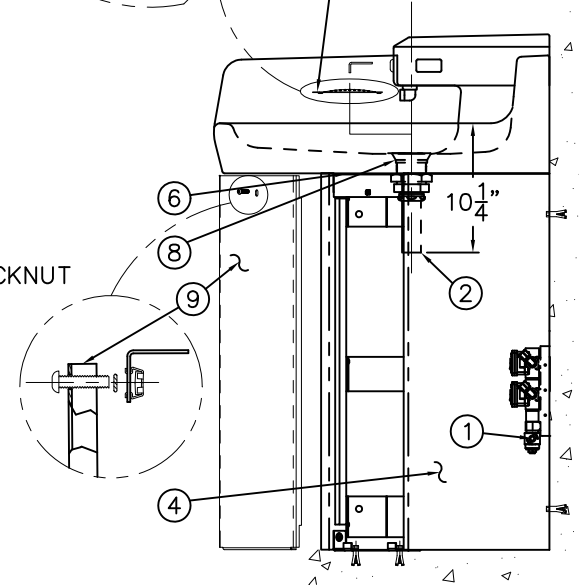

ROUGH-IN FOR THE FOLLOWING:

- HOT & COLD SUPPLIES FOR MIXING VALVE WITH 1/2" NPT VALVE INLETS (1).
- BASIN WASTE: 1-1/2" O.D. TAILPIECE (2) FOR P-TRAP ASSEMBLY BY OTHERS.
- FIXTURE WALL ANCHORING (3): 1/2"Ø PUNCHING FOR INSTALLER PROVIDED WALL ANCHORS AND ANCHORING HARDWARE.
- A- INSTALL PEDESTAL (4) PER #9912-526-002.
- B- APPLY A BEAD OF SILICONE ADHESIVE TO THE TOP OF PEDESTAL SIDE PANELS (6), AND ALIGN BASIN MOUNTING POINTS TO TOP CHANNEL MOUNTING POINTS AND SECURE WITH HARDWARE PROVIDED.
- C- ANCHOR FIXTURE TO WALL USING INSTALLER PROVIDED ANCHORING HARDWARE.
- D- REMOVE STRAINER (7) AND INSTALL DRAIN SPUD ASSEMBLY (8) TO BOWL USING PLUMBERS PUTTY AND THREAD LOCKNUT ONTO SPUD.
- E- MAKE UP INSTALLER PROVIDED WASTE CONNECTIONS TO TAILPIECE (2) PROVIDED.

- F- FLUSH SUPPLY LINES PRIOR TO MAKING UP CONNECTIONS TO 1/2" NPT VALVE INLET (1) CONNECTIONS.
- G- ADJUST MIXING VALVE TO DESIRED TEMPERATURE. REFER TO DRAWING 9912-252-001.
- H- SET TIMING CYCLE ON METERING VALVES; SEE DRAWING 9955-000-003 FOR DETAILS AND INSTRUCTIONS.
- I- INSTALL PEDESTAL ACCESS COVER (9) SEE DETAIL.

NOTE: REFER TO A.D.A. ACCESSIBILITY GUIDELINES FOR COMPLETE INSTALLATION REQUIREMENTS.

- UNITS WITH OPTIONAL -JH JUNIOR RIMHEIGHTS SUBTRACT DIFFERENCE FROM ALL VERTICAL DIMENSIONS INDICATED **.
- OPTIONAL -SO SENSOR OPERATION: SUPPLY 120VAC, 60 HZ, 3A MAX POWER TO FACTORY INSTALLED TRANSFORMER WITH JUNCTION BOX. LOCATE ELECTRICAL STUB OUT WITHIN SHADED ROUGH-IN AREA.
- TRANSFORMER MUST BE WIRED ONTO A GFI PROTECTED CIRCUIT. FIXTURE MUST BE EARTH GROUNDED PER N.E.C. (NATIONAL ELECTRICAL CODE).



ACORN ENGINEERING COMPANY
P.O. BOX 3527 Industry, CA 91744
15125 Proctor Ave Industry, CA 91746
(626) 336-4561 FAX (626) 961-2200

TITLE TERRAZZO-LAV ROUGH-INS & BOWL ASSEMBLY 3612		
MANUFACTURE DATE JANUARY 1991 TO PRESENT	DATE ISSUED 05/11/10	DRAWING NUMBER 9912-502-003
	DATE REVISED 03/25/14 A	

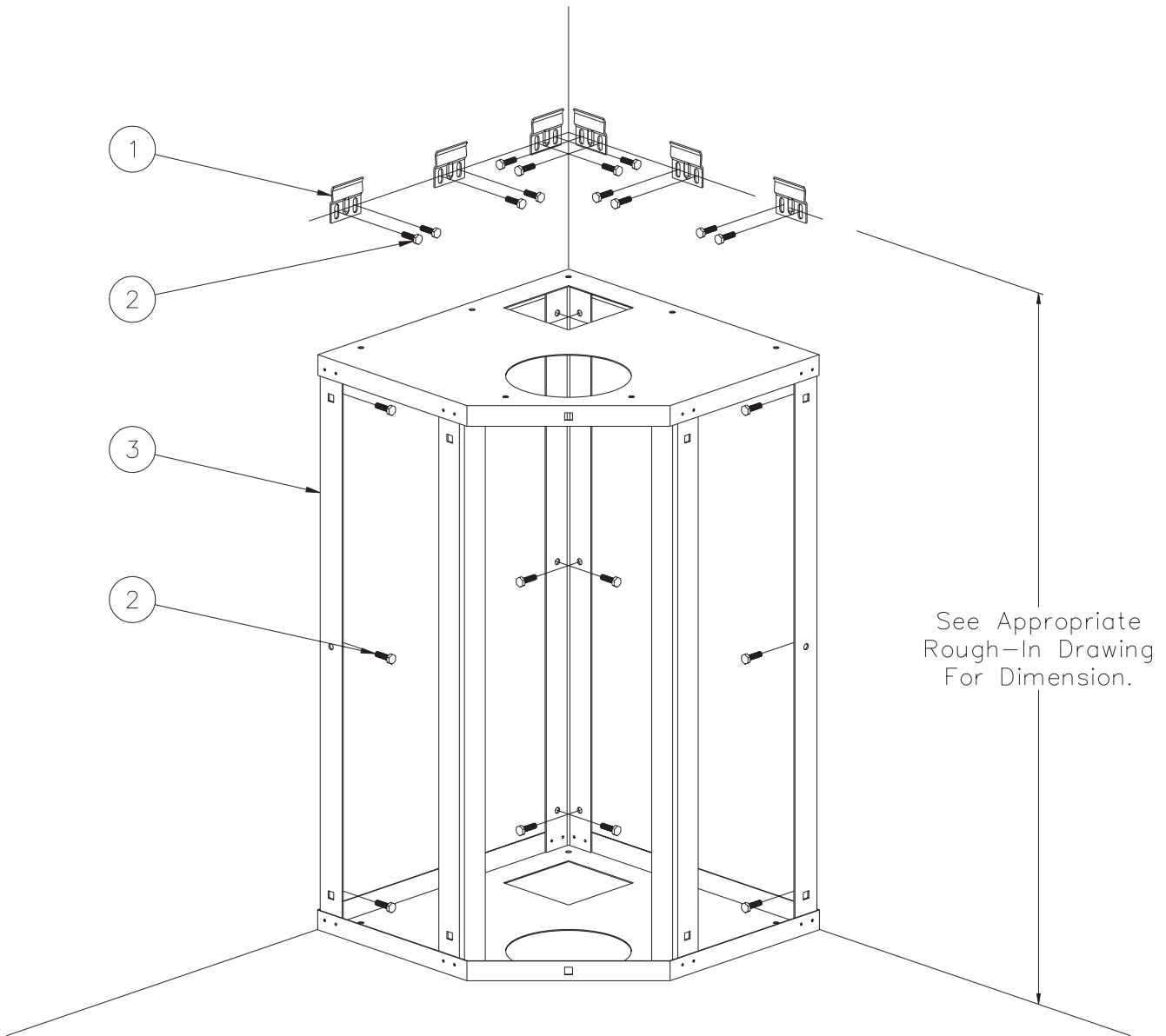

INSTALLATION INSTRUCTIONS:

A- See appropriate drawing for rough-in information. Install wall anchors, and make appropriate waste, valve, and electrical rough-ins.

- B- Anchor S-clips ① with wall anchoring hardware ② by others.
- C- Anchor pedestal assembly ③ with wall anchoring hardware ② by others.
- D- Installation instructions continue on drawing # 9912-611-001.



ACORN ENGINEERING COMPANY
 P.O. BOX 3527 INDUSTRY, CA. 91744
 (626) 336-4561 FAX (626) 961-2200

TITLE CORTERRA CORNER-LAV PEDESTAL INSTALLATION MODEL #3622		
MANUFACTURE DATE NOVEMBER 1999 TO PRESENT	DATE ISSUED 09/05/01	DRAWING NUMBER 9912-610-001
	DATE REVISED	

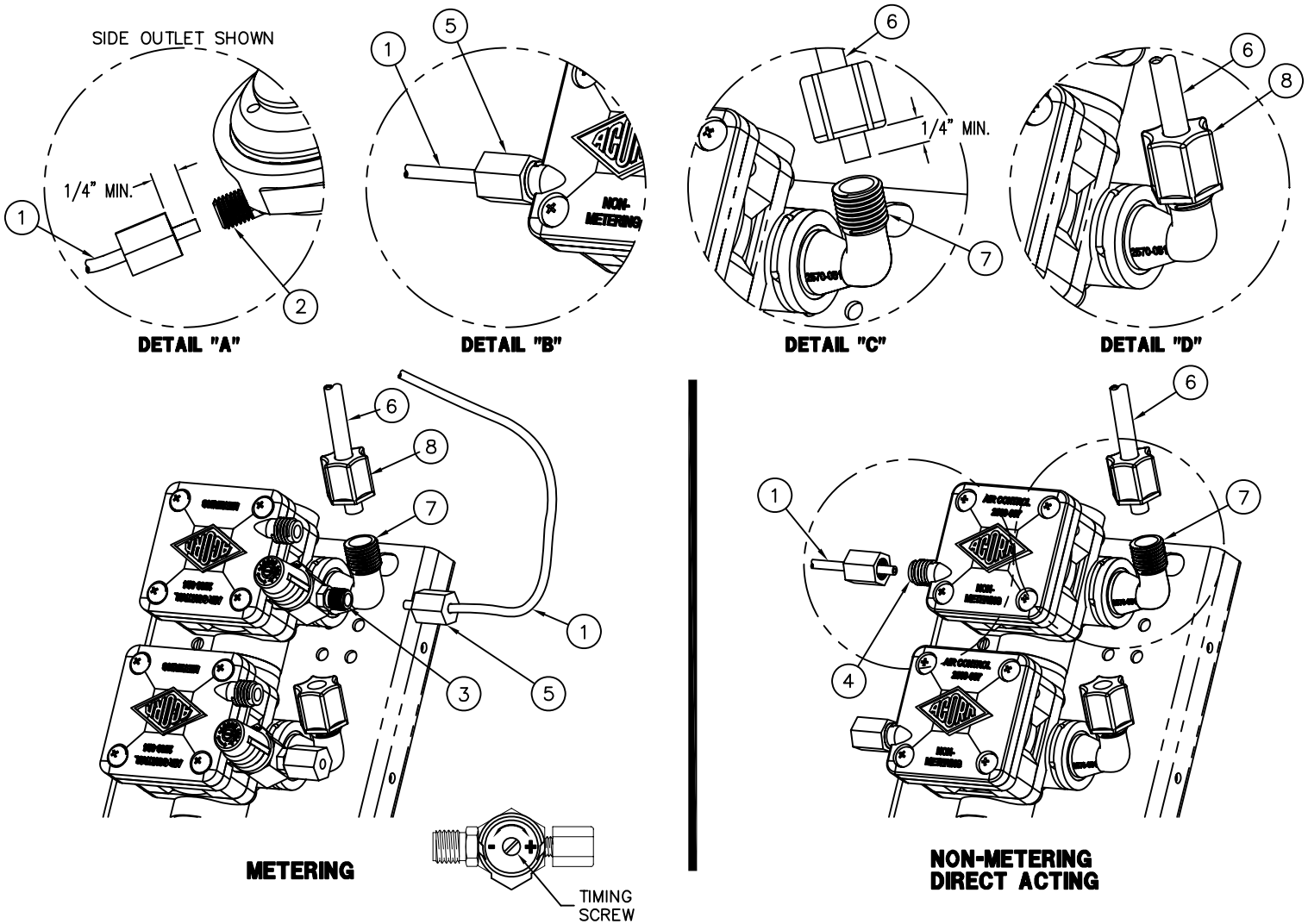

TIMING IS ADJUSTABLE FROM 5 TO 60 SECONDS AND IS ACCOMPLISHED BY ROTATING TIMING SCREW. TURNING THE SCREW CLOCKWISE INCREASES WHILE COUNTERCLOCKWISE DECREASES TIMING.

INSTALLATION INSTRUCTIONS:

- A- MOUNT FIXTURE IN ACCORDANCE TO MANUFACTURER'S INSTALLATION INSTRUCTIONS.
- B- ASSEMBLE SPOUTS AND PUSHBUTTONS TO FIXTURE.
- C- CONNECT 1/8" O.D. POLYETHYLENE AIR LINE ① TO PUSHBUTTON ②, AND VALVE TIMER ASSEMBLY ③ SEE DETAIL "A". NOTE: FOR DIRECT ACTING: ASSEMBLE TO AIR PORT ④, SEE DETAIL "B". HAND TIGHTEN FERRULE NUT ⑤ PROVIDED.
- D- CONNECT 1/4" O.D. POLYETHYLENE WATER LINES ⑥ TO VALVE ASSEMBLY ELBOW ⑦ SEE DETAILS "C", AND "D". HAND TIGHTEN FERRULE NUT ⑧ PROVIDED.
- E- AFTER THOROUGHLY FLUSHING SUPPLY LINES MAKE UP CONNECTIONS TO VALVE ASSEMBLY INLET(S) 1/2" NPT OR 1/2" NPS FLEX HOSE AS REQUIRED.

REFERENCE DRAWINGS	
ASSEMBLIES	DRAWING
VALVE BODY	9955-006-003
CHECKSTOP	9956-040-003
FIXTURE TRIM	9957-051-001
AIR-CONTROL SERVOMOTORS	
METERING	9955-000-003
NON-METERING	9955-001-003

NOTE:
 • ALL TUBING SHOULD BE CUT SQUARE AND BE FREE OF BURRS OR DEFORMITIES TO ENSURE A WATER TIGHT CONNECTION.
 • EXTEND TUBING AT LEAST 1/4" BEYOND FERRULE NUT BEFORE INSERTING TUBING INTO CONNECTION OPENING BEFORE TIGHTENING.
 • TUBING SHOULD BE FREE OF KINKS FOR PROPER OPERATION
 • MAXIMUM RECOMMENDED WORKING WATER PRESSURE IS 100 PSI; TEMPERATURE IS 130° F; OUTLET TEMPERATURE IS RECOMMENDED AT A MAXIMUM OF 105° F.
 WARNING:
 PRIOR TO MAKING INSTALLATION, SUPPLY LINES MUST BE FLUSHED OF ALL FOREIGN MATERIAL SUCH AS PIPE DOPE, CHIPS, SOLDER, ETC. VALVE MUST BE DRAINED PRIOR TO BEING SUBJECTED TO FREEZING TEMPERATURES. MAXIMUM RECOMMENDED OUTLET WATER TEMPERATURE IS 105° F.

ACORN ENGINEERING COMPANY P.O. BOX 3527 INDUSTRY, CA. 91744 (626) 336-4561 FAX (626) 961-2200	TITLE HAND OPERATED AIR CONTROL VALVE CONNECTIONS		
	MANUFACTURE DATE JANUARY 1999 TO PRESENT	DATE ISSUED 04/22/10	DRAWING NUMBER 9905-006-001
		DATE REVISED 10/11/10	



REFERENCE DRAWINGS		
REPAIR PARTS		DRAWING
NON-METERING SERVOMOTOR	(-F)	9955-001-003
METERING SERVOMOTOR	(-H)	9955-000-003
AIR-CONTROL VALVE BODY		9975-090-001
CHECKSTOP	(-ST Single Temp. Only)	9956-040-003
SENSOR/SOLENOID	(-SO) (24VAC)	9955-015-002
SENSOR/SOLENOID/PPZ	(-SO) (9VDC)	9955-019-002
HAND BUTTON		9957-300-001
FOOT BUTTON		9957-200-001

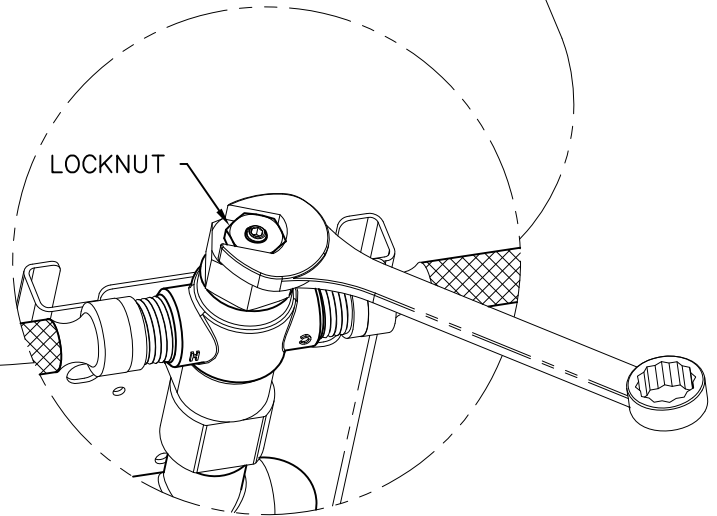
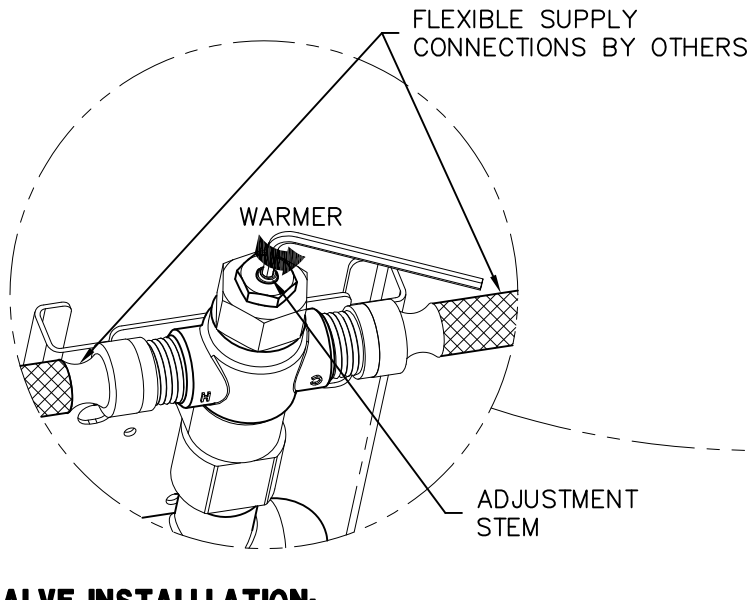
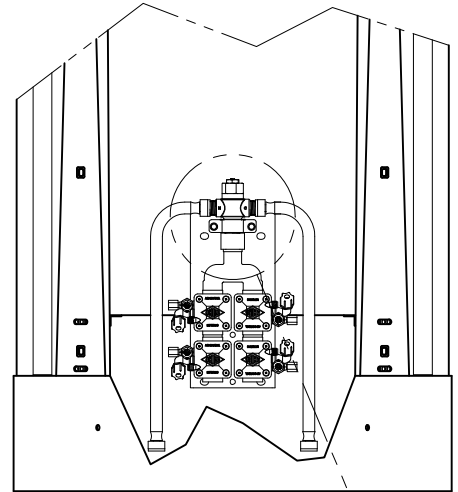

VALVE INSTALLATION:

- A- MX-T/P VALVES: AFTER THOROUGHLY FLUSHING SUPPLY LINES, MAKE UP CONNECTIONS TO SUPPLY STUB OUTS AND VALVE INLETS WITH INSTALLER PROVIDED FLEXIBLE HOSE. NOTE: MX-T/P VALVE SUPPLY INLETS ARE 1/2" NPT.
- B- OPTIONAL -ST (Single Temp): AFTER THOROUGHLY FLUSHING SUPPLY LINE, MAKE UP CONNECTION TO SUPPLY STUB OUT AND VALVE INLET WITH FLEXIBLE HOSE PROVIDED. NOTE: -ST VALVES INCLUDE FLEXIBLE HOSE WITH 1/2" NPSI CONNECTIONS. FLEXIBLE HOSE ENDS WILL ACCOMMODATE 1/2" NPT MALE ADAPTER.
- C- SEE APPROPRIATE SERVOMOTOR REFERENCE DRAWINGS FOR VALVE DETAILS AND TIMING INSTRUCTIONS.

MX T/P TEMPERATURE VALVE ADJUSTMENT

- D- LOOSEN LOCKNUT SHOWN.
- E- TURN ON FIXTURE AND RUN WATER FOR AT LEAST 2 MINUTES. ALLOW WATER TO STABILIZE.
- F- USE AN 1/8" ALLEN WRENCH TO TURN ADJUSTMENT STEM COUNTER-CLOCKWISE FOR WARMER OR CLOCKWISE FOR COOLER OUTLET WATER TEMPERATURE.
- G- TIGHTEN LOCKNUT TO PREVENT ACCIDENTAL OR UNAUTHORIZED TEMPERATURE ADJUSTMENT.
- H- RE-CHECK OUTLET TEMPERATURE.

ACORN ENGINEERING COMPANY P.O. BOX 3527 Industry, CA 91744 15125 Proctor Ave Industry, CA 91746 (626) 336-4561 FAX (626) 961-2200	TITLE VALVE INSTALL & MIXING VALVE ADJUSTMENT		
	MANUFACTURE DATE MARCH 2014 TO PRESENT	DATE ISSUED 03/25/14	DRAWING NUMBER 9912-252-002
	DATE REVISED		



TWO STATION WIRING DIAGRAM SHOWN

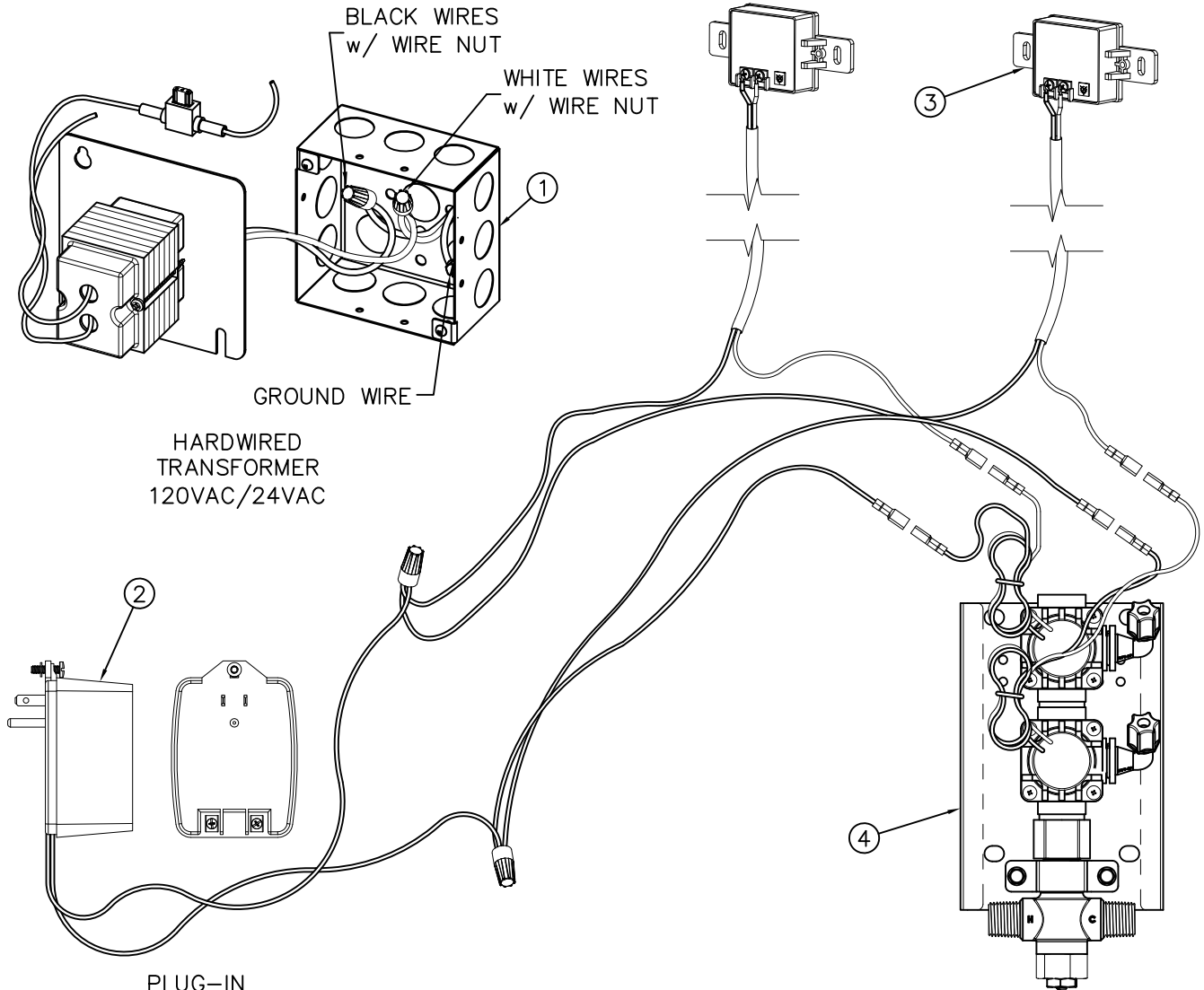

REFERENCE DRAWINGS	
24VAC SENSOR ADJUSTMENT	9940-011-001
24VAC SENSOR & HARDWARE	9955-015-002
24VAC SENSOR & MAINTENANCE	9940-010-002

INSTALLATION INSTRUCTIONS:

- A- REFER TO FIXTURE DRAWINGS FOR INSTALLATION & ROUGH-IN INFORMATION.
- B- PROVIDE 120VAC, 60Hz, 3 AMPS MAX, SERVICE TO CONNECT 24VAC, 50VA TRANSFORMER PLATE & J-BOX ①, OR RECEPTACLE FOR PLUG-IN TRANSFORMER ②. SEE NOTE.
- C- CONNECT WIRE SET FROM SENSOR ③ TO SOLENOID VALVE ④ AND TRANSFORMER ①, OR ②. CONNECT TRANSFORMER TO POWER SUPPLY.

- E- COMPLETE INSTALLATION OF FIXTURE PER FACTORY INSTALLATION SHEETS PROVIDED.

NOTE:

- 1- PLUG-IN TRANSFORMER INCLUDES BUILT-IN SECONDARY FUSE. IN THE EVENT OF POWER SURGE TRANSFORMER MAY REQUIRE REPLACEMENT.
- 2- ELECTRICAL RECEPTACLE MUST BE WIRED TO A GFI PROTECTED CIRCUIT. FIXTURE MUST BE EARTH GROUNDED PER N.E.C. (NATIONAL ELECTRICAL CODE).



ACORN ENGINEERING COMPANY
 P.O. BOX 3527 Industry, CA 91744
 15125 Proctor Ave Industry, CA 91746
 (626) 336-4561 FAX (626) 961-2200

TITLE 24VAC -SO SENSOR INSTALLATION INSTRUCTIONS		
MANUFACTURE DATE OCTOBER 2010 TO PRESENT	DATE ISSUED 05/10/10	DRAWING NUMBER 9912-531-003
	DATE REVISED 03/28/14 A	



NOTE: RANGE OF MOTION FOR ADJUSTMENT SCREW IS FROM APPROX. 8 O'CLOCK CLOCKWISE TO APPROX. 4 O'CLOCK.

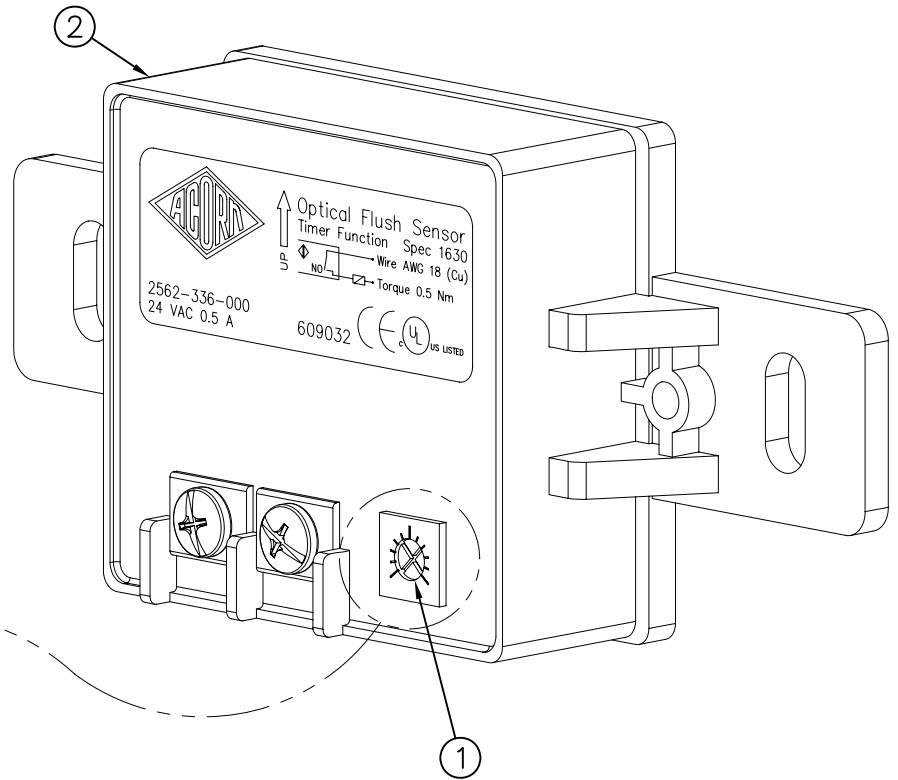

INCREASE

DECREASE

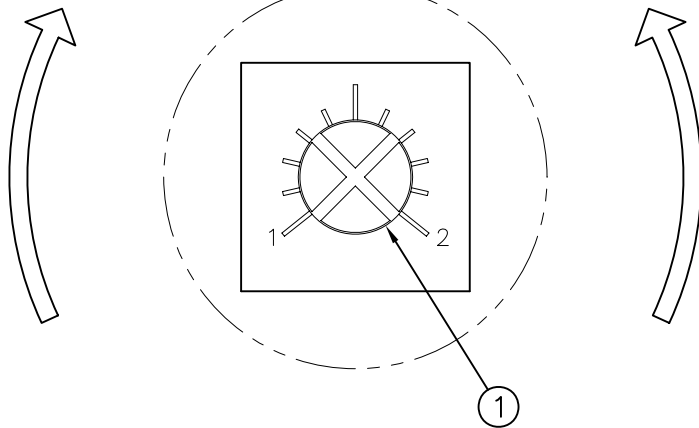

A- USE SMALL JEWELERS CROSS TIP SCREW DRIVER TO ADJUST SENSOR RANGE ① ON BACK OF SENSOR ②.

C- TURN ADJUSTMENT SCREW ① COUNTERCLOCKWISE TO DECREASE SENSOR RANGE.

B- TURN ADJUSTMENT SCREW ① CLOCKWISE TO INCREASE SENSOR RANGE.

D- NOTE: SENSOR RANGE IS FROM 0 TO APPROXIMATELY 24" MAXIMUM.



ACORN ENGINEERING COMPANY
P.O. BOX 3527 INDUSTRY, CA. 91744
(626) 336-4561 FAX (626) 961-2200

TITLE **24VAC SENSOR RANGE ADJUSTMENT**

MANUFACTURE DATE
**JUNE 2002
TO PRESENT**

DATE ISSUED
02/22/08
DATE REVISED
08/10/09

DRAWING NUMBER
9940-011-001



START UP MODE:

The Acorn -SO is a 24VAC sensor and includes a manual range adjustment. Sensor range adjustments may be made using adjustment screw on back of sensor.



The Start Up Mode will take approximately five (5) minutes to complete its full cycle and it is important that no target is present in front of the sensor during this time. A steady red light visible in the center of the oval sensor window indicates the sensor is in Start Up Mode. If the red light is flashing, this indicates that the sensor is picking up a target. Unless this target is a permanent fixture in the sensor's environment (i.e. a wall or stall door) it must be removed from the view of the sensor. If this target is permanent the sensor will attempt to adapt itself around this target. When Start Up Mode is complete the steady red light will go off.

NOTE:

1. If the 24VAC power supply is interrupted for more than fifteen (15) seconds the Start Up Mode will automatically repeat itself when the power is restored.
2. If the indicator light flashes three (3) times quickly, then three (3) times slowly and continues to repeat this sequence, this indicates incorrect wiring or a short in the 24VAC power supply.

NORMAL VALVE FUNCTION:

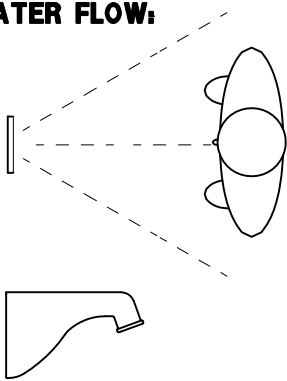
One second time delay when sensor is activated by user. Time of flow is 30 seconds. To reactivate, the user must move out of and return to the sensing area. When installed in the shower, flow continues indefinitely until user moves from sensing area.

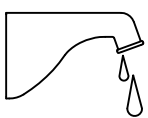
CONDITION:	PROBABLE CAUSE
<p>NO WATER FLOW:</p> 	<ol style="list-style-type: none"> 1.1 Stops or main water supply may be closed. 1.2 When using -T/P mixing valve, both supplies must be open to supply adequate water flow. 1.3 Clogged strainer. 1.4 Clogged water diaphragm. 1.5 Loose wiring connections. 1.6 Blown fuse at transformer. 1.7 Circuit breaker shut off.
<p>WATER WON'T SHUT OFF</p> 	<ol style="list-style-type: none"> 2.1 Adjacent objects may be triggering the sensor. 2.2 Sensor malfunction.
<p>WATER DRIPS</p> 	<ol style="list-style-type: none"> 3.1 Clogged water diaphragm.

MINIMUM / MAXIMUM WATER PRESSURE (PSI) 30 / 125. MAXIMUM WATER TEMPERATURE 130°F.

Refer to drawing #9955-016-002 for parts breakdown of items listed above.

Refer to Acorn Operations And Maintenance Manual for installation instructions and repair parts.

 <p>ACORN ENGINEERING COMPANY P.O. BOX 3527 Industry, CA 91744 15125 Proctor Ave Industry, CA 91746 (626) 336-4561 FAX (626) 961-2200</p>	TITLE		
	24VAC -SO SENSOR OPERATED VALVE MAINTENANCE INSTRUCTIONS		
	MANUFACTURE DATE	DATE ISSUED	DRAWING NUMBER
FEBRUARY 2012	02/09/12	9940-010-003	
TO PRESENT	DATE REVISED		



TWO STATION WIRING DIAGRAM SHOWN

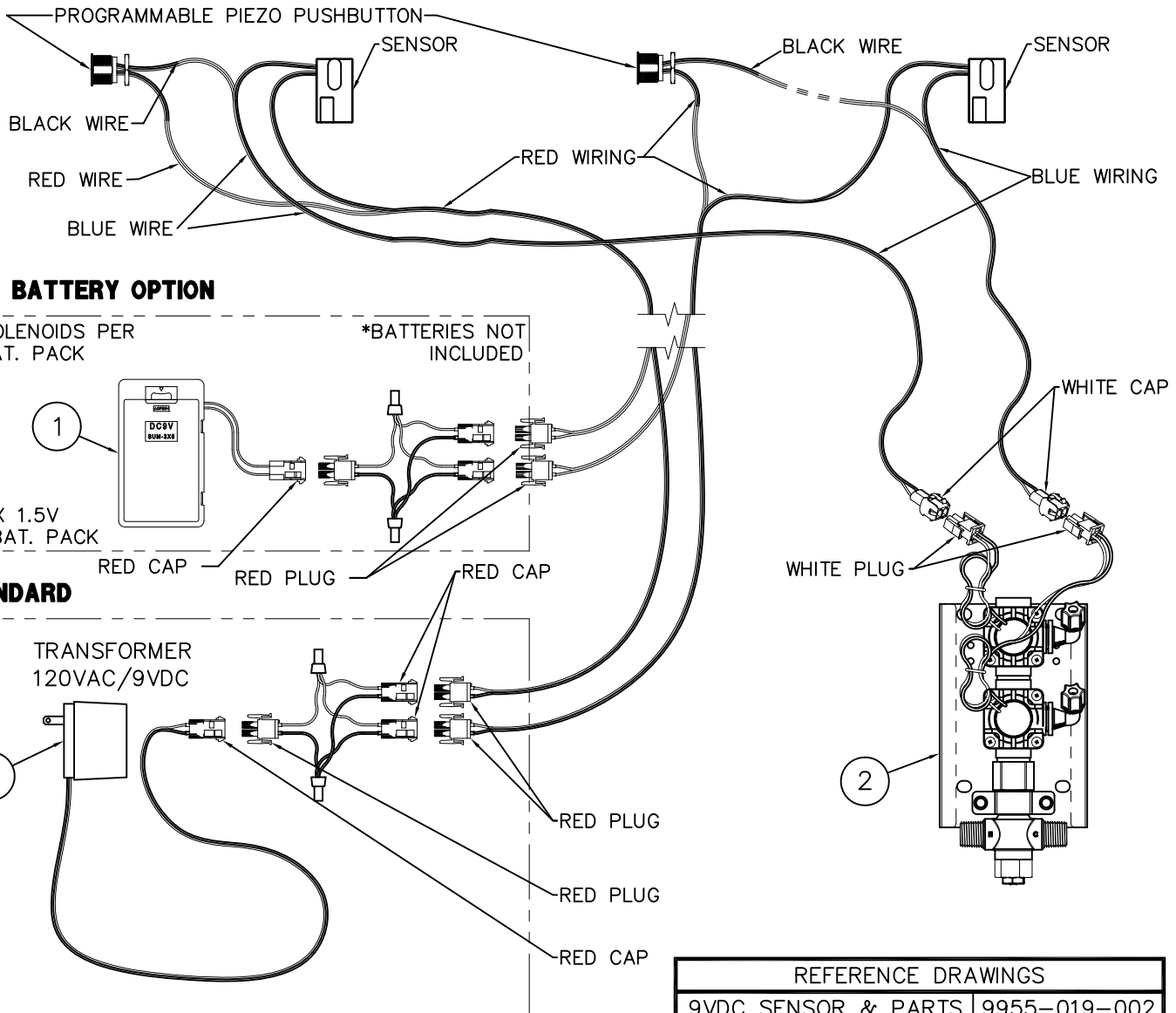

-BAT BATTERY OPTION

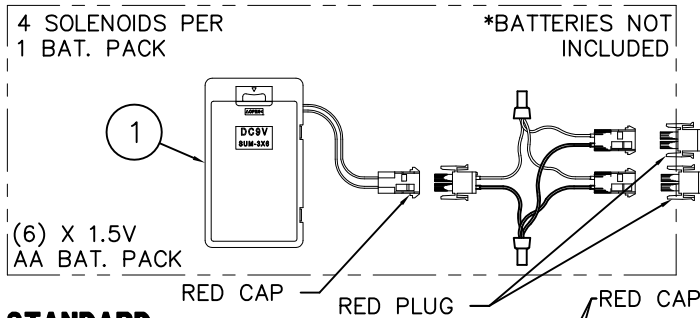

STANDARD

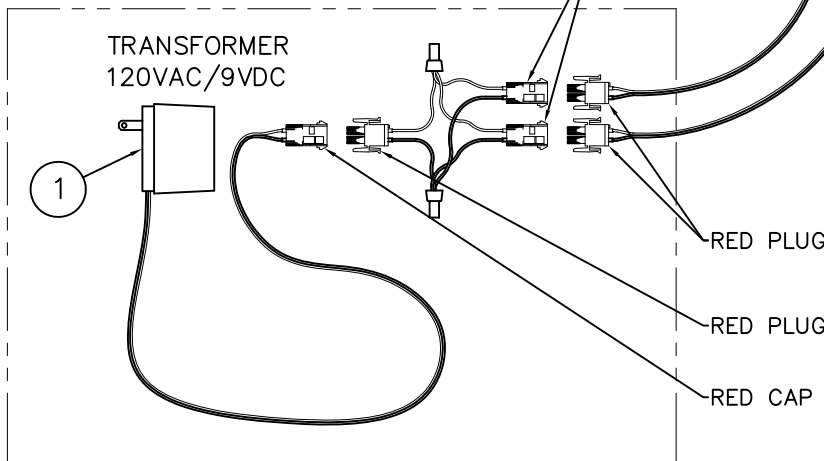

REFERENCE DRAWINGS	
9VDC SENSOR & PARTS	9955-019-002
PIEZO PB PROGRAMMING	9940-009-001

INSTALLATION INSTRUCTIONS:

- A- USING APPROPRIATE INSTALLATION INSTRUCTIONS, MOUNT FIXTURE TO WALL AND MAKE-UP WASTE PIPING CONNECTIONS. SENSOR OR ELECTRONIC PUSHBUTTON ARE FACTORY INSTALLED. POWER SUPPLY ① AND VALVE ② SHIPPED LOOSE.
- B- INSTALL SOLENOID VALVE ASSEMBLY ② ON THE WALL (FASTENERS AND WALL ANCHORS BY OTHERS), MAKING SURE THAT THE VALVE WILL BE WITHIN BOTTOM ENCLOSURE.
- C- CONNECT WATER SUPPLY (AFTER FLUSHING LINES) TO VALVE, AND VALVE RISER TO SPOUTS AS PER UNIT INSTALLATION INSTRUCTIONS.

- D- CONNECT SOLENOID VALVE, POWER SUPPLY AND SENSOR WIRING AS SHOWN ON DETAIL.
- E- COMPLETE THE INSTALLATION OF THE UNIT ACCORDING TO THE UNITS INSTALLATION INSTRUCTIONS.

NOTE:

- 1- PLUG-IN TRANSFORMER INCLUDES BUILT-IN SECONDARY FUSE. IN THE EVENT OF POWER SURGE TRANSFORMER MAY REQUIRE REPLACEMENT.
- 2- ELECTRICAL RECEPTACLE MUST BE WIRED TO A GFI PROTECTED CIRCUIT. FIXTURE MUST BE EARTH GROUNDED PER N.E.C. (NATIONAL ELECTRICAL CODE).



ACORN ENGINEERING COMPANY
P.O. BOX 3527 Industry, CA 91744
15125 Proctor Ave Industry, CA 91746
(626) 336-4561 FAX (626) 961-2200

TITLE -SO SENSOR/ -PPZ PIEZO ELECTRONIC PUSHBUTTON INSTALLATION		
MANUFACTURE DATE OCTOBER 2009 TO PRESENT	DATE ISSUED 09/06/13	DRAWING NUMBER 9927-221-005
	DATE REVISED 03/25/14	

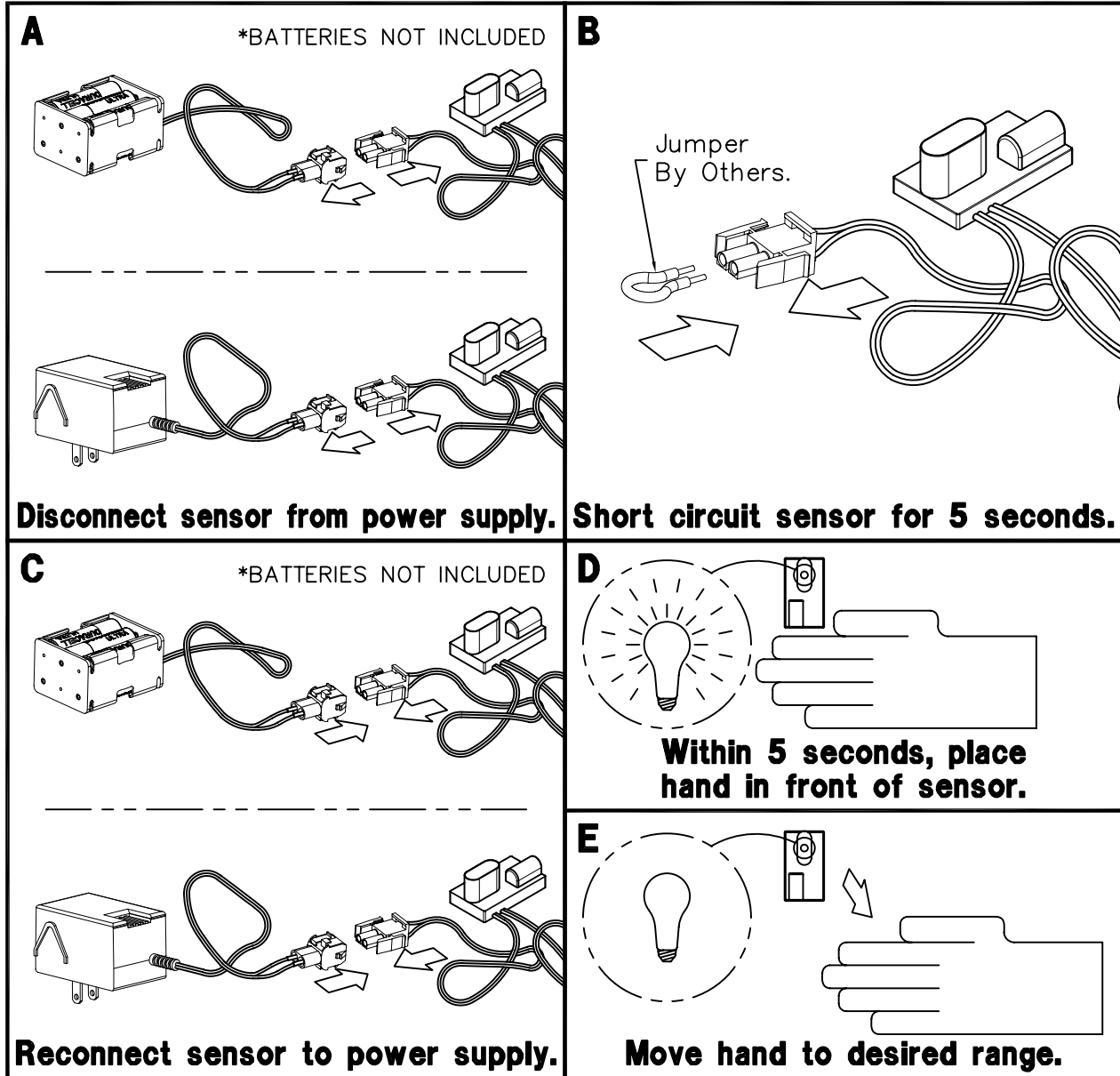

NOTE: THESE INSTRUCTIONS ONLY APPLY TO 9 VOLT SENSORS THAT DO NOT HAVE A RANGE ADJUSTMENT SCREW ON THE BACK. SEE DRAWING # 9927-222-001.

INSTRUCTIONS:

- A- Disconnect sensor from power supply.
- B- Create a short circuit between the positive and negative connections on the sensor for five seconds. **WARNING:** Do not create a short circuit on the power supply or while the sensor is connected to the power supply.
- C- Reconnect the sensor to the power supply.

- D- Within 5 seconds of making the connection, place hand 2 to 4 inches from the sensor.
- E- Once red light begins flashing quickly, move hand to preferred distance and wait for light to stop flashing.
- F- Check distance. If unsatisfactory, repeat steps A through E.

ACORN ENGINEERING COMPANY P.O. BOX 3527 INDUSTRY, CA. 91744 (626) 336-4561 FAX (626) 961-2200	TITLE 9 VOLT DC SENSOR RANGE ADJUSTMENT		
	MANUFACTURE DATE SEPTEMBER, 2001 TO PRESENT	DATE ISSUED 09/06/01	DRAWING NUMBER 9927-222-002
	DATE REVISED 09/30/11		

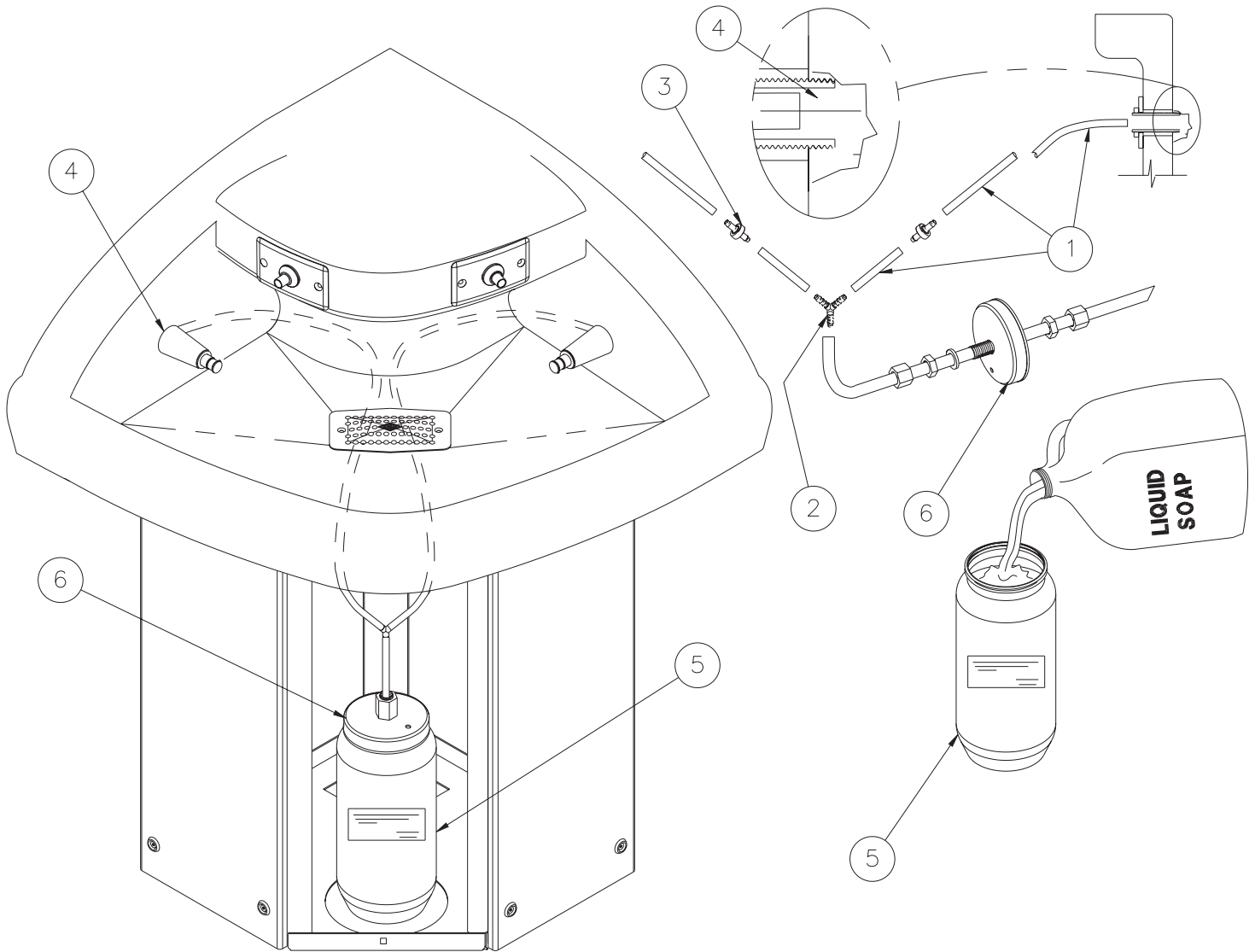

REFERENCE DRAWINGS	
-PDM SOAP DISPENSER	9965-260-002
-PDM SOAP TANK	9965-265-002

INSTALLATION INSTRUCTIONS:

A- ENSURE THAT 3/8" O.D. TUBING (1) IS SECURELY ATTACHED TO WYE (2) ADAPTER AND CHECK VALVES (3).

C- FILL SOAP TANK (5) WITH LIQUID SOAP BY OTHERS, REPLACE LID (6). SECURE PANEL ON PEDESTAL.

B- ASSEMBLE 3/8" O.D. TUBING (1) FROM SOAP TANK (5) TO REAR OF SOAP DISPENSER (4). TUBING ATTACHES TO BARBED FITTING WITHIN REAR OF SOAP DISPENSER.

ACORN ENGINEERING COMPANY P.O. BOX 3527 INDUSTRY, CA. 91744 (626) 336-4561 FAX (626) 961-2200	TITLE -PDM SOAP DISPENSER INSTALLATION INSTRUCTIONS	
	MANUFACTURE DATE OCTOBER 1990 TO PRESENT	DATE ISSUED 11/07/01 DATE REVISED 11/03/04



CORTERRA SOLID SURFACE

MAINTAINING CORTERRA:

CORTERRA SHOULD BE KEPT CLEAN AT ALL TIMES. IF MAINTAINED, CORTERRA SURFACES WILL RETAIN THEIR NEW, CLEAN APPEARANCE INDEFINITELY.

IN ORDER TO REMOVE ANY UNWANTED STAINS, WASH WITH SOAPY WATER THEN RINSE.

IN ORDER TO PREVENT WATER STAINS FROM OCCURRING, DRY SURFACE RIGHT AFTER RINSING. IF THE STAIN PERSISTS, USE A SCOTCH BRITE PAD AND AN CAN ALSO USE A SOLUTION CONSISTING OF HOUSEHOLD BLEACH AND WATER (1 PART WATER TO 1 PART BLEACH). RINSE AND WIPE SURFACE DRY.

REPAIRING CORTERRA:

TO REMOVE CUTS AND SCRATCHES USE 400 GRIT SANDPAPER, FOLLOWED BY AN ABRASIVE CLEANER AND SCOTCH BRITE PAD.

TO REPAIR CHIPPED CORTERRA:

(USING REPAIR KIT AVAILABLE FROM ACORN) DO THE FOLLOWING:

- 1- PUT ON GLOVES PRIOR TO HANDLING ANY OF THE MATERIALS IN THE KIT, AND ENSURE ADEQUATE VENTILATION.
- 2- ADD CONTENTS OF "B" (LIQUID RESIN) TO LARGER CONTAINER "A" (SOLID FILLER). MIX COMPLETELY USING WOODEN STICK.
- 3- ADD TUBE OF "C" (LIQUID CATALYST). MIX FOR TWO (2) MINUTES.
CAUTION: CATALYST GEL TIME AT 75° F IS 15 MINUTES.
- 4- APPLY MIXED MATERIAL TO DAMAGED AREA USING WOODEN STICK.
NOTE: APPLY ONLY AS MUCH PATCH AS REQUIRED.
- 5- LET CURE APPROXIMATELY 3-4 HOURS.
NOTE: FOR A "FAST CURE" OF APPROXIMATELY 10 MINUTES, USE A LAMP WITH A 100 WATT LIGHT BULB SHINING ON PATCHED AREA ABOUT 2-1/2" FROM PATCH.
- 6- USE COARSE GRAINED SANDPAPER TO SAND OFF EXTRA MATERIAL ONCE PATCH IS HARD.
- 7- USE MEDIUM GRAINED SANDPAPER FOR FINER FINISH.
- 8- USE FINE GRAINED SAND PAPER FOR "POLISHED" FINISH.
- 9- DISCARD EXTRA PATCH MATERIAL

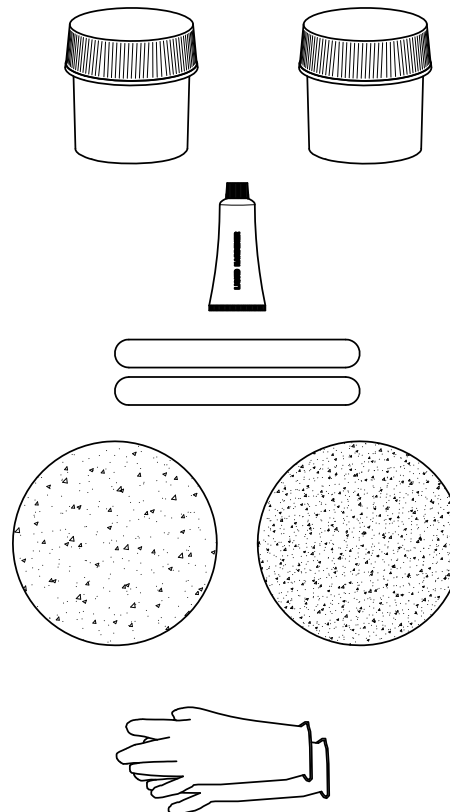

KIT NUMBERS	COLOR
6206-456-001	PEPPERCORN (OCC06)
6206-530-001	SMOKEY GRANITE (OCC01A)
6206-531-001	IVERSTONE (OCC02A)
6206-532-001	SAHARA (OCC03A)
6204-533-001	SUNSET STONE (OCC05A)
6206-535-001	IMPERIAL JADE (OCC07A)
6206-536-001	MIDNIGHT SAPPHIRE (OCC08A)
6206-537-001	OBSIDIAN (OCC09A)
6206-538-001	ANTIQUÉ LACE (OCC10A)

WARNING! REPAIR KIT MATERIALS ARE FLAMMABLE, KEEP AWAY FROM HEAT, SPARKS AND OPEN FLAME. AVOID WITH SKIN. WASH WITH SOAP AND WATER AFTER SKIN CONTACT. IN CASE OF EYE CONTACT, FLUSH WITH WATER FOR 15 MINUTES AND GET MEDICAL ATTENTION. HARMFUL IF SWALLOWED. KEEP OUT OF REACH OF CHILDREN.

ACORN ENGINEERING COMPANY P.O. BOX 3527 Industry, CA 91744 15125 Proctor Ave Industry, CA 91746 (626) 336-4561 FAX (626) 961-2200	TITLE CORTERRA MAINTENANCE & REPAIR SHEET		
	MANUFACTURE DATE DECEMBER 1997 TO PRESENT	DATE ISSUED 05/18/12 DATE REVISED	DRAWING NUMBER 9927-160-002



Programable Piezo Pushbutton Programming Instructions (Flow Time Adjustment)

The Button is factory set an 8 sec. timing cycle, if an 8 sec. cycle is adequate, then **no** programming adjustment is required.



NOTE: Read the entire document before trying to program the piezo pushbutton.

THE TIME SETTINGS PROGRAM USES 3 DIFFERENT TIMING MODES:

- **1 second timing mode:** Each push of the button adds 1 second to the total timing cycle.
- **5 second timing mode:** Each push of the button adds 5 seconds to the total timing cycle.
- **20 second timing mode:** Each push of the button adds 20 seconds to the total timing cycle.

To program the piezo pushbutton, you will need to be able to see the back of the piezo pushbutton.

Prevision must be made to access the back of the piezo pushbutton. There is an LED on the back of the piezo pushbutton under a layer of transparent epoxy, used as a programming indicator light.



NOTE: This programming procedure moves along rapidly, there is only about 2 or 3 seconds between programming operations.

In order to start the programming the piezo pushbutton, the button must be powered down. Disconnect the red power cable and wait 20 seconds, then reconnect the red power cable.

As soon as the cable is reconnected the LED will start flashing, it will flash 4 times, then stays on for 3 seconds. During the 3 second period, push the piezo button once, the LED will go out, now you are in the **1 sec timing mode** and each time the button is pushed the LED will flash, adding 1 sec to the total timing cycle.

To move on to the **5 sec timing mode**, pause and wait for the LED to flash 2 times, now you are in the 5 sec timing mode. Each time the button is pushed the LED will flash, adding 5 sec to the total timing cycle.

To move on to the **20 sec timing mode**, pause and wait for the LED to flash 3 times, now you are in the 20 sec timing mode and each time the button is pushed the LED will flash, adding 20 sec to the total timing cycle. After programing is complete, pause and wait for the LED to flash 4 times and then 5 times, which completes the programming.

- When a **timing mode is not required** then **do not** push the button and wait for the next timing mode.
- Each timing mode (1 sec, 5 sec or 20 sec timing mode) can be sequenced up to 100 times, that is the number of times, the button can be pushed, to increase the total timing cycle in each timing mode.



Please visit www.acorneng.com for most current specifications.

Programmable Piezo Pushbutton Programming Instructions (Flow Time Adjustment)

WORKSHEET

(FILL IN ALL BOXES, WHICH WILL SIMPLIFY THE PROGRAMMING PROCEDURE)

Fill in all the Boxes below
↓ ↓

Determine the number of seconds per timing cycle

1 Push = 1 Second
 x 1 = sec



- PROGRAMING STEPS:**
- Power down piezo button for 10 seconds.
 - Reconnect power.
 - LED flashes, then stay on.
 - While the LED is steady on, push button.
 - LED turns off.

- You are in the 1 sec timing mode, immediately push the button, 1 push equals 1 sec added to the total timing cycle.
- Pause and wait for the LED to flash 2 times.

ADD ↑ ↓

1 Push = 5 Seconds
 x 5 = sec



- You are in the 5 sec timing mode, immediately push the button, 1 push equals 5 sec added to the total timing cycle.
- Pause and wait for the LED to flash 3 times.

ADD ↑ ↓

1 Push = 20 Seconds
 x 20 = sec



- You are in the 20 sec timing mode, immediately push the button, 1 push equals 20 sec added to the total timing cycle.

EQUALS ↓

Total timing cycle equals
 seconds



INSTALLATION, OPERATIONS & MAINTENANCE MANUAL

Please visit www.acorneng.com
for most current specifications.

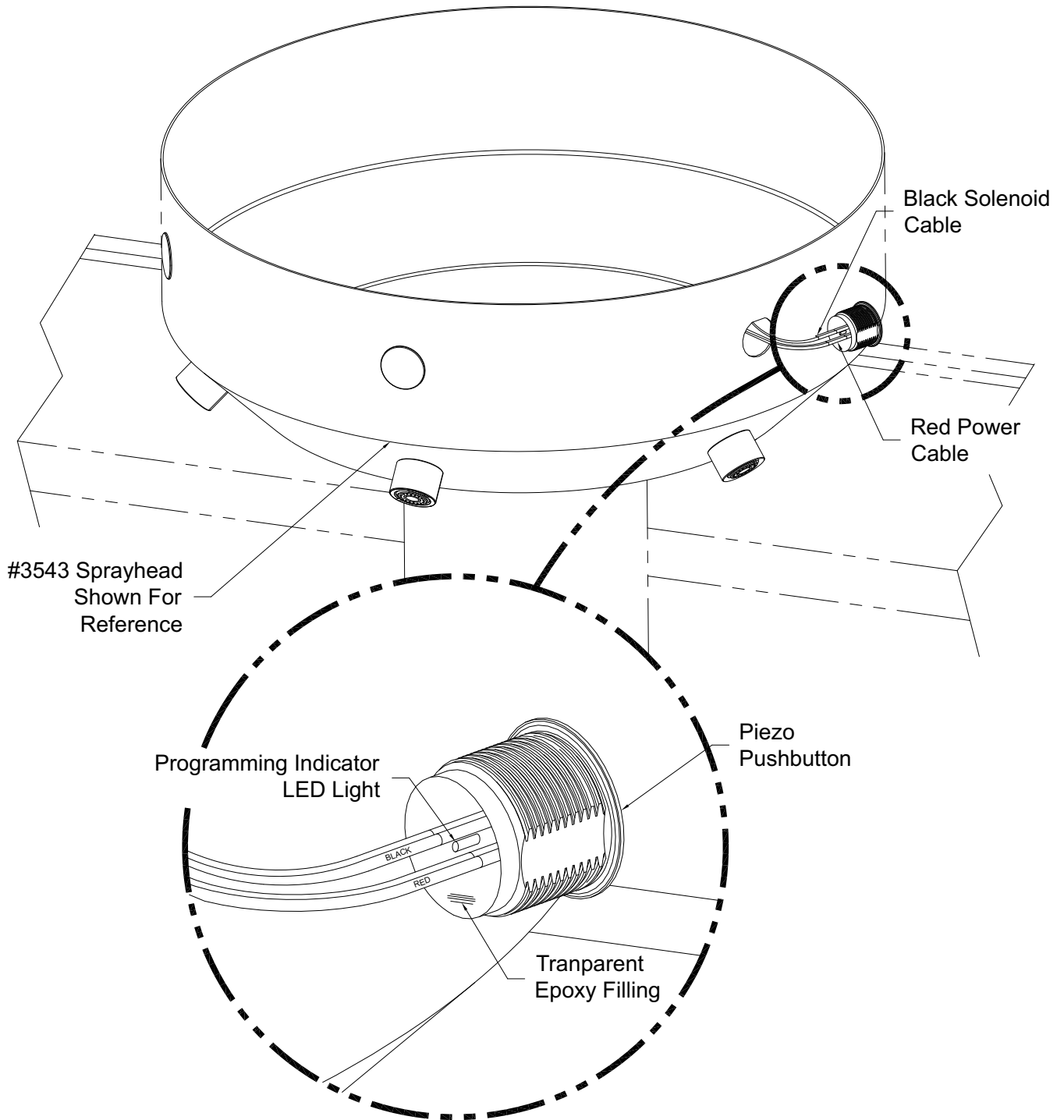

Part #: 9940-009-001

New: 10/01/13

ACORN ENGINEERING COMPANY

ACORN ENGINEERING FIELD SERVICE
TOLL FREE 800-743-8259 • LOCAL 626-855-4866 • FAX 626-855-4863