



Whitehall Manufacturing®
Manufacturer of Healthcare and Rehabilitation Products since 1946

WH2145 Series Ligature Resistant Cistern Tank Toilet



TABLE OF CONTENTS

Cover Page	1
Dimensional Data	2
Rough-Ins	3
Installation	4-6
Troubleshooting	7
Warranty	8

REQUIRED ITEMS FOR INSTALLATION - NOT SUPPLIED

- ✍ Toilet Ballcock Water Supply Line
- ✍ Closet Ring Gasket
- ✍ Closet Flange Hardware
- ✍ 1/2" x 13 UNC (4 Count) Closet Fixture Wall Anchors (with Appropriate Tools)
- ✍ Ø7/16" X 5/8" (2 Count) Tank Back Panel Wall Anchors and Anchoring Hardware (with Appropriate Tools)



! IMPORTANT

Important: Some options may slightly alter installation. To ensure proper installation review the manual thoroughly and verify rough-ins before beginning any work. File this manual with the owner or maintenance personnel upon completion of installation.

Industry standard wall backing, for wall hung fixtures, is required. Installer provided wall anchors and wall anchoring hardware must be appropriate for wall construction, and have a minimum pull-out rating of 1000 lbs. (453.6 kg).

DIMENSIONAL DRAWING

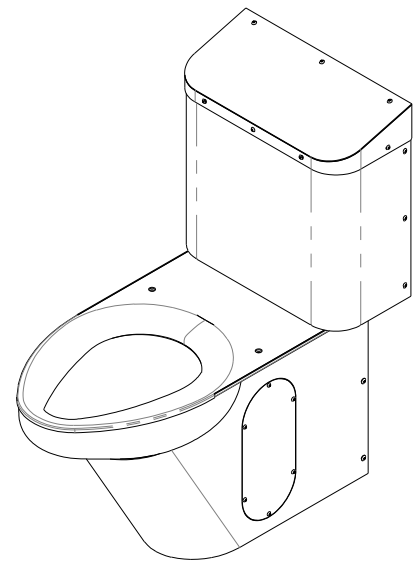
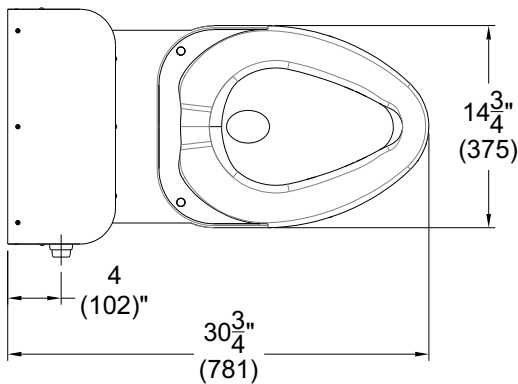

! IMPORTANT

Model WH2145-12 shown for reference only. Overall Dimensions may vary upon customer specified fixture.

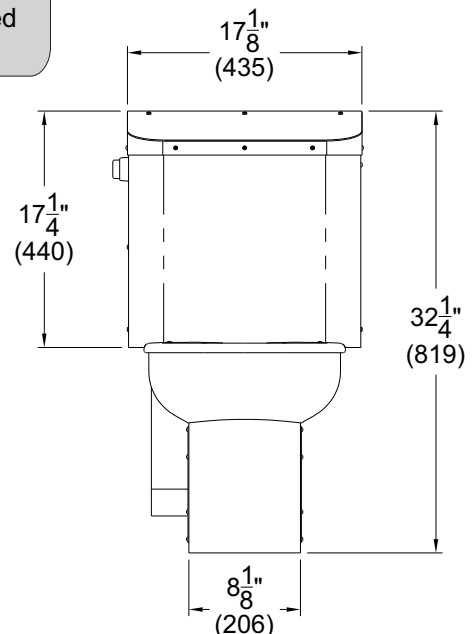
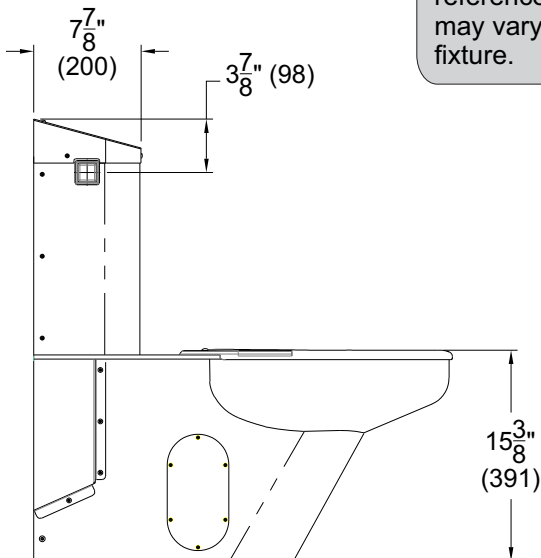



ROUGH-IN DRAWING:

WH2145 TOILET

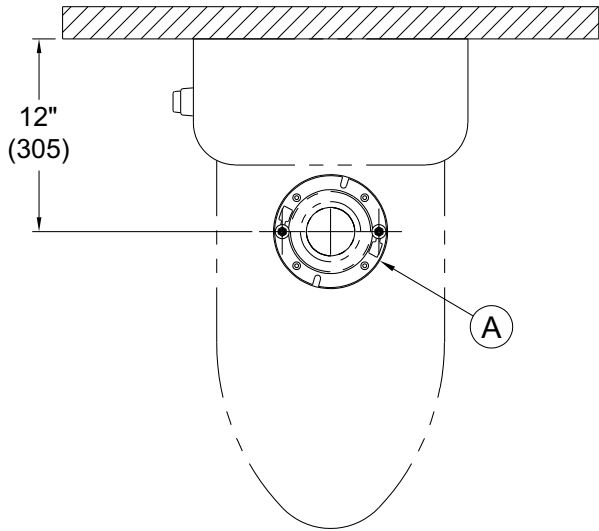

! IMPORTANT

Model WH2145-12 shown for reference only. Waste Location will Vary upon customer specified fixture.

- (A) ROUGH-IN FOR 7-1/2" CLOSET FLANGE WASTE OUTLET BY OTHERS
- (B) WALL ANCHORS AND MOUNTING HARDWARE BY OTHERS FOR CISTERN Ø7/16" x 5/8" LONG SLOT PUNCHING, 2 PLACES
- (C) WALL ANCHORS BY OTHERS FOR TOILET Ø5/8" x 1-1/2" LONG SLOT PUNCHING, 4 PLACES
- (D) SUPPLY AND ANGLE STOP FOR CLOSET 7/8" BALLCOCK SUPPLY INLET HOSE BY OTHERS

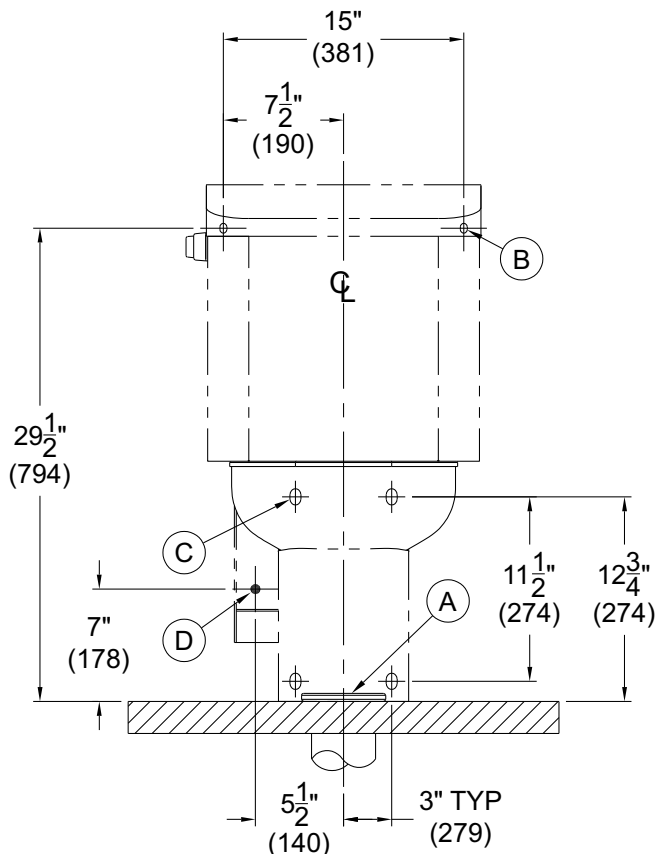



INSTALLATION:

WH2145 TOILET

1 Carefully remove all fixture components from packaging, preventing scratching or damage. Inspect fixture and all parts from damages and all parts that are bolted on.

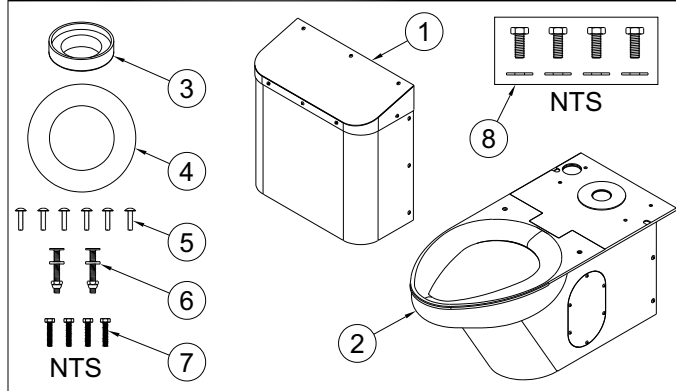

- ① Cistern Tank
- ② Water Closet (Toilet)
- ③ Red Rubber Gasket
- ④ Black Rubber Gasket
- ⑤ 1/4"-20 UNC
- ⑥ T-Bolt Assembly
- ⑦ 1/4"-20 X 1" Hex Head Cap Screw
- ⑧ 1/2"-13 UNC Toilet Mounting Hardware

2 Clean any construction debris out of Floor Flange (provided by others) and install the T-Bolts into slots of the Flange. Center Closet Gasket Ring (provided by others) on Floor Flange.

- ① T-Bolt (Qty. 2)
- ② Floor Flange (provided by others)
- ③ Closet Gasket Ring (provided by others)
- ④ Finished Floor

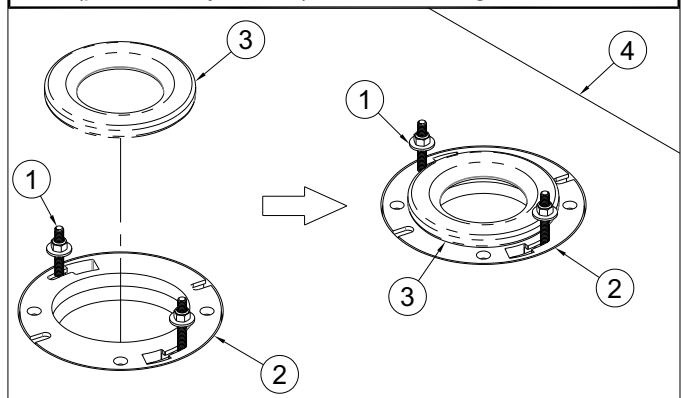

3 Remove Fixture Access Panels. Align fixture outlet over Closet Flange and against wall, setting fixture on the floor firmly in place onto Closet Flange and T-Bolts. Secure Closet Flange.

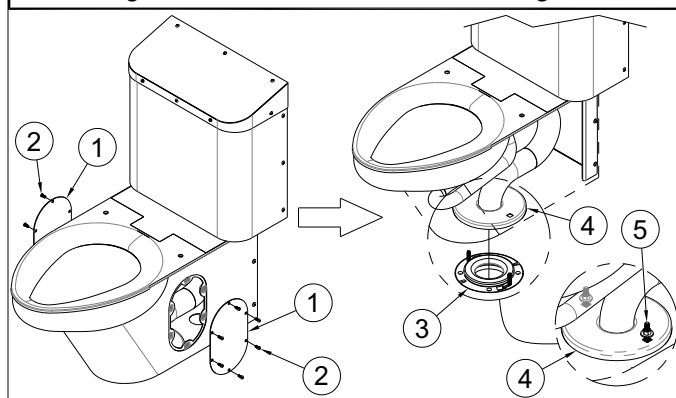

- ① Access Panel (Qty. 2)
- ② #10-32 Hex C/R Button Head Screw (Qty. 12)
- ③ Floor Flange
- ④ 7-1/2" Gasket Flange, Waste
- ⑤ T-Bolt (Qty. 2)



INSTALLATION:

WH2145 TOILET

4 Anchor fixture through Access openings. With Fixture secured to Closet Floor Flange, Anchor fixture to wall. Wall Anchors are by others.

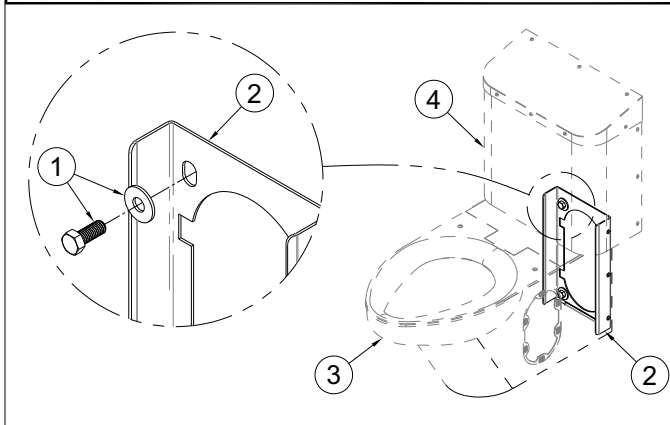

- ① 1/2"-13 UNC Toilet Mounting Hardware (Qty. 4)
- ② Water Closet (Toilet) Mounting Channel
- ③ Water Closet (Toilet)
- ④ Cistern Tank

5 Grab Red Rubber Gasket and install onto Cistern Tank by stretching Red Rubber Gasket over Cistern Tank Bottom Nut.

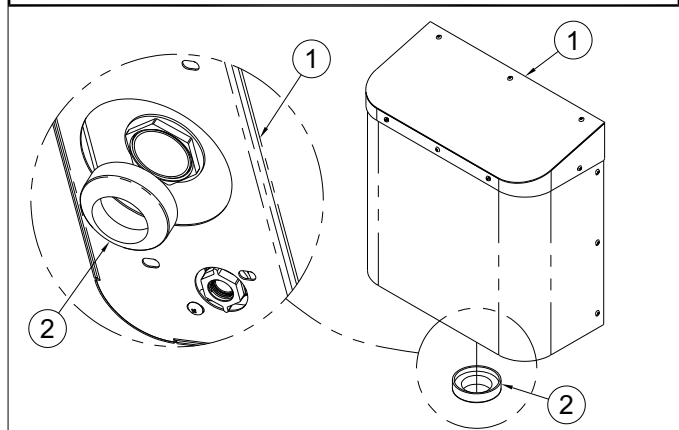

- ① Cistern Tank
- ② Red Rubber Gasket

6 With Red Gasket installed, position larger Black Gasket onto Toilet as shown and secure Tank Assembly to Toilet fixture using 1/4"-20 Hex Head Cap Screws.

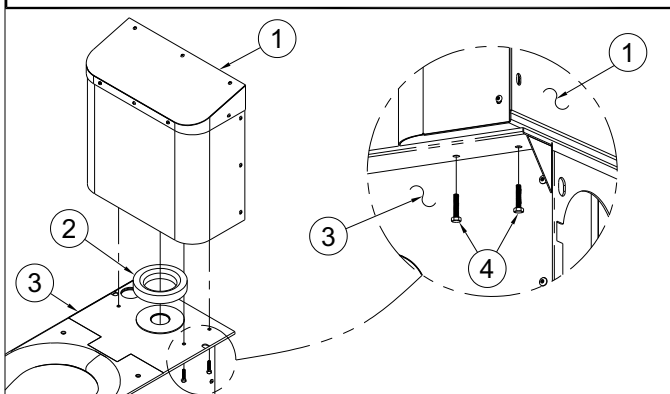

NOTE: Angle Stop Cover may be required to be removed to fasten left hand side Cap Screws.

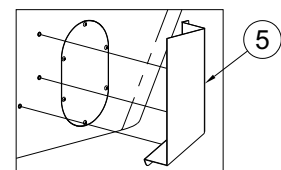

- ① Cistern Tank
- ② Black Rubber Gasket
- ③ Water Closet (Toilet)
- ④ 1/4"-20 X 1" Hex Head Cap Screw (Qty. 4)
- ⑤ Angle Top Cover



INSTALLATION:

WH2145 TOILET

7 With Fixture secured, remove Cistern Tank Top Access Cover. Anchor Cistern Tank to wall utilizing Ø7/16" X 5/8" slots. Anchoring and Anchoring Hardware provided by others.

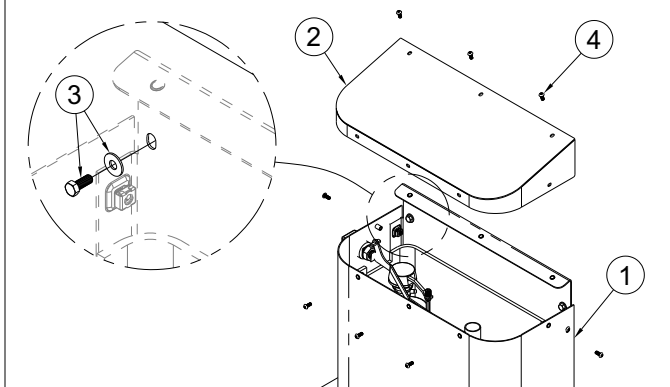

- ① Cistern Tank
- ② Cistern Tank Top Access Cover
- ③ Anchoring and Anchoring Hardware (Qty. 2)
- ④ #10-32 Hex C/R Button Head Screw (Qty. 8)

8 If Supply Cover was not removed in previous step, remove Supply Cover.

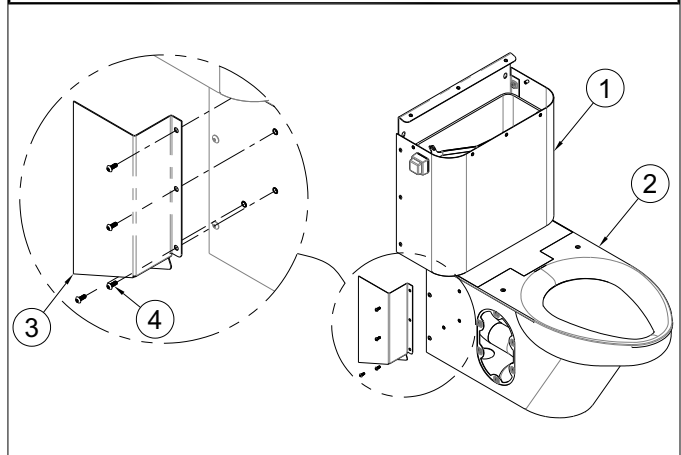

- ① Cistern Tank
- ② Water Closet (Toilet)
- ③ Supply Cover
- ④ #10-32 Hex C/R Button Head Screw (Qty. 4)

9 Flush Supply Line thoroughly before making up supply connections from Angle Stop and 7/8" Ballcock Inlet Hose to inlet connection on Tank. Re-install all Panels and Covers.

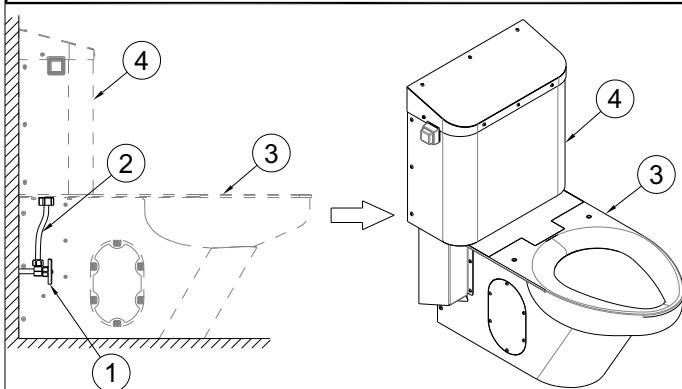

! IMPORTANT

Test fixture and check for any leaks, before re-installing all Panels and Covers.

- ① Angle Stop (provided by others)
- ② 7/8" Ballcock Inlet Hose (provided by others)
- ③ Water Closet (Toilet)
- ④ Cistern Tank



TROUBLESHOOTING:

WH2145 TOILET

1. FIXTURE DOES NOT FLUSH COMPLETELY:

- a. Refer to Fluidmaster Troubleshooting.
- b. Increase the water level.

2. FIXTURE DOUBLE FLUSHES:

- a. Refer to Fluidmaster Troubleshooting.
- b. Decrease the water level.

3. FIXTURE IS NOT FLUSHING PROPERLY:

- a. Refer to Fluidmaster Troubleshooting or contact Fluidmaster.
- b. Fully open Supply Valve.
- c. Verify refill tube is connected with the Water Control and inserted into the overflow tube without any kinks or damage.
- d. Adjust water level. Refer to Fluidmaster installation for Water Level information.
- e. Verify chain has only 1/4" of slack.
- f. Adjust Flush Valve Floater.
- g. Verify rim holes are completely clean.
- h. New Black and Red Rubber Gasket may be required.

4. FILL VALVE TURNS ON AND OFF:

- a. Refer to Fluidmaster Troubleshooting.

5. WATER LEVEL IN BOWL KEEPS DROPPING:

- a. With a container, add water into the bowl until proper height is reached. Wait a few minutes.
 - If Water Doesn't drop, fixture is okay. Our recommendation would be to mark water level and keep track for future reference.
 - If Water drops, Bowl might have internal damage. Toilet may need to be replaced.

6. WATER CONTINUES FLOWING AFTER FLUSH CYCLE:

- a. Refer to Fluidmaster Troubleshoot or contact Fluidmaster.
- b. Replace Flapper.
- c. Readjust Flush Valve chain length as needed.

7. WATER BETWEEN TANK AND BOWL DURING FLUSH:

- a. Refer to Fluidmaster Troubleshooting.
- b. Verify Black and Red Rubber Gaskets are installed correctly
- c. Remove Tank Cover and place level across the Tank. Locate the Hex Cap Head Screws located underneath Fixture. Adjust the Hex Cap Head Screws a quarter turn at a time one each side. With each adjustment, verify tank is secure.
- c. Replace Black and Red Rubber Gasket

8. WATER IS DRIPPING FROM SUPPLY TUBE:

- a. Verify Supply Tube Nut is tightened.
- b. Verify Supply Tube is not damaged or cracked. If damaged, replace Supply Tube.



Whitehall Manufacturing®
Manufacturer of Healthcare and Rehabilitation Products since 1946

Mailing Address:

P.O. Box 3527 • City of Industry, CA 91744-0527 U.S.A.

Physical Address:

15125 Proctor Avenue • City of Industry, CA 91746 U.S.A.

Phone 800-782-7706 • 626-968-6681

Fax 626-855-4862

Web: www.whitehallmfg.com

E-mail: info@whitehallmfg.com

MANUFACTURER'S WARRANTY

Go to www.whitehallmfg.com to fill out eWarranty Registration, keyword search: WARRANTY.

Whitehall Manufacturing Company warrants that its products are free from defects in material or workmanship under normal use and service for a period of one year from date of shipment. Whitehall's liability under this warranty shall be discharged solely by replacement or repair of defective material, provided Whitehall is notified in writing within one year from date of shipment, F.O.B. Industry, California.

This warranty does not cover installation or labor charges, and does not apply to materials which have been damaged by other causes such as mishandling or improper care or abnormal use. The repair or replacement of the defective materials shall constitute the sole remedy of the Buyer and the sole remedy of Whitehall under this warranty. Whitehall shall not be liable under any circumstances for incidental, consequential or direct charges caused by defects in the materials, or any delay in the repair or replacement thereof. This warranty is in lieu of all other warranties expressed or implied. Product maintenance instructions are issued with each fixture, and disregard or non-compliance with these instructions will constitute an abnormal use condition and void the warranty. If you have any questions or require technical assistance, please call 800-743-8219.

NOTICE TO KEEP ORIGINAL PACKAGING- Regarding warranty claims: customer must retain original packaging for one year upon receipt of product. If packaging is discarded, it is the customer's responsibility to provide adequate packaging. Any shipping claims that are a direct result of customer-provided packaging materials will be handled by the shipper.



WHITEHALL MANUFACTURING • P.O. BOX 3527 • City of Industry, CA 91744-0527 U.S.A.
Phone (800) 782-7706 • (626) 968-6681 • Fax (626) 855-4862 • Web: www.whitehallmfg.com