

TD – 80611 A HUR-520



MOSMATIC

Hurricane

Technical Data

Pressure	4000psi
Temperature	250°F
RPM	max. 2000 rpm
Housing	ø20.5"
Water connection	3/8"NPTF
Nozzle connection	2x 1/8"NPTF
Throughput medium	water (pH 3-12)

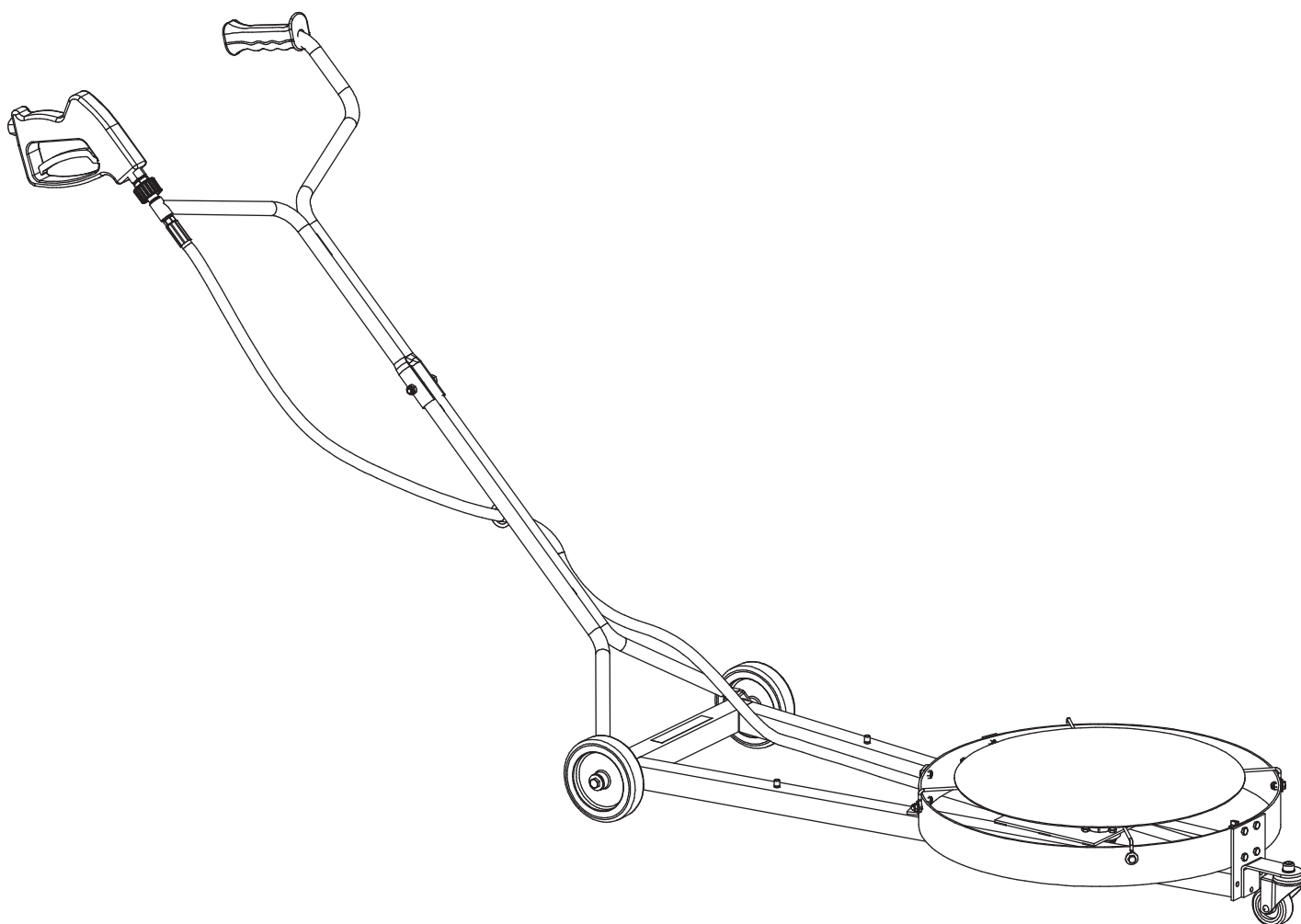

 **swiss quality**

MOSMATIC AG
CH-9126 Necker | Phone: +41 (0)71 375 64 64 | www.mosmatic.com

Datum / Date: 19.11.2015 | Änderungen vorbehalten | Subjects to change without notice

car wash technology | high pressure cleaning technology | rotary unions



Hurricane

Indication (original language German):

- Read all instructions, check overall conditions and safety requirements before initial operation of the product.
- Our product should only be installed by experienced users of high pressure equipment.
- Safety regulations and guidelines (Accident Prevention Rules) from the manufacturer of your high pressure cleaner are applicable.
- Nozzle installation according to Nozzle manufacturer.
- Do not run the product if the rotor-arm is out of balance or bent, damage to the swivel will result.
- No modifications to the product are permitted.

Caution:

- Always use protection gear when using products connected to high pressure.
- Before any maintenance or nozzle-change, turn off the high pressure water supply, e.g.: turn off and secure the power switch.
- After turning off the system, allow all selfpropelled equipment to come to a complete stop before handling. Risk of injury due the rotor-arm.
- Do not lift up the product while operating.

Warning:

- Never direct any high pressure water-jet at humans, animals or electric installations.
- Do not touch the rotor-arm during operation. Risk of injury.

	Declaration of Conformity Pressure Equipment Directive 97/23/EC Annex III.
Manufacturer:	Mosmatic AG Oberhelfenschwilerstrasse 6 CH - 9126 Necker Switzerland Phone: +41 (0) 71 375 64 64 Internet: www.mosmatic.com
We hereby declare that the product listed below based on the conception, design and construction in the design as we launch the product, conclusively at the time of the declaration applicable alterations, conforms to the safety requirements of the Pressure Equipment Directive.	
Product Description:	High Pressure Accessories
Type:	FL / DR / RDW / SPI / TYR / TYW
Product Characteristics:	Pressure Equipment Directive 97/23/EC Article 3 / Number 1.3 / Letter a) / Second dash Article 3 / Number 1.3 / Letter b) / Second dash Fluid Group 2
Applied Conformity Assessment Procedure:	Directive 97/23/EC Module H (Full Quality Assurance)
EC Standard Guidelines:	Machinery Directive 2006/42/EG Pressure Equipment Directive 97/23/EC
Applied Harmonized Standards:	ISO 12100:2011 - Safety of Machinery ISO 9001:2008 - Quality Management System
Authorised Person:	Patrick Rieben
By any modification from the product, alterations on the product or the fitting of non-approved spares is the validity of the declaration of conformity with immediately effective terminated.	
Necker, 2015	Signature:

Hurricane

Assembly Instructions (original language German)

1. Dismount both wheels (4).
2. Install the lower fork (14) with the bolts (15) through the wheels (4) to the rack (16).
3. Slide the upper fork (17) over the lower fork (14). Secure the two forks with the bolt (18) and the safety nut (19).
Note: The handle (20) and the ring (21) must point in the same direction.
4. Connect the HP-gun (8) with the preinstalled adapter (7) to the quick-connect (6).

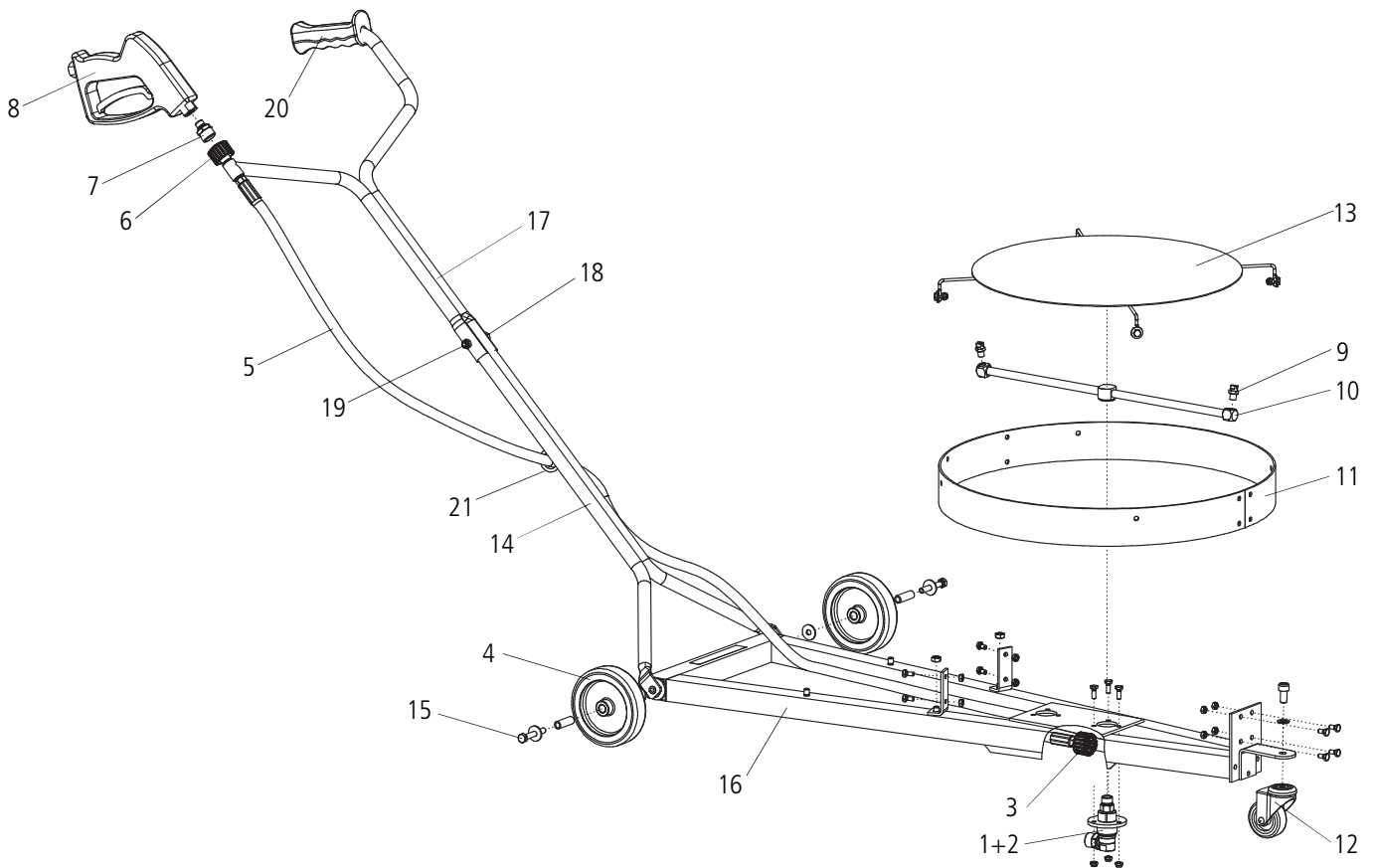

Spare parts list

Pos.	Art. Nr.	Description
1	58.553	Swivel-90° (DYF)
2	36.905	Carbide seal-kit
3	50.155	Quick-Connect (M22x1.5-F / G1/4" F)
4	900.933	Rubber wheel (ø5")
5	903.325	HP-hose (G1/4" kM / G1/4" kM)
6	50.903	Quick-Connect (M22x1.5-F / G1/4" M)
7	51.275	Adapter (M22x1.5-M / G1/4" M)
8	29.081	HP-gun (4500psi)
9	1503	HP-nozzle (1503)
10	82.891	Rotor arm (ø18.5")
11	903.318	Protection ring (ø20.5")
12	900.932	Stainless steel caster (ø2.4")
13	80.621	Protective plate (ø20.5")