

REV	DESCRIPTION	ECN #	CHG BY	DATE	APP'D
A	CONVERTED TO 3D, FINISH WAS BLACK	21138	NAS	02/05/21	JSR

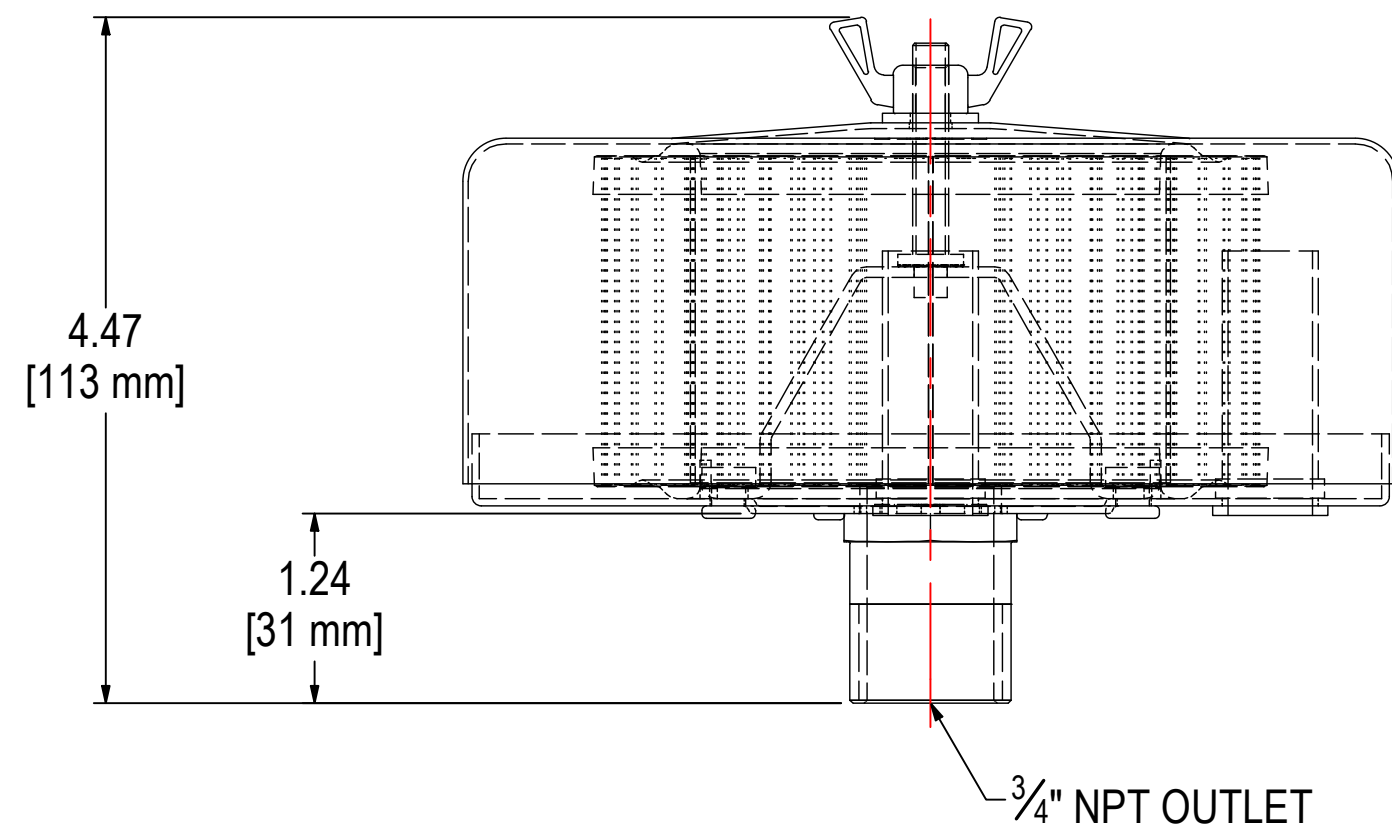
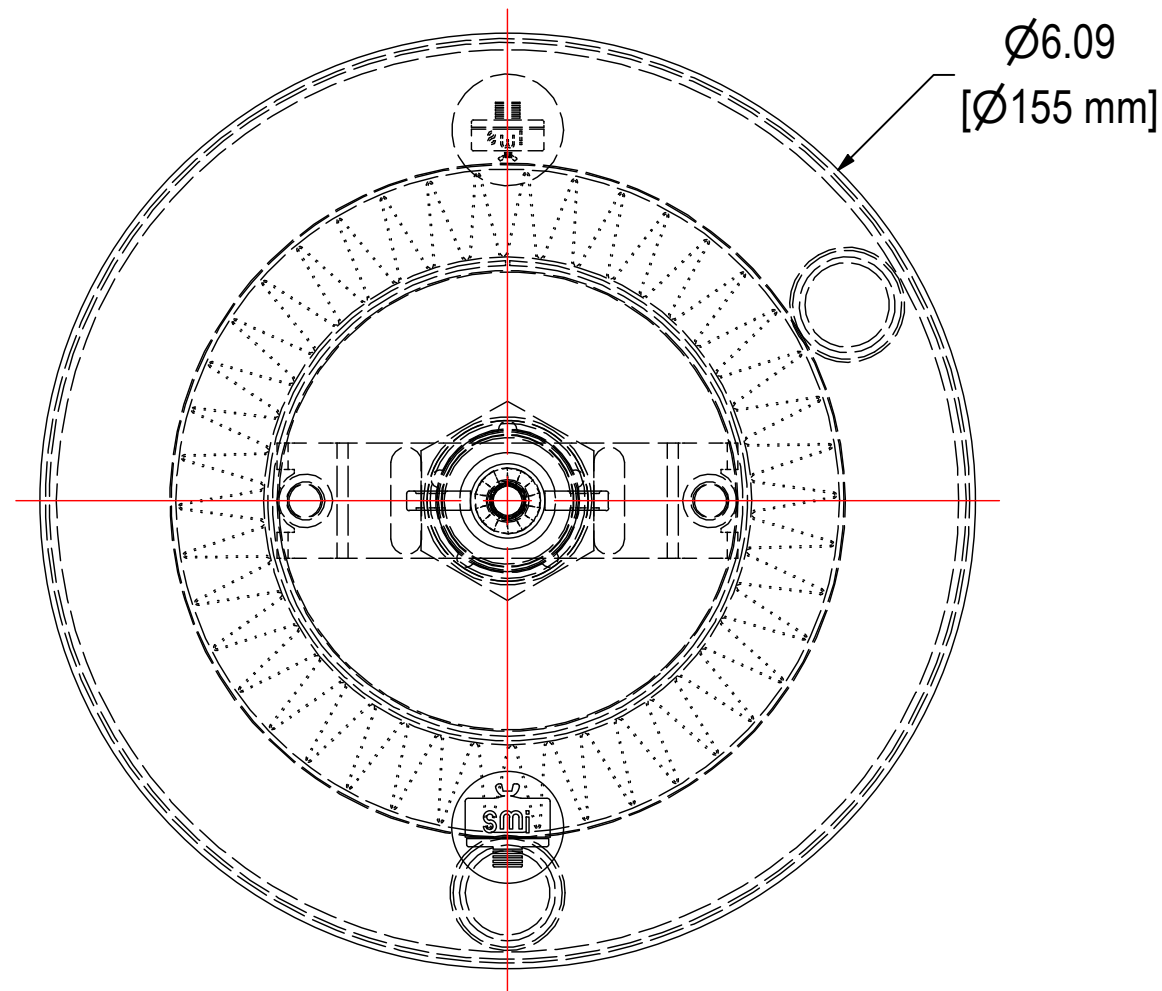

ELEMENT SPECS		
PART NUMBER	15	
MATERIAL	POLYESTER	
FLOW RATE	35 CFM	60 m <sup>3</sup> /hr
SURFACE AREA	0.5 ft <sup>2</sup>	0.0 m <sup>2</sup>
I.D.	3.00"	76mm
O.D.	4.37"	111mm
HEIGHT	2.32"	59mm

MODEL #: FS-15-075	MATERIAL: CARBON STEEL	FINISH: GRAY POWDER <span style="border: 1px solid black; padding: 0 2px;">A</span>	SHEET: 1 OF 1
MODEL NUMBER: FS-15-075		DESCRIPTION: FS-15-075, GRAY	
PROJECT: SD20910	DRAWN BY: CRW DATE: 1/29/2003	APPROVED BY: DATE:	REV: A

THE INFORMATION CONTAINED HEREIN IS CONFIDENTIAL AND THE PROPERTY OF SOLBERG MANUFACTURING INC. AND IT IS FURNISHED TO YOU WITH THE EXPRESS UNDERSTANDING THAT IT WILL NOT BE REPRODUCED, COPIED IN ANY MANNER, LOANED OR OTHERWISE TRANSFERRED TO OTHERS ENTIRELY OR IN PART, NOR USED FOR ANY PURPOSE OTHER THAN FOR WHICH IT WAS FURNISHED. IT WILL BE RETURNED UPON REQUEST TO SOLBERG MANUFACTURING INC. THE ABOVE RESTRICTION IS IN ADDITION TO, AND DOES NOT IN ANY WAY ALTER, ANY OTHER RESTRICTIONS WHICH MAY APPLY TO THE INFORMATION CONTAINED HEREIN.

**TOLERANCES**  
 DIMENSIONS ARE FOR REFERENCE ONLY. ALL DIMENSIONS ARE SUBJECT TO CHANGE UPON PRODUCTION.  
 UNLESS OTHERWISE SPECIFIED:  
 -DIMENSIONS ARE IN INCHES  
 -REF: APPROXIMATE DIMENSIONS, NO TOLERANCES APPLY  
 -FINISH: BREAK EDGES TO .005-.020 RADIUS/CHAMFER

**SOLBERG**<sup>®</sup>  
 Filtration • Separation • Silencing  
 630.773.1363 • www.solbergmfg.com