

Please read and save these instructions. Read carefully before attempting to assemble, install, operate or maintain the product described. Protect yourself and others by observing all safety information. Failure to comply with instructions could result in personal injury and/or property damage! Retain instructions for future reference.

# Dayton® Speed Reducers

## Description

Dayton Speed Reducers are in-line drive type units suitable for general purpose applications involving shop equipment, conveyors, etc. Units are manufactured with heavy duty hardened steel gears, deep groove ball bearings, double lip type shaft seals and a two piece die cast aluminum housing. First stage gear is helical; all others are spur.

**NOTE:** The speed reducer is designed for direct drive with NEMA 56C face, 1800 RPM (maximum) motor, purchased separately. Hardware for attaching the motor is included. Refer to specifications for input-horsepower and output torque capacities.

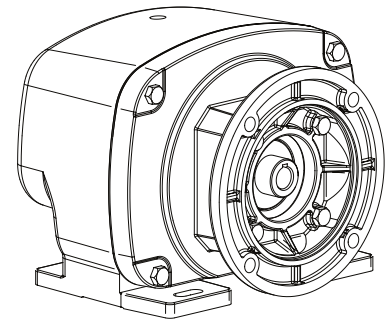

Figure 1

## Dimensions

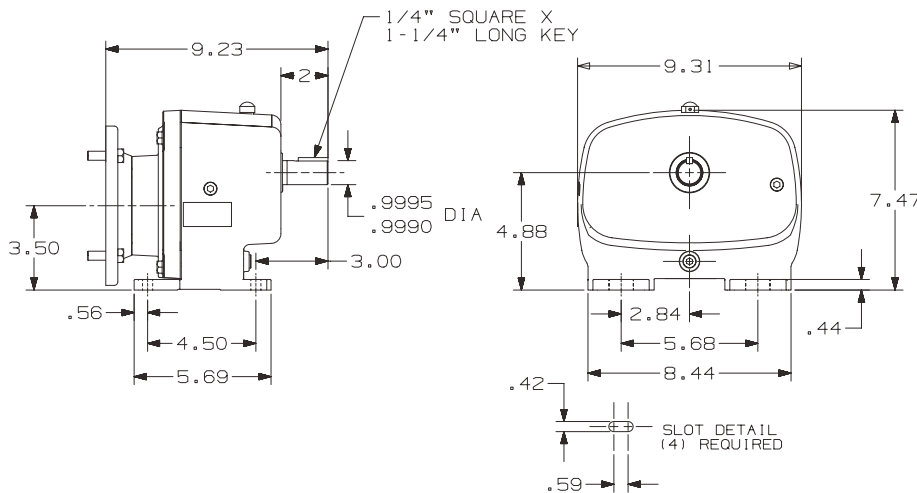

Figure 2

## Load Factor Chart

Type of Load	Load Factor
8 to 10 Hour Day Service	
With Moderate Shock Loads	0.85
24 Hour Day Service	
With No Shock Load Involved	0.93
24 Hour Day Service	
With Moderate Shock Loads	0.81

## Determine Output Torque Capacity

**NOTE:** To determine output torque capacity for operating conditions other than a normal 8 hour day and shock free operation, multiply the rated output torque by the applicable load factor listed. Shock loads should be avoided.

## Torque Capacity Chart

Model	Nominal Output RPM	Nominal Ratio	1/4 HP Torque In-Lbs	1/3 HP Torque In-Lbs	1/2 HP Torque In-Lbs	3/4 HP Torque In-Lbs	1 HP Torque In-Lbs
4Z720F	20	87:1	748	998	-	-	-
4Z614F	30	57.5:1	499	665	998	-	-
4Z615F	45	38.5:1	333	443	665	-	-
4Z616F	55	31:1	272	363	544	816	-
4Z617F	99	17.5:1	151	201	302	454	-
4Z719F	140	12.5:1	107	143	214	320	427

# Dayton® Speed Reducers

**▲ CAUTION** **Maximum momentary or starting torque is not to exceed 375% of rated output torque at 1725 RPM for applications involving four or more starts per hour.**  
**Unpacking**

When unpacking the unit, inspect carefully for any damage that may have occurred during transit. Check for loose parts, missing parts or damaged parts.

The carton should contain:

1. Speed reducer unit.
2. Hardware package consisting of:
  - (1) steel key (input) 3/16 x 3/16 x 1 3/8
  - (1) steel key (output) 1/4 x 1/4 x 1 1/4"
  - (4) hex head capscrews 3/8-16 x 1"
  - (1) vent plug
3. (1) Tube anti-seize compound.

## General Safety Information

1. Follow all local and safety codes, as well as the United States National Electrical Code (NEC) and the United States Occupational Safety and Health Act (OSHA).
2. Motor (not included with this unit) must be securely and adequately grounded. This can be accomplished by wiring with a grounded, metalclad raceway system, by using a separate ground wire connected to the bare metal of the motor frame, or by other suitable means. Refer to United States NEC Article 250 (Grounding) for additional information.
3. Always disconnect power source before working on or near a motor or its connected load. If the power disconnect point is out of sight, lock it in the open position and tag it to prevent unexpected application of power.
4. All moving parts should be guarded.

5. Be careful when touching the exterior of an operating motor; it may be hot enough to be painful or cause injury. Modern-design motors normally run hot at full-rated load.
6. Protect the power cable from coming in contact with sharp objects.
7. Do not kink the power cable and never allow the cable to come in contact with oil, grease, hot surfaces or chemicals..
8. Make certain that the power source conforms to the requirements of your equipment.
9. Before energizing the motor which drives the speed reducer, be sure that the reducer output shaft key is either fully captive, or is removed.
10. When cleaning electrical or electronic equipment, always use an approved cleaning agent such as dry cleaning solvent.

## Installation

**▲ WARNING** **When an installation involves a holding or overhauling application (such as a hoist or conveyer), a separate magnetic brake or other locking device should be used. Do not depend on gear friction to hold the load.**

1. Locate the speed reducer in a clean and dry area with access to adequate motor cooling air supply. If installation is outdoors, make certain that the reducer is protected from the weather.
2. Mount unit to a rigid flat surface, preferably metallic, using 3/8" bolts. If surface is not flat then shimming will be required under those feet which do not lie flat against the mounting surface.

**NOTE:** The speed reducer is intended

for horizontal floor, wall, or ceiling mounting only (the output shaft must be horizontal).

3. For shipment, 4 pipe plugs (Ref. Figure 5 No. 31) are installed in the unit, and a vent plug (Ref. Figure 5 No. 32) is packed separately. After mounting unit in position as instructed in Step 2, remove pipe plug located in highest position and install vent plug in its place. Check for correct oil level which is just below the mid level pipe plug (See Figure 3) The unit was filled at the factory to the floor mounted oil level.

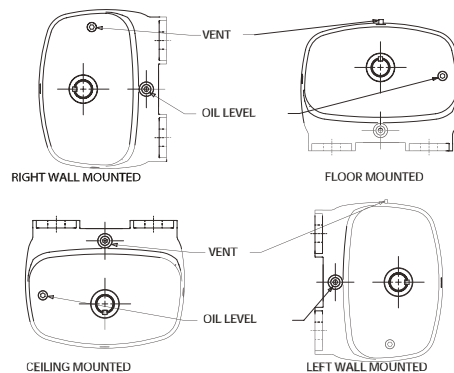

**Figure 3 - Correct Oil Levels**

4. Attach motor to speed reducer (See Figure 4).

**▲ CAUTION** **Do not exceed motor horsepower and torque ratings indicated on nameplate in Specifications.**

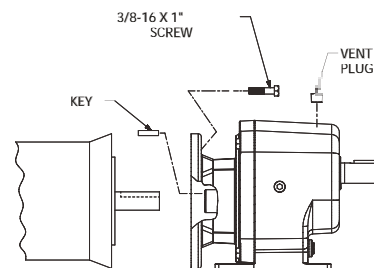

**Figure 4 - Attaching the Motor**

# Models 4Z614F thru 4Z617F, 4Z719F and 4Z720F

## Installation (Continued)

- a. Speed reducer is to be used with any NEMA Frame 56C face mounted, 1725 RPM electric motor without feet. Make sure motor shaft is clean and free of dirt. Wipe shaft with grease or light oil.

## Operation

**▲ CAUTION** Do not operate the reducer without making sure it contains the correct amount of oil. Doing so can damage the reducer. See Step 3 in installation section for correct oil level.

1. Run the motor which drives the reducer and check the direction of reducer output rotation. Consult motor nameplate for instructions to reverse the direction of motor rotation.
2. Attaching the Load.

**▲ WARNING** Make certain that the power supply is disconnected before attempting to attach the load.

- a. Direct Couple Installations: Carefully check shaft and coupling alignment between speed reducer and loading mechanism. Shim as required. Do not depend on a flexible coupling to compensate for misalignment.
- b. Chain/Sprocket and Belt/Pulley Installations: Locate the center line of the sprocket or pulley as close to the oil seal as practical to minimize overhung load and increase bearing life. Overhung load should not exceed limits shown in the following table.

Model	Output Shaft Overhung Load Limits*
4Z614F	885 lbs.*
4Z615F	863
4Z616F	712
4Z617F	773
4Z719F	709
4Z720F	1192

(\*): Based on load at 1 inch from oil seal

## Detailed Overhung Load Calculations

Sideward (radial) force on an output shaft is called overhung load. Driving a load through a sprocket, pulley, or gear which is mounted on the output shaft causes overhung load on the shaft. Too much overhung load can break the shaft or cause the bearings to fail prematurely. Locate the center line of the sprocket, pulley, or gear as close to the oil seal as practical to minimize overhung load and increase bearing life.

Calculate the amount of overhung load in your installation as follows:

$$\text{Overhung Load (LBS.)} = \frac{(2) \times (T) \times (D) \times (L)}{(P)}$$

The terms of the above formula are defined as follows:

- (T) = Full load torque of gearbox, in in-lbs, from specifications and performance
- (D) = Drive factor from following chart, accounting for type of drive
- (P) = Pitch diameter, in inches, of drive being mounted on gearbox output shaft
- (L) = Leverage factor from following chart, accounting for position of drive along length of gearbox output shaft

## Drive Factors

Sprocket . . . . .	1.00
Pulley. . . . .	1.50
Gear. . . . .	1.25
Flat belt pulley . . . . .	2.50

## Leverage Factors

Coupling location	Factor
End of shaft extension. . . . .	1.20
Center of shaft extension . . . . .	1.00
Next to shaft extension shoulder . . . . .	0.80

After calculating the amount of overhung load expected in your installation, compare it to the overhung load rating (limit) listed for your gearbox in Specifications and Performance. If the expected amount of overhung load is higher than the specified limit you must change a component or the location of a component in your installation to bring the overhung load within the limit. To increase the operating life of the gearbox bearings, design your installation to reduce overhung load as much as possible.

3. High Momentum Loads: Some applications involve a load which would tend to coast after turning off the motor. If coasting is undesirable, a braking mechanism should be provided to the speed reducer output or the mechanism being driven by the speed reducer.

**▲ CAUTION** Do not brake the motor or the speed reducer input shaft for the purpose of stopping a high momentum load. Doing so could result in failure of the speed reducer.

# Dayton® Speed Reducers

## Maintenance

**▲WARNING** Make certain that the power supply is disconnected before attempting to service or remove any components! If the power disconnect point is out-of-sight, lock it in the open position and tag it to prevent unexpected application of power.

## Cleaning

Properly selected and installed electric motors are capable of operating for long periods with minimal maintenance. Periodically clean dirt accumulations from open-type motors, especially in and around vent openings, preferably by vacuuming (avoids embedding dirt in windings). At the same time, check that the electrical connections are tight.

## Lubrication

The Dayton speed reducer was filled with oil at the factory to operate within +50° to +125° ambient temperature. After 2000 hours of operation, drain and refill with AGMA #4 gear oil. For low temperature use, use Mobilgear 629 (non-synthetic) 0° to 60° F, or Mobil Synthetic SHC629 -30° to 200° F. Never mix nonsynthetic with synthetic oil.

## Oil Seal Replacement

**▲CAUTION** A new seal will leak if the seal lips and/or the seal rubbing surface on the shaft has been altered or roughed up. Protect the seal lips at all times. Clean the shaft, but do not use any abrasives on the part of the shaft rubbed by the seal.

To prevent seal damage and gear misalignment when replacing the oil seal, proceed as follows:

1. Disassembly
  - a. Remove sprockets, pulleys, etc. that are mounted on the shaft where the seal is to be replaced.

- b. Use punch to pierce two or more holes in steel casing of seal. (Casing may be rubber coated).

**▲CAUTION** Do not drill holes in seal casing because metal chips may get inside reducer, damaging it.

- c. Insert sheet metal screws leaving the heads sufficiently exposed so they can be pried or grasped with pliers.
- d. Work seal loose. Be careful to keep all metal or dirt particles from entering reducer.
- e. Remove old sealing compound from seal seat, if present
- f. Remove burrs and sharp edges from shaft.
- g. Clean shaft with solvent-soaked rag.

**▲CAUTION** Do not use abrasive material on shaft seal contacting surfaces.

## 2. Reassembly

**▲CAUTION** Protect seal lips when handling seal. Leakage will result if lips are damaged. If a seal with rubber coating on the outside diameter (O.D.) is used, no sealant is necessary. If no rubber coating is on seal O.D., coat bore with Permatex No. 3 or equivalent sealing compound. Protect seal lips from shaft keyway edges by wrapping shaft with thin, strong paper coated with oil. Coat seal lips with bearing grease and carefully work seal into position.

- a. Place seal, open side (with garter spring) facing reducer, on shaft or in recess of housing.
- b. Place the face of a pipe or tube (face must be flat, smooth and square to the length of the pipe or tube) against the seal and drive

or press seal until sealed in the same position as the seal that was removed.

**▲CAUTION** Do not strike seal directly.

## Models 4Z614F thru 4Z617F, 4Z719F and 4Z720F

### Troubleshooting Chart

Symptom	Possible Cause(s)	Corrective Action
Unit fails to operate	<ol style="list-style-type: none"> <li>1. Blown fuse or open circuit breaker</li> <li>2. No power</li> <li>3. Defective motor</li> <li>4. Excessive load</li> </ol>	<ol style="list-style-type: none"> <li>1. Replace fuse or reset circuit breaker</li> <li>2. Contact power company</li> <li>3. Repair or replace</li> <li>4. Reduce load</li> </ol>
Motor runs but no output	<ol style="list-style-type: none"> <li>1. No input key</li> <li>2. Failed gear(s)</li> </ol>	<ol style="list-style-type: none"> <li>1. Install key (See Installation)</li> <li>2. Check and replace if necessary</li> </ol>
Intermittent rotation of output shaft	<ol style="list-style-type: none"> <li>1. Poor electrical connection</li> <li>2. Damaged gear assembly possibly caused by shock load</li> </ol>	<ol style="list-style-type: none"> <li>1. Check connection</li> <li>2. Replace gear and if possible, avoid shock load</li> </ol>
Excessive noise	<ol style="list-style-type: none"> <li>1. Bearing worn</li> <li>2. Belt too tight</li> <li>3. Overhung load - exceeds rating and causes bearing wear</li> <li>4. Insufficient lubrication</li> </ol>	<ol style="list-style-type: none"> <li>1. Replace</li> <li>2. Adjust tension</li> <li>3. Correct load and/or replace bearing</li> <li>4. Check oil level</li> </ol>
Unit leaks oil	<ol style="list-style-type: none"> <li>1. Vent plug not installed</li> <li>2. Gasket broken or seated improperly</li> <li>3. Damaged or worn seal</li> <li>4. Too much oil</li> <li>5. Housing bolts (Ref. No. 26) loose</li> <li>6. Seal cage bolts (Ref. No. 22) loose</li> </ol>	<ol style="list-style-type: none"> <li>1. Install vent plug</li> <li>2. Reseat gasket or replace</li> <li>3. Replace</li> <li>4. Check oil level</li> <li>5. Tighten to 200 in-lb torque</li> <li>6. Tighten to 200 in-lb torque</li> </ol>

# For Repair Parts, call 1-800-323-0620

24 hours a day - 365 days a year

Please provide the following information:

- Model number
- Serial number (if any)
- Part description and number as shown in parts list

Address parts correspondence to:

Grainger Parts  
 P. O. Box 3074  
 1657 Shermer Road  
 Northbrook, IL 60065-3074 U.S.A.

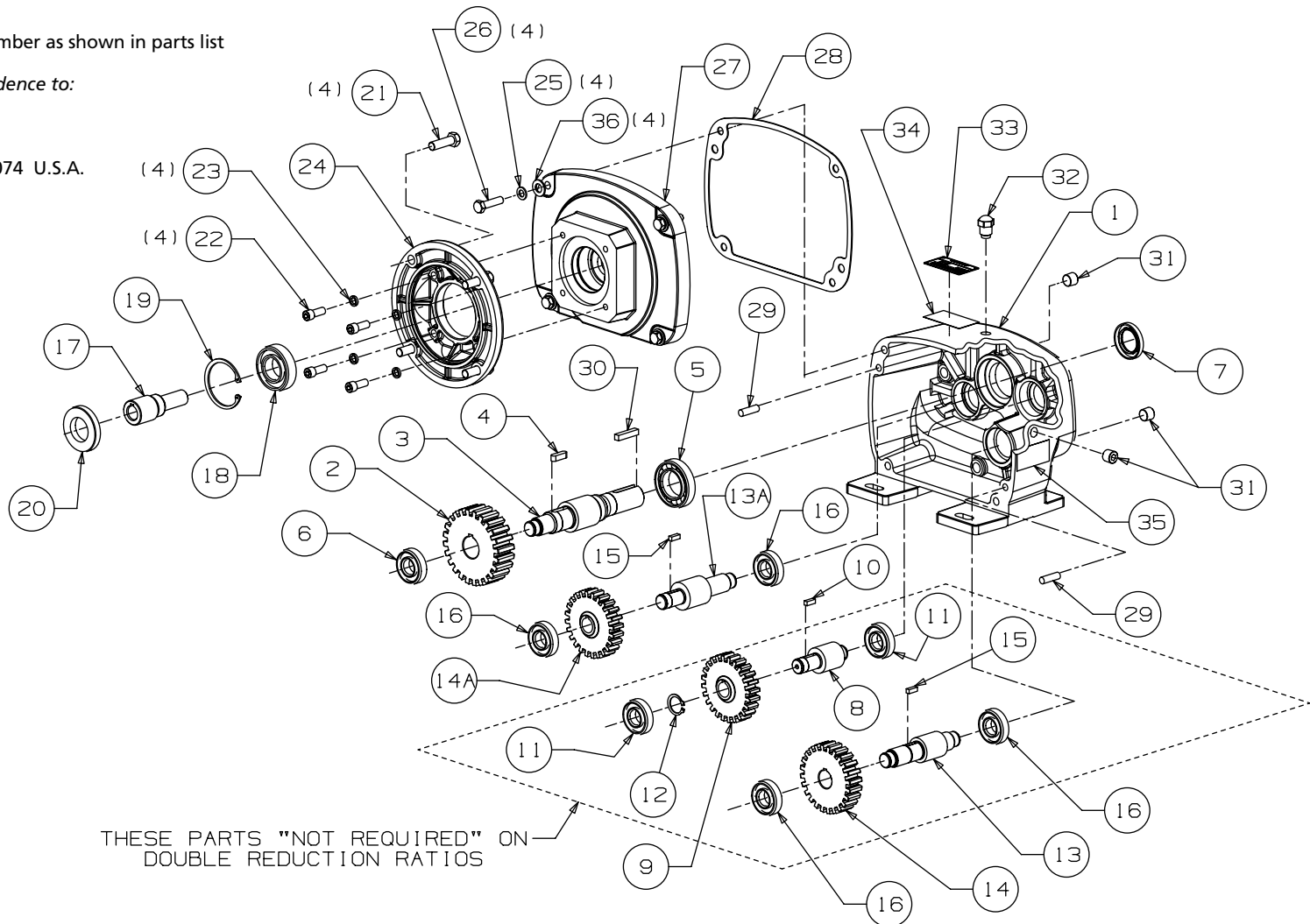

Figure 5 - Repair Parts Illustration

# Repair Parts List

Ref. No.	Description	Model 4Z614F		Model 4Z615F		Model 4Z616F		Model 4Z617F		Model 4Z719F		Model 4Z720F	
		Part No.	Qty	Part No.	Qty	Part No.	Qty	Part No.	Qty	Part No.	Qty	Part No.	Qty
1	Gear housing	XG4Z-1	1	XG4Z-1	1	XG4Z-1	1	XG4Z-1	1	XG4Z-1	1	XG4Z-1	1
2	† Output gear	54T (84451)	1	55T (84450)	1	52T (84453)	1	54T (84455)	1	53T (84452)	1	55T (84450)	1
3	Output shaft	XG4Z-3A	1	XG4Z-3A	1	XG4Z-3A	1	XG4Z-3AA	1	XG4Z-3AA	1	XG4Z-3A	1
4	Key - output gear	XKF4-4-14	1	XKF4-4-14	1	XKF4-4-14	1	XKF4-4-14	1	XKF4-4-14	1	XKF4-4-14	1
5	Output shaft ball bearing front	XBB-30-55-13M	1	XBB-30-55-13M	1	XBB-30-55-13M	1	XBB-30-55-13M	1	XBB-30-55-13M	1	XBB-30-55-13M	1
6	Output shaft ball bearing back	XBB-17-40-12M	1	XBB-17-40-12M	1	XBB-17-40-12M	1	XBB-17-40-12M	1	XBB-17-40-12M	1	XBB-17-40-12M	1
7	Oil seal-output	XOS-16-26-4	1	XOS-16-26-4	1	XOS-16-26-4	1	XOS-16-26-4	1	XOS-16-26-4	1	XOS-16-26-4	1
8	† Third reduction pinion	17T (84451)	1	16T (84450)	1	19T (84453)	1	-----	-	-----	-	16T (84450)	1
9	† Second reduction gear	91T (84447)	1	74T (84448)	1	82T (84449)	1	-----	-	-----	-	92T (84446)	1
10	Key-second reduction gear	XK3-3-8.5	1	XK3-3-8.5	1	XK3-3-8.5	1	-----	-	-----	-	XK3-3-8.5	1
11	Ball bearing-second reduction	XBB-17-40-12M	2	XBB-17-40-12M	2	XBB-17-40-12M	2	-----	-	-----	-	XBB-17-40-12M	2
12	Snap ring	XTR5100-81	1	XTR5100-81	1	XTR5100-81	1	-----	-	-----	-	XTR5100-81	1
13	† Second reduction pinion (Triple)	21T (84447)	1	22T (84448)	1	30T (84449)	1	-----	-	-----	-	20T (84446)	1
13A	† Second reduction pinion (Double)	-----	-	-----	-	-----	-	17T (84455)	1	18T (84452)	1	-----	-
14	† First reduction gear (Triple)	84T (84441)	1	80T (84442)	1	84T (84441)	1	-----	-	-----	-	88T (84440)	1
14A	† First reduction gear (Double)	-----	-	-----	-	-----	-	88T (84440)	1	84T (84441)	1	-----	-
15	Key - first reduction gear	XK3-3-8.5	1	XK3-3-8.5	1	XK3-3-8.5	1	XK3-3-8.5	1	XK3-3-8.5	1	XK3-3-8.5	1
16	Ball bearing-first reduction	XBB-17-40-12M	2	XBB-17-40-12M	2	XBB-17-40-12M	2	XBB-17-40-12M	2	XBB-17-40-12M	2	XBB-17-40-12M	2
17	† First reduction pinion	20T (84441)	1	24T (84442)	1	20T (84441)	1	16T (84440)	1	20T (84441)	1	16T (84440)	1
18	Ball bearing-input	XBB-25-52-15M	1	XBB-25-52-15M	1	XBB-25-52-15M	1	XBB-25-52-15M	1	XBB-25-52-15M	1	XBB-25-52-15M	1
19	Snap ring - input	XTRN5000-206	1	XTRN5000-206	1	XTRN5000-206	1	XTRN5000-206	1	XTRN5000-206	1	XTRN5000-206	1
20	Oil seal-input	XOS-18-32.75-5-V	1	XOS-18-32.75-5-V	1	XOS-18-32.75-5-V	1	XOS-18-32.75-5-V	1	XOS-18-32.75-5-V	1	XOS-18-32.75-5-V	1
21	Hex head capscrews	50064	1	50064	1	50064	1	50064	1	50064	1	50064	1
22	Allen head capscrew	XA518-12	4	XA518-12	4	XA518-12	4	XA518-12	4	XA518-12	4	XA518-12	4
23	Lockwasher	XLW-5A	4	XLW-5A	4	XLW-5A	4	XLW-5A	4	XLW-5A	4	XLW-5A	4
24	Motor flange	XG4Z-12	1	XG4Z-12	1	XG4Z-12	1	XG4Z-12	1	XG4Z-12	1	XG4Z-12	1
25	Lockwasher	XLW-5	8	XLW-5	8	XLW-5	8	XLW-5	8	XLW-5	8	XLW-5	8
26	Hex head capscrews (Hsg/Cover)	XL518-20	4	XL518-20	4	XL518-20	4	XL518-20	4	XL518-20	4	XL518-20	4
27	Gear cover	X4Z-31	1	X4Z-31	1	X4Z-31	1	X4Z-31	1	X4Z-31	1	X4Z-31	1
28	Gasket	XG4Z-40	1	XG4Z-40	1	XG4Z-40	1	XG4Z-40	1	XG4Z-40	1	XG4Z-40	1
29	Dowel pins	XDP516-12	2	XDP516-12	2	XDP516-12	2	XDP516-12	2	XDP516-12	2	XDP516-12	2
30	Key 1/4 SQ. X 1-1/4 LG	KEY-39K	1	KEY-39K	1	KEY-39K	1	KEY-39K	1	KEY-39K	1	KEY-39K	1
31	Pipe plugs	XSHPP-4	4	XSHPP-4	4	XSHPP-4	4	XSHPP-4	4	XSHPP-4	4	XSHPP-4	4
32	Vent plug	XVP-4-18M	1	XVP-4-18M	1	XVP-4-18M	1	XVP-4-18M	1	XVP-4-18M	1	XVP-4-18M	1
33	Nameplate	XNP-336	1	XNP-336	1	XNP-336	1	XNP-336	1	XNP-336	1	XNP-336	1
34	Nameplate tape	XNP-TAPE-3	1	XNP-TAPE-3	1	XNP-TAPE-3	1	XNP-TAPE-3	1	XNP-TAPE-3	1	XNP-TAPE-3	1
35	Label-oil	XLAB-49	1	XLAB-49	1	XLAB-49	1	XLAB-49	1	XLAB-49	1	XLAB-49	1
36	Flat Washer	XFW-5-SS	4	XFW-5-SS	4	XFW-5-SS	4	XFW-5-SS	4	XFW-5-SS	4	XFW-5-SS	4
▲	Anti-seize compound	XLT-1	1	XLT-1	1	XLT-1	1	XLT-1	1	XLT-1	1	XLT-1	1
▲	Cover-clear 2D Label	XLAB-2D-Cover	1	XLAB-2D-Cover	1	XLAB-2D-Cover	1	XLAB-2D-Cover	1	XLAB-2D-Cover	1	XLAB-2D-Cover	1
▲	2D Label-Blank	XLAB-2D-Blank	1	XLAB-2D-Blank	1	XLAB-2D-Blank	1	XLAB-2D-Blank	1	XLAB-2D-Blank	1	XLAB-2D-Blank	1

(▲) Not Shown

(†) REF.NO'S ( 2 & 8 ) , ( 9 & 13 ) , ( 14 & 13 ) USED ON TRIPLE REDUCTION RATIOS ORDERED AS KITS ONLY

(†) REF. NO'S ( 2 & 13A ) , AND ( 14A & 17 ) USED ON DOUBLE REDUCTION RATIO'S ORDERED AS KITS ONLY

# Dayton® Speed Reducers

---

## **LIMITED WARRANTY**

**DAYTON ONE-YEAR LIMITED WARRANTY.** Dayton Speed Reducers, Models covered in this manual, are warranted by Dayton Electric Mfg. Co. (Dayton) to the original user against defects in workmanship or materials under normal use for one year after date of purchase. Any part which is determined by Dayton to be defective in material or workmanship and returned to an authorized service location, as Dayton designates, shipping costs prepaid, will be, as the exclusive remedy, repaired or replaced at Dayton's option. For limited warranty claim procedures, see PROMPT DISPOSITION below. This limited warranty gives purchasers specific legal rights which vary from jurisdiction to jurisdiction.

**LIMITATION OF LIABILITY.** To the extent allowable under applicable law, Dayton's liability for consequential and incidental damages is expressly disclaimed. Dayton's liability in all events is limited to and shall not exceed the purchase price paid.

**WARRANTY DISCLAIMER.** Dayton has made a diligent effort to provide product information and illustrate the products in this literature accurately, however, such information and illustrations are for the sole purpose of identification, and do not express or imply a warranty that the products are MERCHANTABLE, or FIT FOR A PARTICULAR PURPOSE, or that the products will necessarily conform to the illustrations or descriptions. Except as provided below, no warranty or affirmation of fact expressed or implied, other than as stated in the "LIMITED WARRANTY" above is made or authorized by Dayton.

**PRODUCT SUITABILITY.** Many jurisdictions have codes and regulations governing sales, construction, installation, and/or use of products for certain purposes, which may vary from those in neighboring areas. While Dayton attempts to assure that its products comply with such codes, it cannot guarantee compliance, and cannot be responsible for how the product is installed or used. Before purchase and use of a product review the product applications, and all applicable national and local codes and regulations, and be sure that the product installation, and use will comply with them. Certain aspects of disclaimers are not applicable to consumer products, e.g., (a) some jurisdictions do not allow the exclusion or limitation of incidental or consequential damages, so the above limitation or exclusion may not apply to you, (b) also, some jurisdictions do not allow a limitation on how long an implied warranty lasts, consequently the above limitation may not apply to you, and (c) by law, during the period of this Limited Warranty, any implied warranties of implied merchantability or fitness for a particular purpose applicable to consumer products purchased by consumers, may not be excluded or otherwise disclaimed.

**PROMPT DISPOSITION.** Dayton will make a good faith effort for prompt correction or other adjustment with respect to any product which proves to be defective within limited warranty. For any product believed to be defective within limited warranty, first write or call dealer from whom the product was purchased. Dealer will give additional directions. If unable to resolve satisfactorily, write to Dayton at address below, giving dealer's name, address, date, and number of dealer's invoice, and describing the nature of the defect. Title and risk of loss pass to buyer on delivery to common carrier. If product was damaged in transit to you, file claim with carrier.

**Manufactured for Dayton Electric Mfg. Co., 5959 W. Howard St., Niles, Illinois 60714 U.S.A.**