

F9J"	97 B	89G7 F-DHC B	85H9	89G7 B9F
5		I dXUHYX A cXY ! 7 cffYWHX A cfcf8YdH k Ug%*) #&&#&\$%&	BUBW

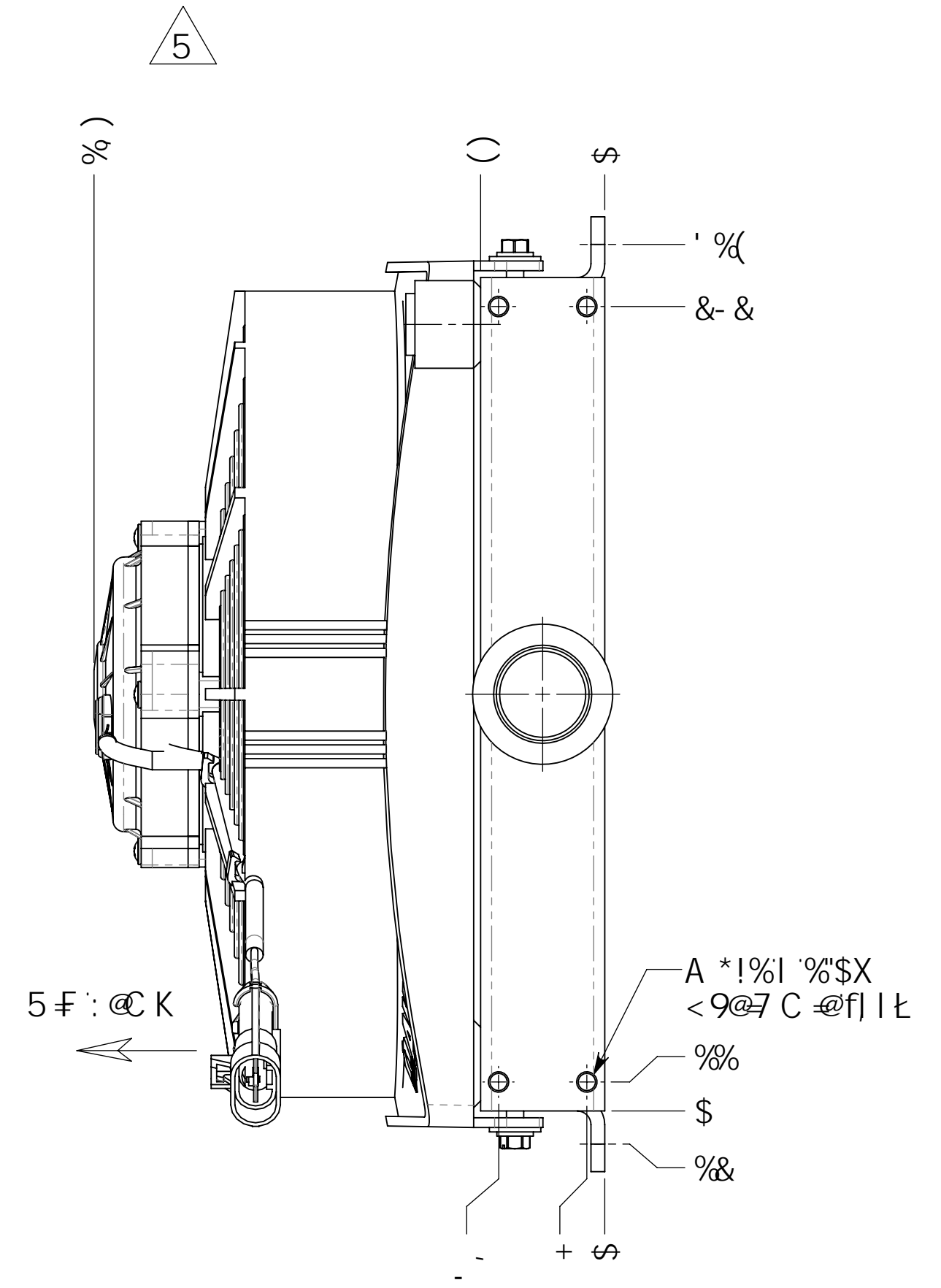
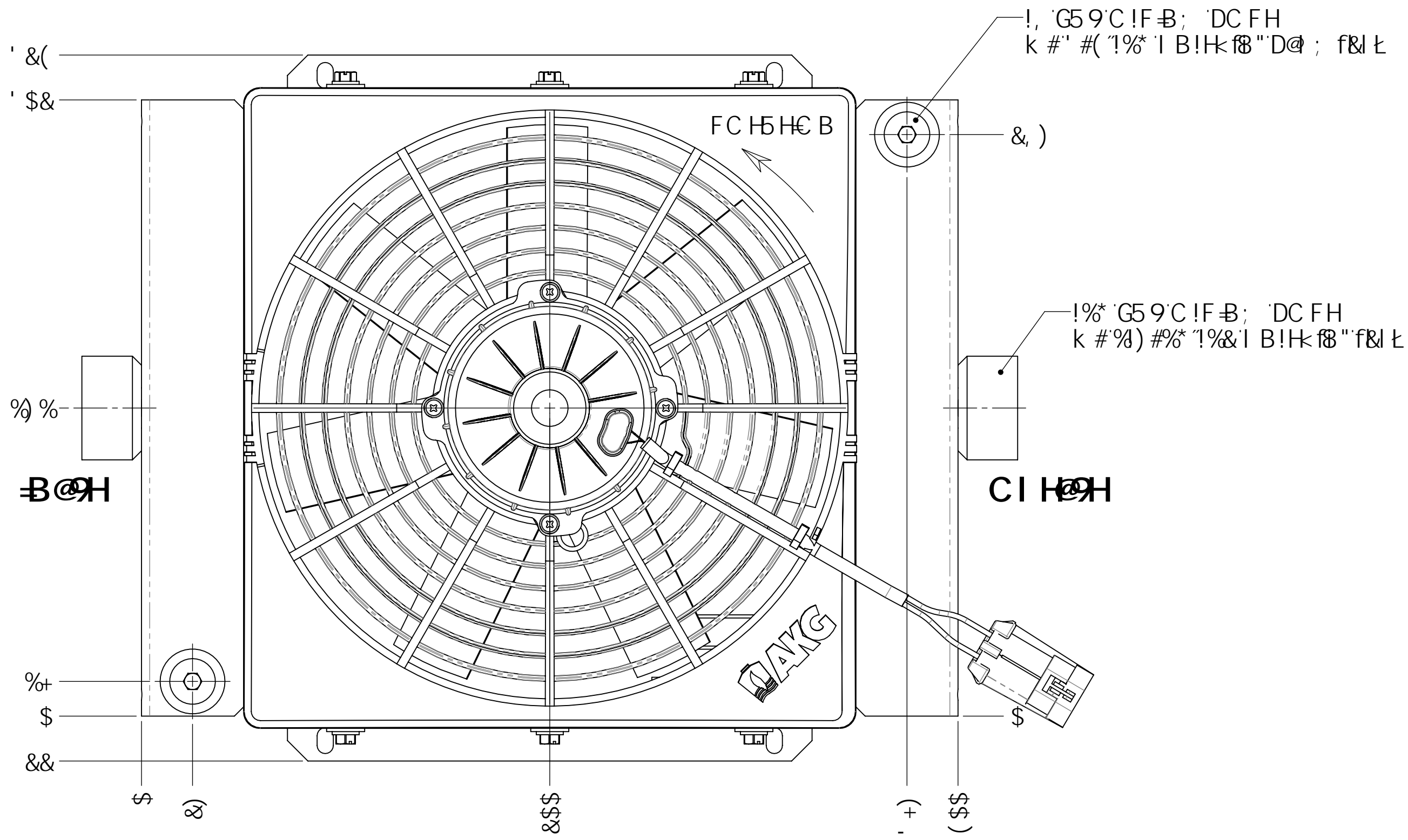
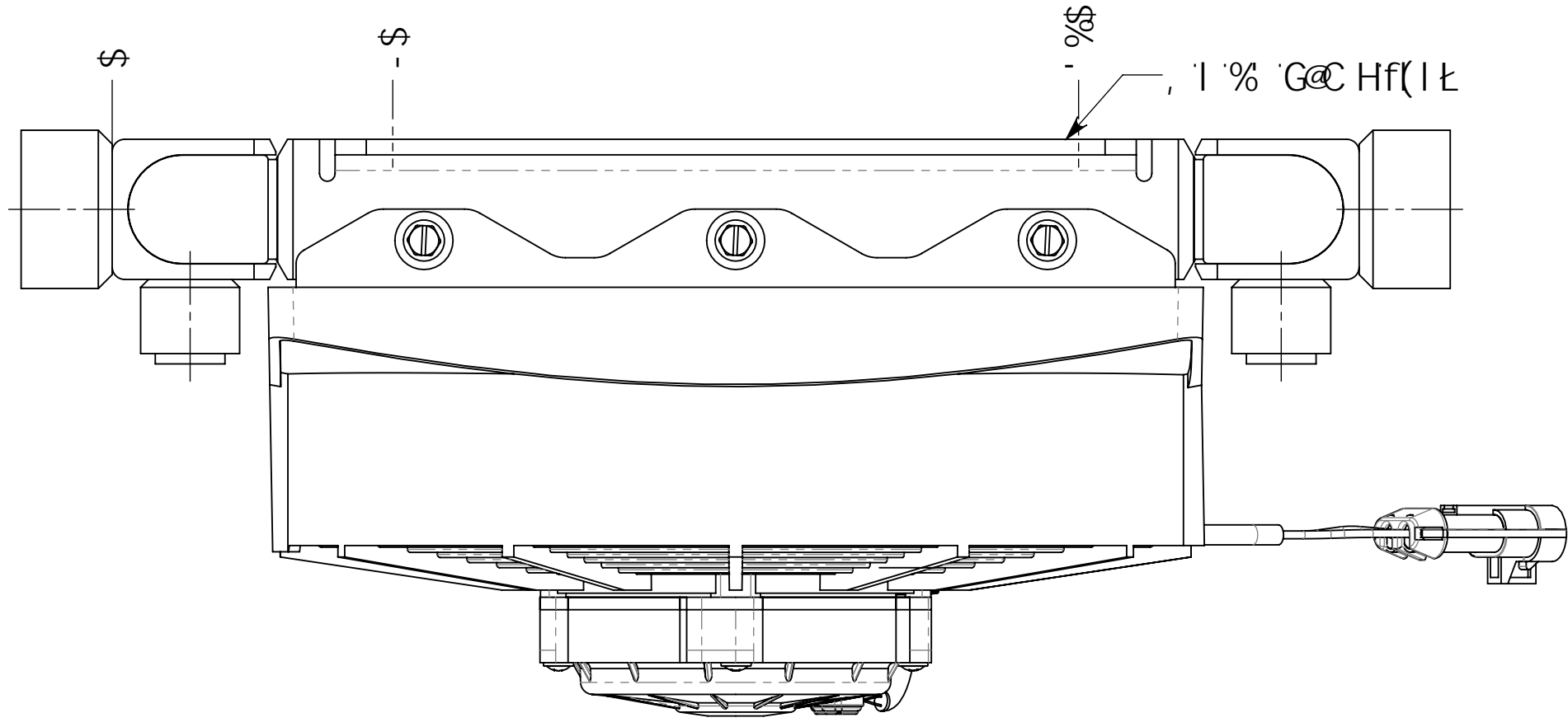

K c f_ dYgg fy fd gl: fA UI L	' ++	I B @GG' C Hk 9FK €9' GD97 ÷ 98
Hy ghDYgg fy fd gl: fA UI L	(')% "8]a YbgjcbgUfy 'a a "
A UI 'Hra dYfUH fy fB L	&) \$& "5 "X]a YbgjcbgUfy
DU]bh	6@7?fY ZYfybWw i bYgg
7i gca YfDUfhBc.	8%*!%&hc YfubWw jgdYWZYX"

AKG
 5?: 'H Yfa U`GngY a g
 DC '6CL % -
 A YVUbYzB7 '&+ '\$&
 D\cbYfl% L)*' ! (, +%
 : UI 'fl % L)*' ! (- %+

Hk 9-B: CFA 5HC B <9F9C B 'GHk 9DFC D9FHM	H+H@9
C: 5?: Hg' 5BM7CDMB: CF	
H5BGA #5@K #k CI HD9FA €GCB: FCA	
5?: C: 5A 9F-75 'GDFC <6+P8	
8FK B '6M	BUBW
85H9.	* #&' #-\$-
9B: F.	BUBW

	8%*!%&	
8K; "BC"	' +\$' "' \$, "\$\$\$\$	F9J"
D5; 9.	%cZ&	5

F9J GCB				
F9J "	97 B	8 9G7 F DHC B	85H9	8 9G# B 9F
!	!	GY Y G\YYH%	!	!

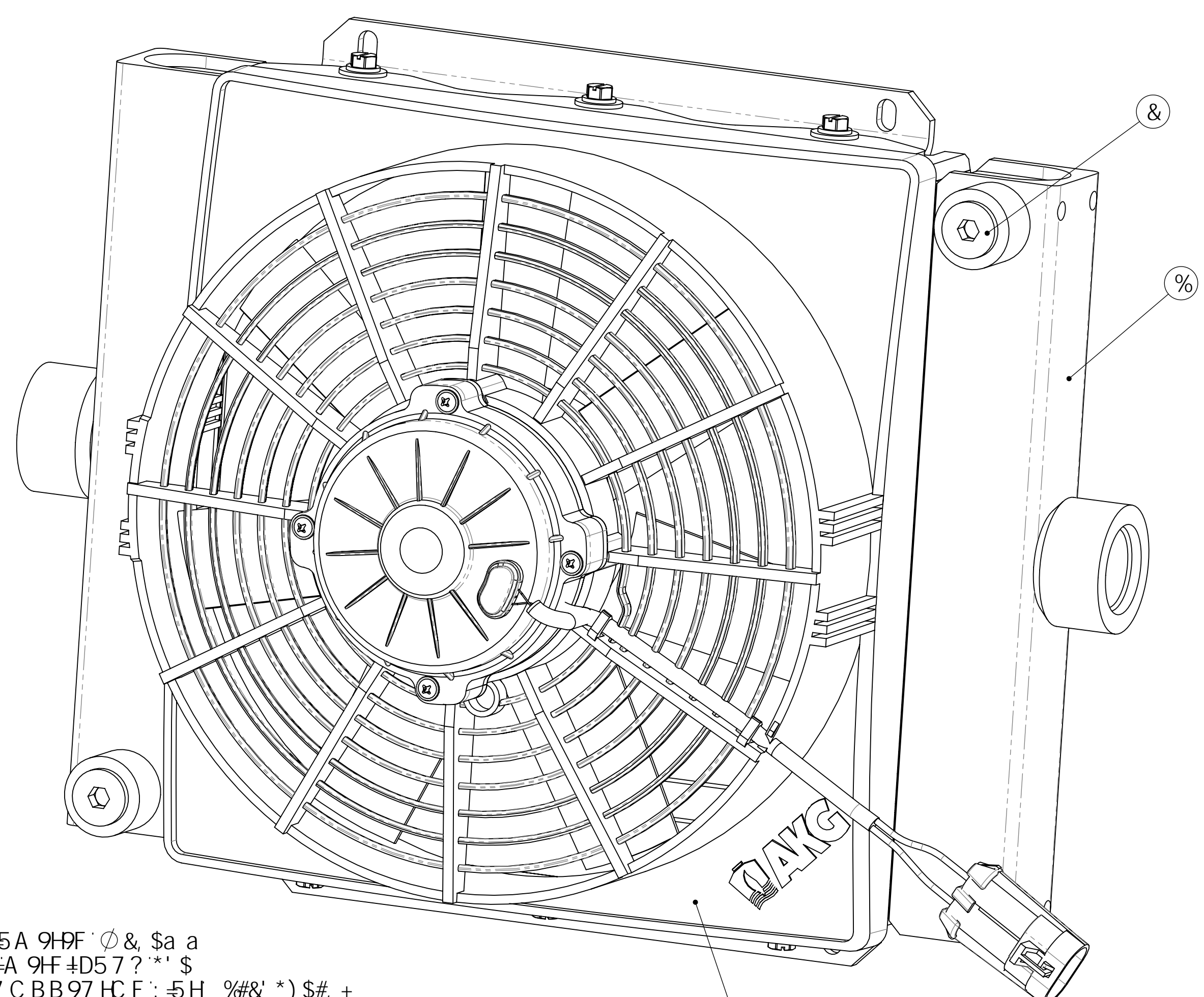

BC H9.
 % : 5B'8-5A 9H9F' & \$a a
 &" 89@<=A 9HF #D57? *' \$
 A 5@7CBB97HCF: 5H. %&'*) \$#, +
 A 5@9HFA B5@: 5H. %&'*) &#(('f&L
 G95@: 5H. %&'*) *#,) f&L
 G97CB85FM@ 7?: 5H. %&'(%' #, +
 ' " K #9. F98 Zz6@57?!
 (" F5H98 J C @5; 9. !%(J 87
)" BCFA 5@5A D'8F5K. %+±%\$!
 *" F97CA A 9B898: I G9.) \$'5A D

)	*	*\$\$-(,	G7F<L<8'Hk8:FA'##(!%'L')#," KN
(*	, \$) (" '\$' '\$\$\$\$\$	K 5G<9F!': @5H'##(%0'"GD5@: Ub'%'&j XW
'	%	, (\$+" * &"%\$+-	D'i [z!, 'G5'9C!F]b[
&	&	* '\$' "&+\$	8%'C @7CC @F
%	%	' +\$' "' \$, "%\$\$\$\$	8 9G7 F DHC B
#DA BC"	E HM	D5FHBI A 69F	

K c f_ dYgg fy fd gl: fA UI L	' ++	I B @GG' C Hk 9FK G9'GD97 ÷ 98
H y g h dYgg fy fd gl: fA UI L	(')%'8]a YbgjcbgUfy 'a a "
A UI 'Hra dYfUH fy f& L	&) \$&"5 "X]a YbgjcbgUfy'
DU]bh	6@57?fyZYfybWw' i bYgg
7i gca YfDUfhiBc.	8%!*&hc YfubWw 'jgdYWZYX"

5?: 'H Yfa U' GngY a g
 DC '6CL' % -
 A YVUbYzB7 '&+' \$&
 D\cbYfl% t) *' ! (, + %
 : UI 'fl % t) *' ! (- %+

Hk9-B: CFA 5HC B <9F9C B 'GH-9DFC D9FHM C: 5?: Hg'5BM7CDMB: CF' H5BGA #5@K #C I HD9FA GGC B: FCA 5?: C: 5A 9F-75 'GDFC <6+98	
8FK B'6M	BUBW
85H9.	* #&' #-\$-
9B: F.	BUBW

H+I@9	
8%!*!&	
8K; "BC"	F9J"
' +\$' "' \$, "\$\$\$\$\$	5
D5; 9.	&cZ&