



**MOM5**

UL Listed Sub-Assembly

Multi-Output Power Distribution Module



### Overview:

Altronix MOM5 is a UL Listed Sub-Assembly multi-output power distribution module that converts one (1) non power-limited DC voltage input to five (5) power-limited outputs. Each output will route power to a variety of access control hardware and devices that includes Mag Locks, Electric Strikes, Magnetic Door Holders, etc. These outputs will operate in both Fail-Safe and Fail-Secure modes. Controlled trigger input is achieved through normally open [NO] or normally closed [NC] supervised input or the polarity reversal from an FACP (Fire Alarm Control Panel). A form "C" dry output relay will enable HVAC Shutdown, Elevator Recall or trigger auxiliary devices.

### Specifications:

#### Agency Listings:

- UL Listed Sub-Assembly for Access Control System Units (UL 294) and Power Supplies for Fire Protective Signaling Systems (UL 1481). ULC-S318-96 - Power Supplies for Burglar Alarm Systems.
- Also suitable for Access Control.
- CE European Conformity.
- NFPA72 compliant.

#### Input:

- Fire Alarm Panel or Access Control System trigger inputs, [NO] or [NC] supervised trigger input and polarity reversal trigger input (rated 9-30VDC).

#### Outputs:

- Five (5) individual Class 2 Rated PTC protected power-limited outputs (auto-resettable).
- 12VDC or 24VDC operation.

#### Outputs (cont'd):

- Current limit is 2A @ 12VDC or 24VDC per output.

#### PTC Ratings:

- PTCs are rated @ 2A/250V.

#### Visual Indicators:

- Red LEDs indicate condition of each power output.
- Power and input trigger LEDs.

#### Supervision:

- Power fail supervision relay (Form "C" contact rated 1A @ 28VDC).

#### Additional Features:

- Output relay indicates that unit is triggered (Form "C" contact rated 1A @ 28VDC).
- Interfaces with most DC Power Supplies.

#### Board Dimensions (W x L x H approx.):

3.5" x 5.25" x 1"  
(88.9mm x 133.4mm x 25.4mm)

### Installation Instructions:

Wiring methods shall be in accordance with the National Electrical Code/NFPA 70/NFPA 72/ANSI, The Canadian Electrical Code, Part 1, and with all local codes and authorities having jurisdiction. Product is intended for indoor use only.

1. Refer to Sub-Assembly Installation Instructions for mounting Rev. MS050913.
2. Connect the DC output of the UL Listed power supply to the terminals marked [- DC INPUT +] carefully observing polarity.
3. Connect door strikes (Fail-Secure) positive to terminals marked [POS. (+) DC OUTPUT (ALARM)] [1] through [5] and negative to [NEG. 1] through [NEG. 5].
4. Connect door holders (fail-safe) positive to terminals marked [POS. (+) DC OUTPUT (STANDBY)] [6] through [10] and negative to [NEG. 1] through [NEG. 5].
5. To trigger the MOM5 from a FACP connect signaling circuit of FACP to terminals marked [-INPUT+] (*Fig. 1 - 7, pgs. 3 - 4*). Polarity is shown in alarm condition. Put wires coming to each terminal on different sides of the screw.
6. To trigger the MOM5 using a supervised dry contact connect the 2.2K resistor to terminals marked [TRIGGER] in series for a [NC] trigger input and in parallel for N.O. trigger input.
7. Connect the auxiliary devices that are to be triggered by the MOM5 to the terminals marked [NO & C] for normally open outputs and terminals marked [NC & C] for normally closed output. This relay will energize when the MOM5 is triggered.

8. Connect trouble reporting device to the terminals marked [POWER FAIL]. Connect to the [NO & C] for normally open and [NC & C] for normally closed output (*Fig. 3 - 7, pgs. 3 - 4*). This relay will switch when power is lost to the MOM5.

**Note:** This product is a UL Listed Sub-Assembly for use with Altronix UL Listed power supplies as indicated in the installation manuals for the power supply.

### **LED Diagnostic Table:**

<b>LED</b>	<b>ON</b>	<b>OFF</b>
<b>Power (Green)</b>	Normal operation.	Loss of power to MOM5.
<b>Trigger (Green)</b>	MOM5 triggered (alarm condition).	MOM5 in stand-by (non-alarm) condition.
<b>Outputs (Red)</b>	Output tripped due to a short circuit or overload condition.	Normal operation.

### **Terminal Identification:**

<b>Terminal Legend</b>	<b>Function/Description</b>
- DC Input +	12VDC or 24VDC from power supply.
Trigger	This circuit is supervised by a 2.2K EOL resistor. Initiating a short or open will cause power to be dropped to all terminals marked Pos. (+) DC output (stand-by) and supply power to all terminals marked Pos (+) DC output (alarm).
Input Neg (-), Pos (+)	Applying voltage to terminals marked Neg (-) input Pos (+) FACP signaling output in polarity shown will yield the same results as initiating trigger (mentioned above).
Neg (-) 1 through 5	Supplies constant negative (-) voltage.
Pos (+) DC output (alarm)	Supplies positive (+) voltage when dry input or fire alarm (wet) trigger input.
Pos (+) DC output (stand-by)	Supplies positive (+) voltage in normal condition. Power is removed when either input trigger is activated.
NC, C, NO Dry output	When the MOM5 is triggered terminals marked [C] and [NO] will open and the terminals marked [C] and [NC] will close. This output is used to trip auxiliary devices, e.g. HVAC Shutdown, Elevator Recall etc.
NC, C, NO Power Fail	Form "C" contacts used for signaling when no voltage is present at [- DC input +] terminals. Under normal conditions terminals marked [NO] and [C] are open, [NC] and [C] are closed. An occurrence of trouble condition causes terminals marked [NO] and [C] to close and terminals marked [NC] and [C] to open.

## Typical Application Diagrams:

Fig. 1

MOM5 module shown with wet and/or dry normally closed trigger inputs (**Non-Latching**):

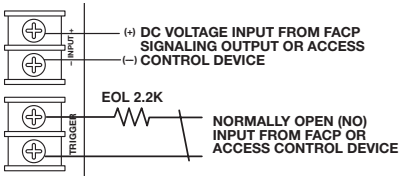

MOM5 module shown with wet and/or dry normally open trigger inputs (**Non-Latching**):

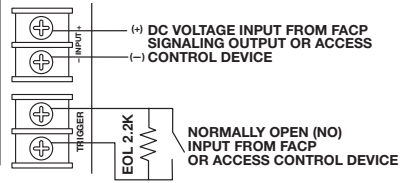

Fig. 2

Two (2) or more MOM5 modules shown with wet and/or dry normally closed trigger inputs (**Non-Latching**):

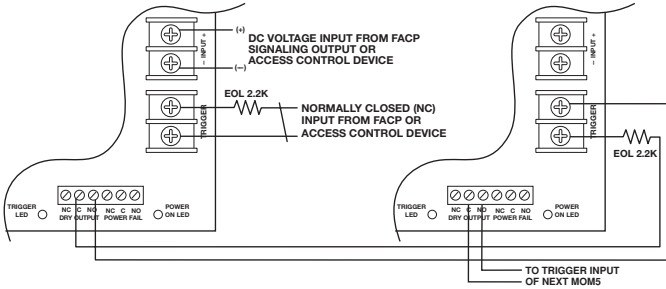

Fig. 3

Two (2) or more MOM5 modules shown with wet and/or dry normally open trigger inputs (**Non-Latching**):

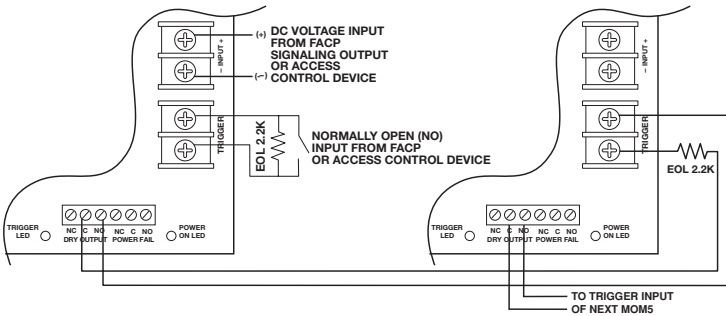
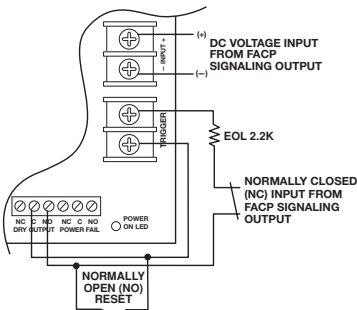

Fig. 4

MOM5 module shown with wet and/or dry normally closed fire alarm trigger inputs



MOM5 module shown with wet and/or dry normally open fire alarm trigger inputs

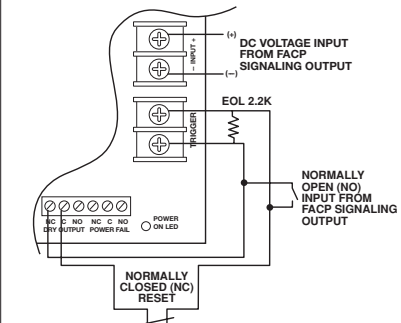

Fig. 5

Two (2) MOM5 modules shown with wet and/or dry normally closed fire alarm trigger inputs  
**(Latching with Manual Reset):**

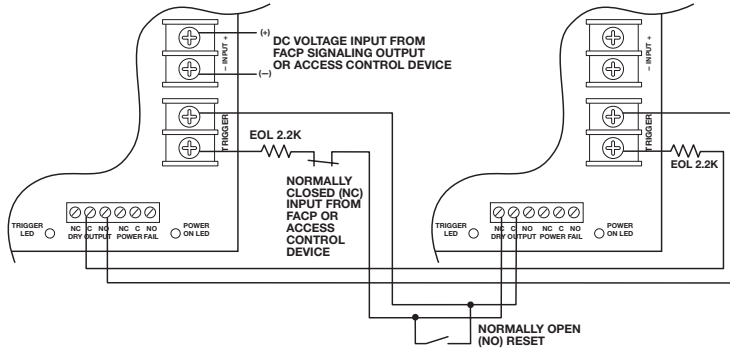

Fig. 6

Two (2) MOM5 modules shown with wet and/or dry normally open fire alarm trigger inputs  
**(Latching with Manual Reset):**

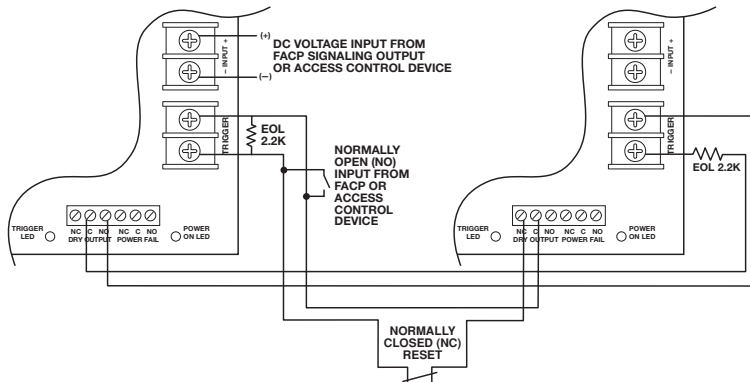
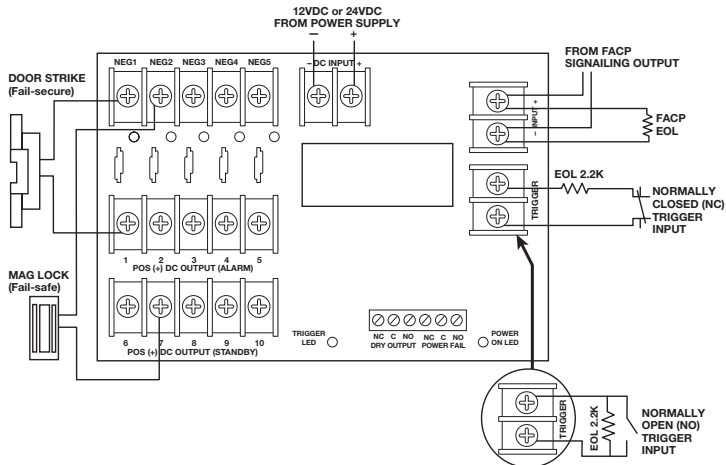

Fig. 7



Altronix is not responsible for any typographical errors.

140 58th Street, Brooklyn, New York 11220 USA | phone: 718-567-8181 | fax: 718-567-9056  
 website: www.altronix.com | e-mail: info@altronix.com | Lifetime Warranty | Made in U.S.A.  
 MOM5 Sub Assembly - 042811 K14Q



MOM5 Sub-Assembly