

# ***AT4/AT4B***

***Annual Event Timer***

***Installation Guide***

## Overview:

Altronix AT4/AT4B are extremely versatile 24 Hour 365 Day Event Timers designed to support a wide range of applications. Such applications include: Home and Building Automation, Security, Access Control, Lighting Control, etc.

AT4/AT4B are equipped with four independently controlled form “C” relay contacts that provide many latching and/or momentary operations during a program schedule of your choice. The EE prom memory allows for programming of unit prior to or during field installation. Events may be set for single or multiple operations on a daily and/or weekly schedule. The block programming feature enables repeating an event on any combination of consecutive days. AT4/AT4B will compensate for daylight savings time if desired. It automatically adjusts for leap year. Individually selected holiday exceptions can be programmed to override regularly scheduled events.

## Specifications:

### Input:

- 12 to 24 VAC or VDC operation.

### Relay:

- Standby current: 20mA with relays off combined with 40mA for each relay on.
- Four (4) Form “C” relay contacts are rated 10A @ 120VAC/28VDC.
- Each relay operates independently.

### Events/Programming:

- Momentary and/or Latching Events.
- 254 individually programmed daily/weekly events.
- Block programming capacity can accommodate a total of 1778 events per week.
- 254 programmable Holiday dates.

### Features:

- EE Prom memory protects against loss of programming due to power failure.
- Clock synchronization 60Hz (AC operation).
- Accurate crystal controlled clock (DC operation).

### Features (cont'd):

- “First man in” option.
- Standard or Daylight Savings Time settings.
- Automatic compensation for leap year.

### Battery Backup:

- Built-in charger for 12VDC sealed lead acid or gel type batteries (Max. charge current 300mA).
- Lithium battery backup maintains clock.  
Order Altronix part # LB2032.

### Display:

- Alphanumeric LCD display simplifies programming.

### Electrical:

- Operating temperature: -20° C to 49° C ambient.

### Mechanical:

- Enclosure Dimensions (H x W x D approx.):  
12” x 7.5” x 4.5” (304.8mm x 190.5mm x 114.3mm).
- Board Dimensions (L x W x H approx.):  
7” x 5.5” x 1.2” (177.8mm x 139.7mm x 30.48mm).

## Installation Instructions:

1. Mount AT4 enclosure in desired location.

### Carefully Review:

#### Basic Operation

#### Terminal Identification Table

#### Keyboard Layout and Description

#### Programming Instructions

(pg. 3)

(pg. 3)

(pg. 4)

(pgs. 5-6)

2. Connect 12 to 24 Volts AC or DC to terminals marked [- DC +]. When using DC carefully observe polarity.
3. Connect 12VDC battery (optional) to terminals marked [BAT -] and [BAT +].
4. Insert lithium battery (not supplied or required. Altronix part # LB2032) in battery holder as shown in Fig. 1, pg. 4 with the (+) positive side facing up.  
**Note:** Lithium Battery (LB2032) must only be installed after initial power up of AT4/AT4B.
5. Connect devices to be controlled to dry outputs marked RLY1 [NC, NO, C] - RLY4 [NC, NO, C]  
**Note:** It is important when connecting DC powered electromechanical devices such as Mag Locks, Electric Strikes, Bells, Relays, etc. to install a catch diode across the pos (+) and neg (-) terminals of the device. Connect diode as close to the device as possible with the banded side facing the pos (+) terminal. This will reduce the possibility of interference.
6. Program clock and desired event schedule (*Programming Instructions pg. 4-6*).

## **Basic Operation:**

AT4/AT4B controls four (4) independently operated dry form "C" relay outputs. Relays can be programmed to: turn on (latch), turn off (latch) or pulse (toggle) at a specified time and day (this is referred to as an event). Events are programmed via the keyboard and LCD display. These events can be designated to operate any one of the four (4) relays independently. Relay 1 corresponds to RL01, Relay 2 corresponds to RL02, etc. on the display. Events may be programmed to occur on any day of the week at any time. In addition, events may be repeated at a specific time on two (2) or more consecutive days (i.e. M-F, Sun-Th, etc) Multiple combinations of individual and block events may be programmed. Holiday exceptions are individually selected by date and will override all regularly scheduled events.

The four (4) output relay modes consist of:

**Relay OFF** - De-energizes the relay(s) selected until a relay On event is detected

**Relay ON** - Energizes the relay(s) selected until a Relay OFF event is detected.

**Disable** - Used to cancel and existing programmed event.

**Pulse** - Momentarily energizes the relay(s) for a selectable time period of 1 sec. to 15 sec.

Output relays are designated by the following:

**RL01** = Relay 1, **RL02** = Relay 2, **RL03** = Relay 3, **RL04** = Relay 4

Time is displayed in 24 hr. military format.

## **Terminal Identification:**

Terminal Legend	Function/Description
<b>RLY1: NC, NO, C</b>	Dry Contact output used to switch controlled devices.
<b>RLY2: NC, NO, C</b>	When these relays are energized (On) the NC and C terminals are open and the NO and C terminals are closed.
<b>RLY3: C, NC, NO</b>	When these relays are de-energized (Off) the NC and C terminals are closed and the NO and C terminals are open.
<b>RLY4: C, NC, N</b>	
<b>- DC +</b>	AC or DC Input 12 to 24 volt. When using DC carefully observe polarity.
<b>- BAT+</b>	12VDC standby battery input (battery leads provided).
<b>FM</b>	When this terminal is connected to DC neg. (-) the "First Man in" feature is enabled. All relays will remain in their present position until this connection is terminated. At that time relays will resume normal operation and latest scheduled events will occur

Fig. 1

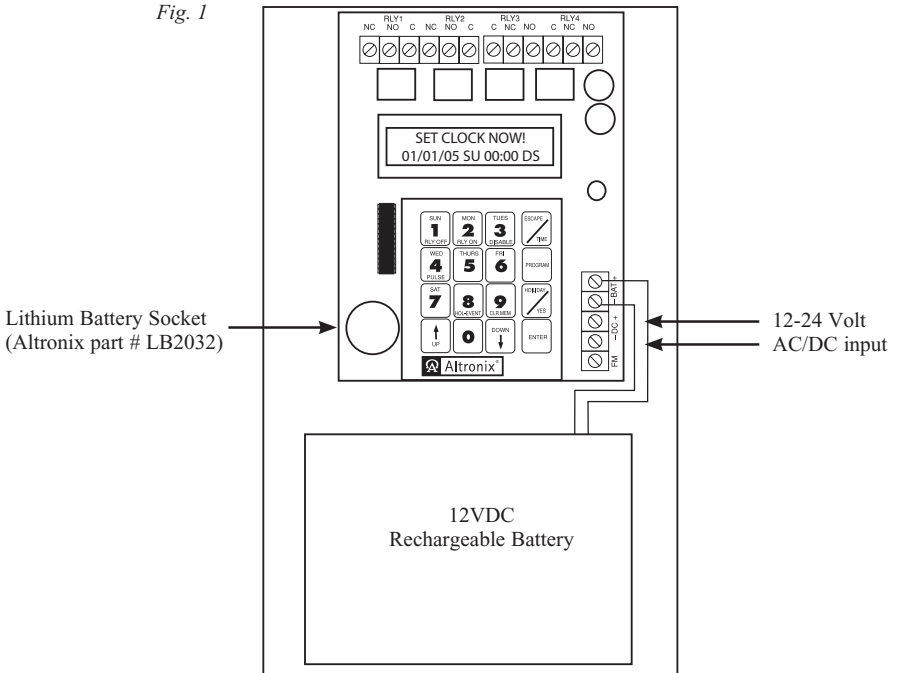

## Keyboard Layout:

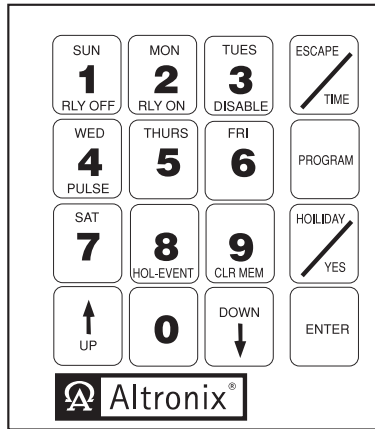

## Keyboard Description:

Key	Function/Description
<b>1</b>	Selects Sundays, Relay Off or numeral one (1)
<b>2</b>	Selects Monday, Relay On or numeral two (2)
<b>3</b>	Selects Tuesday, Relay Disable or numeral three (3)
<b>4</b>	Selects Wednesday, Relay Pulse or numeral four (4)
<b>5</b>	Selects Thursday or numeral five (5)
<b>6</b>	Selects Friday or numeral six (6)
<b>7</b>	Selects Saturday or numeral seven (7)
<b>8</b>	Selects Holiday Event or numeral (8)
<b>9</b>	Clears entire programmed memory or selects numeral (9)
<b>0</b>	Selects numeral (0)
<b>Up/Down</b>	Scrolling keys for programming
<b>Escape/Time</b>	Backspaces cursor when in programming mode, enables clock set mode, exit all program modes.
<b>Program</b>	Enables event programming.
<b>Holiday/Yes</b>	Enables holiday event selection. Confirms request to clear all previously programmed events.
<b>Enter</b>	Advances cursor when in programming mode.

**Note:** Most keys are multi-functional and will be used to input different information depending on the mode AT4/AT4B is in.

**UP** and **DOWN** keys can be used to select data entries.

After scrolling to the correct entry, depress **ENTER** to accept.

## Programming Instructions:

### A. Setting Clock/Calendar:

Upon initial power up SET CLOCK NOW!  
01/01/98 SU 00:00 DS will appear on display.

Enter today's date, present day of the week, current time (24 hr. military format) by depressing number keys.

**Note:** The flashing cursor denotes location of data entry selection to be made. If an entry was made in error or requires changing, depress either **ESCAPE** to backspace, or **ENTER** to accept data and advance the cursor. Now select either **DS** (daylight savings mode) by depressing **DOWN** or **ST** (standard time mode) by depressing **UP** followed by **ENTER**.

**Example:** To program 02/14/99 SU 10:25 am DS (daylight savings) depress the following sequence of keys:



To change or reprogram clock/calendar depress **TIME** and make new selections by repeating steps above.

### B. Setting Events:

Depress **PROGRAM** once. EVNT #0001^RL01 SU/SU  
RLY 00:00 will appear on display.

Depress **ENTER** until the flashing cursor reaches the RL01 display location. Select the output relay (RLY1 through RLY4) desired by depressing 1 through 4.

Next, select the day of week by depressing **SUN** through **SAT**. If this event is to occur on only one specific day, repeat the previous entry again.

**Note:** When it is required to have the same event repeated on two (2) or more consecutive days of the week (Block Programming), enter the first day followed by the last day by depressing **SUN** through **SAT**.

**Example:**

- 1) Monday through Thursday depress **MON** followed by **THURS**.
- 2) Wednesday through Sunday depress **WED** followed **SUN**.

Next select type of event required:

Depress **RLY OFF** for Relay OFF (Latching Mode)

Depress **RLY ON** for Relay ON (Latching Mode)

Depress **PULSE** for Relay PLS (Pulse/Toggle Mode)

When selecting Pulse/Toggle Mode it is necessary to assign the length of time (duration) of relay activation. The pulse can range in length from 1 second minimum to 15 seconds maximum by depressing the number keys 0 through 9.

**Note:** If pulse duration is not selected relay output defaults to 1 second.

Next select the time (military format) of day(s) event should occur by depressing the number keys 0 through 9. Depress **ENTER** to accept. Display automatically scrolls to the next event number to be programmed. You may continue to enter events by repeating the previous steps or exit programming by depressing **ESCAPE**.

**Note:** When programming additional events it is necessary to select the next consecutive event number following the last event programmed to continue.

**Example:** To program event #1 to cause Relay 2 to Toggle/Pulse for five (5) seconds on both Sat. and Sun. at 11:59 pm, depress the following sequence of keys:



#### C.1 Setting Holiday Events:

Depress **PROGRAM** once. Select the next available event number by depressing keys 0 through 9.

Depress **ENTER** until the flashing cursor reaches the RL01 display location. Select the output relay (RLY01 through RLY04) desired by depressing 1 through 4. Next depress **HOL-EVENT**.

HL/HL will appear on the display designating this event as a holiday.

**Note:** When a holiday event is entered, all holidays will follow that event.

Next select type of event required:

Depress **RLY OFF** for Relay OFF (Latching Mode)

Depress **RLY ON** for Relay ON (Latching Mode)

Depress **PULSE** for Relay PLS (Pulse/Toggle Mode)

When selecting the Pulse/Toggle mode it is necessary to assign the length of time (duration) of relay activation. The pulse can range in length from 1 second minimum to 15 seconds maximum by depressing the number keys **0** through **9**.

**Note:** If pulse duration is not selected relay output defaults to 1 second.

Next selecting the Pulse/Toggle mode it is necessary to assign the length of time (duration) of relay activation. The pulse can range in length from 1 second minimum to 15 seconds maximum by depressing the number keys **0** through **9**. Depress **ENTER** to accept. Display automatically scrolls to the next event number to be programmed. Exit programming by depressing **ESCAPE**.

**Note:** When a holiday event is entered, all the holidays will follow that event.

**Example:** To program holiday event #2 to cause Relay 2 to Latch (Relay On) at 08:00AM depress the following sequence of keys:



**Note:** Holiday events will always override any regularly scheduled events.

### C.2 Setting Holiday Dates:

It is now necessary to assign these holiday events specific calendar dates which they are to occur. To set holiday event dates depress **HOLIDAY/YES** once. HOL #0001 01/01/01 will appear on display.

Depress **ENTER** until the flashing cursor reaches the date display location. Next make your selection by depressing the number keys **0** through **9**. You may continue to add holiday event dates by repeating the previous steps or exit programming by depressing **ESCAPE**. If no holiday event has been entered and a holiday date is entered, the unit will stay in its last position when that date comes up.

**Example:** To program holiday events to occur on Dec. 25, 2000 depress the following sequence of keys:



You may continue to program the next holiday date or depress **ESCAPE** to exit.

### D. Delete/Disable Events or Edit Events:

Previously programmed regularly scheduled and/or holiday events may be deleted/disabled without having to erase all events. To proceed depress **PROGRAM** once. Locate the event number by depressing the number keys **0** through **9**. When cursor is flashing under ^ symbol in display, scrolling feature is activated. By depressing **UP** you can scroll through all the events programmed. If any event needs to be modified or disabled depress **ENTER**. Next, depress **ENTER** until flashing cursor reaches the RLY display location. Depress **DISABLE** and RLY DIS will appear on display. Depress **ENTER** until the next event number appears to accept modification. Repeat the previous steps above to locate and disable other events or depress **ESCAPE** to exit.

Previously programmed regular and/or Holiday events may be edited by depressing **PROGRAM** once. Locate the event number by depressing the number keys **0** through **9** or scroll using the **UP** key. Proceed to make any changes (i.e. RL#, Day, Relay Event Type, Time) and depress **ESCAPE** to exit.

### E. Delete All Events:

All previously programmed events can be deleted by simply depressing **CLR MEM**.

CLEAR ALL EVENTS? will appear on display. Accept by depressing **YES** followed by **1** to confirm deletion.



