

# Dimensional Drawing

**4NXG3BG**

REV.

-

VAR	MODEL	CUST. PT. NO.	A	B	C	D	HP	VOLTS	SF	AMPS	HZ	RPM	CONN VOLTS	PROT.	DESCRIPTION / REMARKS
001	T63ZZBKN-2230	4NXG3BG	12.39	---	---	---	1.0	115/208-230	1.15	10.9/5.4-5.4	60	1725	---	AUTO	N56, TEAD, GREEN

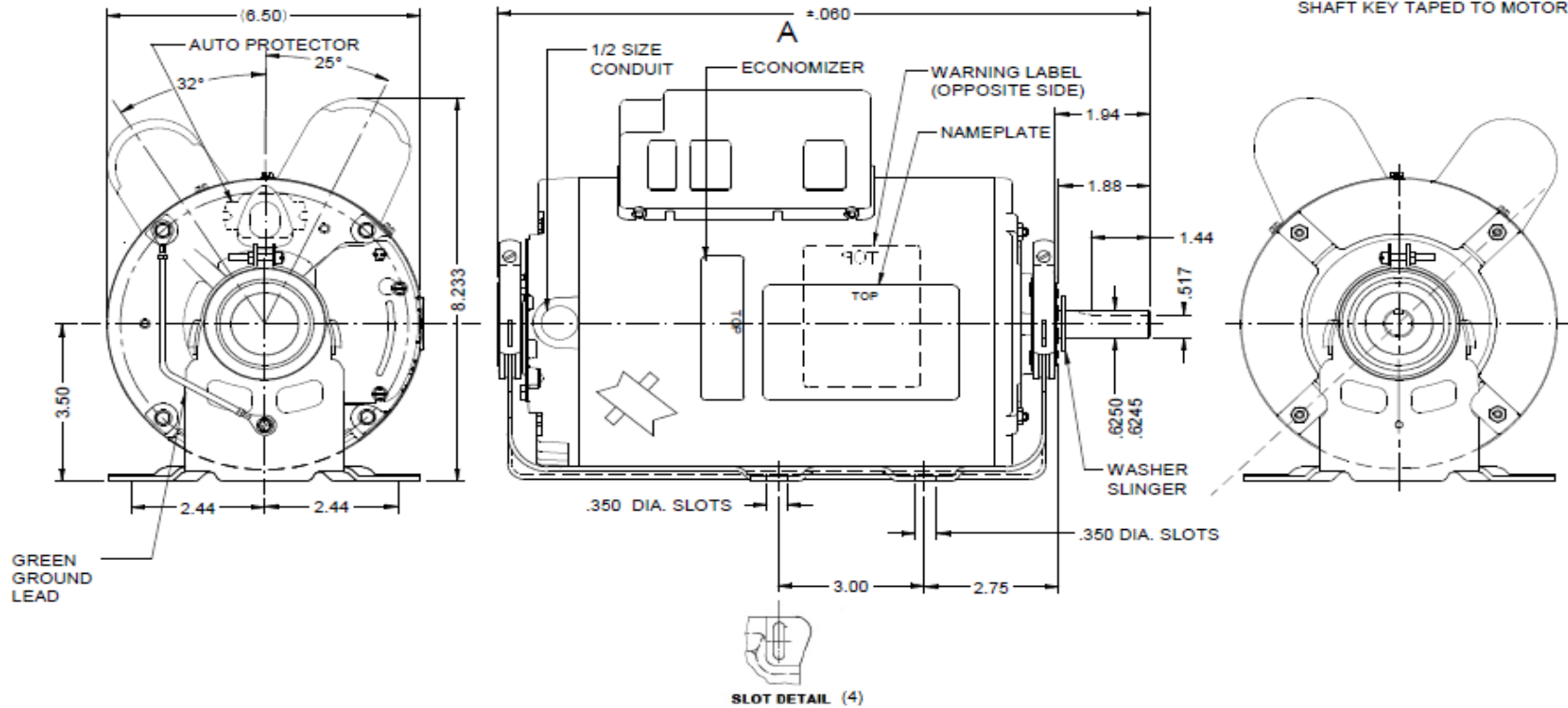

DRAWING NO. PAGE 1 of 1 REV.  
**4NXG3BG** -

# Performance Data



**4NXG3BG**

REV.  
-

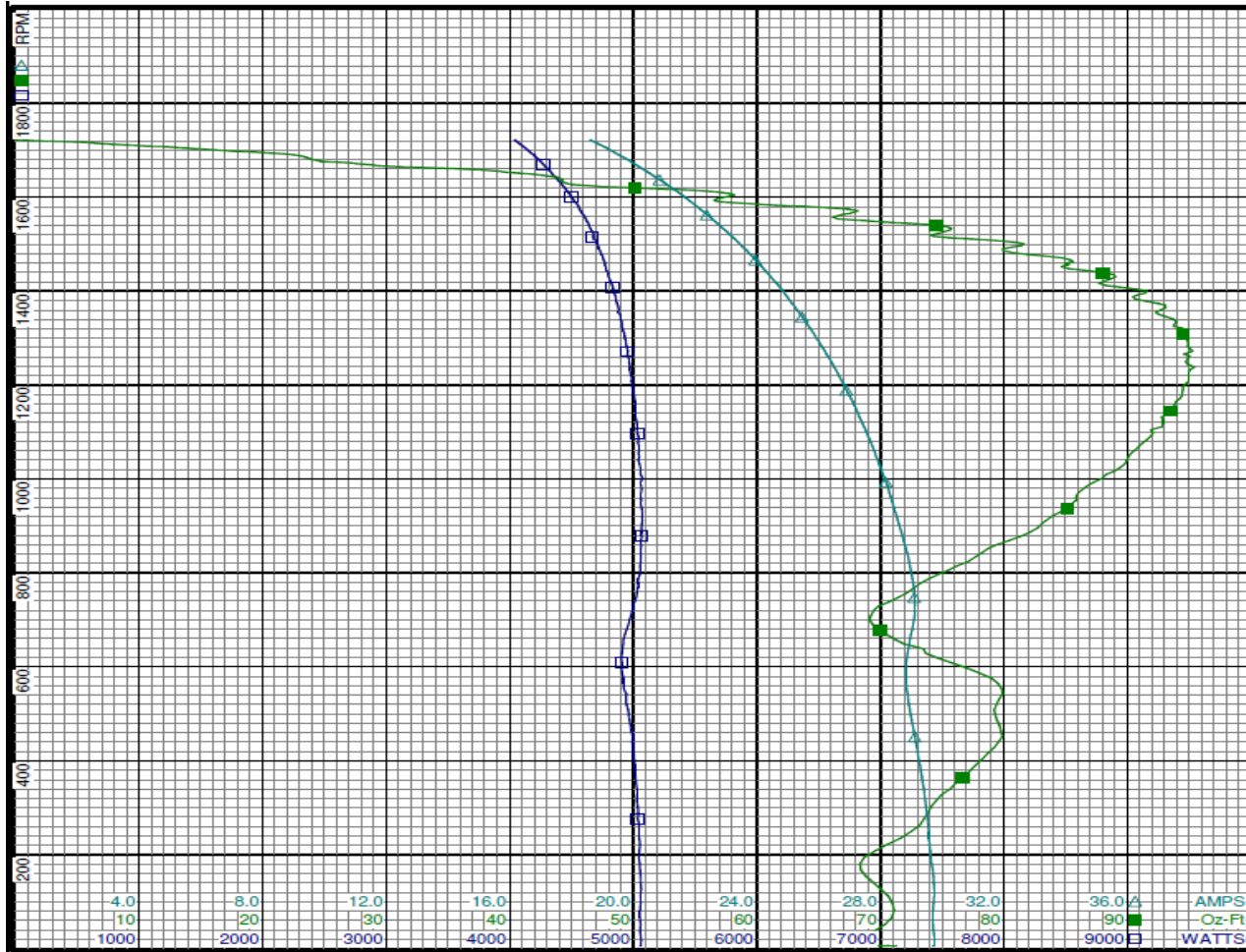

**Curve Descriptions:**  
Motor(1) Test 6 Start 230V 60 Hz 4P

- SPEED vs WATTS
- SPEED vs TORQUE
- △ SPEED vs ILine

**Motor Ratings:**  
(1) T063BKN2230 4NXG3BG

DRAWING NO. PAGE 1 of 2 REV.  
**4NXG3BG** -

Dayton Electric Mfg. Co. Lake Forest, IL 60045 USA

©2018 W.W. Grainger, Inc. This design may not be reproduced, modified or redistributed without written permission from W.W. Grainger, Inc.

**4NXG3BG**

REV.

-

## Dayton Manufacturing Company

**Motor Description**

Model: T063BKN2230 4NXG3BG  
 Motor ID: 1  
 Poles: 4  
 Volts: 115/208-230  
 Frequency: 60  
 HP: 1.0  
 Speed: 1725  
 Phase: 1  
 Protector: CEJ64CS

**Test Conditions**

Test Type: Start  
 Test Number: 6  
 Poles: 4  
 Volts: 230  
 Hz: 60  
 Rotation:  
 Special Cond:  
 Speed Conn:  
 TestBoard: Amtps Performance Fixture #2  
 Run Cap: 15 µFd  
 Start Cap: 208 µFd  
 Environment:  
 Tested: 7/24/2014 2:34:17 PM  
 Tested By: Sharp, Gerald  
 Gear Ratio: 1:1  
 Bearing Friction: -0.80 Oz-Ft  
 Windage Torque: -2.56 Oz-Ft

Special Points	Vline (V)	Vaux (V)	Vcap (V)	Iline (A)	Imain (A)	Iaux (A)	Watts	RPM	Tq(Oz-ft)	HP	Eff(%)	PF(%)	Cap
	230.0	223.5	91.3	29.73	26.37	6.875	5059	6	71.32	0.005	0.1	74.0	199.7
<b>PUT OZ-FT</b>	<b>230.0</b>	<b>222.5</b>	<b>91.4</b>	<b>29.73</b>	<b>26.40</b>	<b>6.876</b>	<b>5058</b>	<b>11</b>	<b>68.29</b>	<b>0.009</b>	<b>0.1</b>	<b>74.0</b>	<b>199.5</b>
	230.0	218.6	91.2	29.73	26.37	6.865	5058	26	68.78	0.021	0.3	74.0	199.6
	230.0	224.9	88.2	29.71	26.20	6.624	5056	153	68.84	0.125	1.9	74.0	199.1
	230.0	228.9	85.7	29.52	25.82	6.437	5036	276	73.50	0.241	3.6	74.2	199.2
	230.0	231.0	83.1	29.28	25.44	6.240	5012	389	77.66	0.360	5.4	74.4	199.2
	230.0	234.0	79.3	28.97	25.09	5.951	4961	497	79.29	0.469	7.1	74.4	199.1
	230.0	236.9	74.2	28.83	24.88	5.560	4904	598	76.94	0.547	8.3	74.0	198.7
	230.0	244.8	72.5	29.05	24.68	5.426	4960	690	69.37	0.569	8.6	74.2	198.7
	230.0	251.0	74.3	29.06	24.15	5.576	5038	778	73.25	0.678	10.0	75.4	199.0
	230.0	257.7	75.1	28.79	23.56	5.634	5065	860	79.43	0.813	12.0	76.5	198.9
	230.0	263.0	75.7	28.44	23.13	5.686	5069	937	85.15	0.950	14.0	77.5	199.2
	230.0	267.6	76.4	28.08	22.52	5.741	5058	1009	88.25	1.060	15.6	78.3	199.2
	230.0	269.7	77.4	27.69	21.92	5.816	5038	1076	91.20	1.168	17.3	79.1	199.3
	230.0	277.5	79.0	27.28	21.30	5.937	5019	1138	93.18	1.263	18.8	80.0	199.4
	230.0	280.3	81.1	26.85	20.68	6.102	4990	1196	94.48	1.345	20.1	80.8	199.5
	230.0	288.8	83.8	26.40	20.05	6.307	4965	1250	94.70	1.409	21.2	81.8	199.6
	230.0	294.5	87.0	25.93	19.41	6.551	4932	1299	94.77	1.466	22.2	82.7	199.8
	230.0	294.6	90.6	25.47	18.77	6.836	4895	1345	93.13	1.491	22.7	83.6	200.1
	230.0	305.7	94.9	24.98	18.14	7.155	4857	1388	90.44	1.494	22.9	84.5	200.0
	230.0	307.6	99.0	24.51	17.54	7.481	4808	1425	88.58	1.503	23.3	85.3	200.4
	230.0	316.2	103.9	24.00	16.91	7.867	4767	1463	85.57	1.490	23.3	86.4	200.8
	230.0	320.6	108.9	23.50	16.30	8.242	4712	1496	81.41	1.450	23.0	87.2	200.8
	230.0	326.8	113.4	23.03	15.79	8.588	4666	1526	75.15	1.365	21.8	88.1	200.8
	230.0	332.3	118.9	22.50	15.22	9.011	4607	1557	66.17	1.226	19.9	89.0	201.0
	230.0	337.6	123.9	22.01	14.71	9.415	4553	1582	61.57	1.160	19.0	90.0	201.5
	230.0	343.2	128.9	21.52	14.26	9.783	4481	1606	57.92	1.108	18.4	90.5	201.4
	230.0	347.8	133.8	21.03	13.82	10.168	4415	1630	44.42	0.862	14.6	91.3	201.5
	230.0	352.0	138.9	20.51	13.40	10.566	4338	1651	40.69	0.800	13.8	92.0	201.7
	230.0	357.7	143.6	20.02	13.03	10.944	4267	1671	27.59	0.549	9.6	92.6	202.1
	230.0	360.9	148.5	19.53	12.70	11.332	4198	1690	22.46	0.452	8.0	93.5	202.4
	230.0	369.3	153.8	19.01	12.37	11.735	4106	1708	10.74	0.218	4.0	93.9	202.4
	230.0	371.4	157.4	18.60	12.16	12.011	4037	1722	0.00	0.000	0.0	94.4	202.4

# Performance Data



**4NXG3BG**

REV.  
-

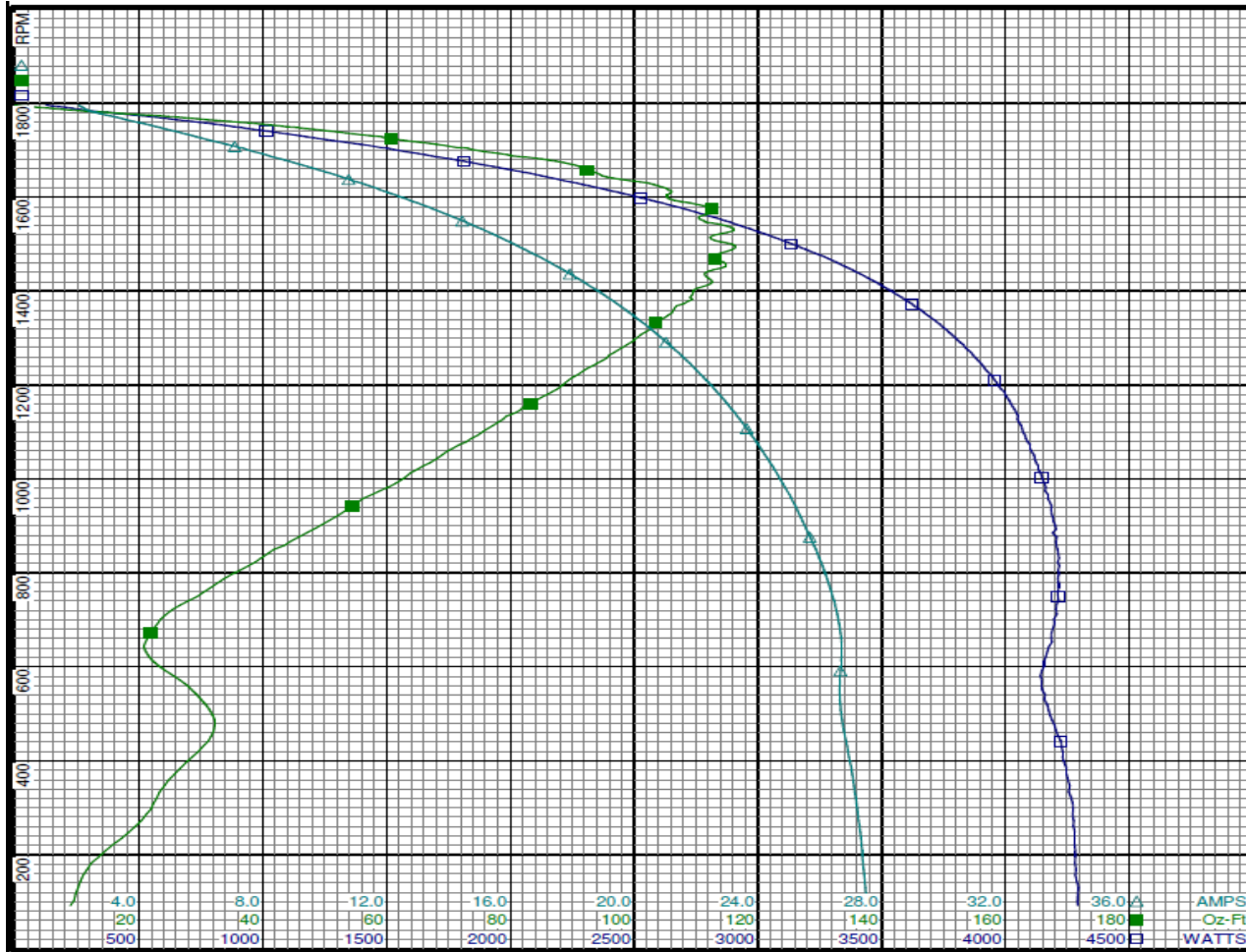

Curve Descriptions:  
Motor(1) Test 7 Run 230V 60 Hz 4P

- SPEED vs WATTS
- SPEED vs TORQUE
- △ SPEED vs ILine

Motor Ratings:  
(1) T063BKN2230 4NXG3BG

DRAWING NO.	PAGE 2 of 2	REV.
4NXG3BG		-

Dayton Electric Mfg. Co. Lake Forest, IL 60045 USA

©2018 W.W. Grainger, Inc. This design may not be reproduced, modified or redistributed without written permission from W.W. Grainger, Inc.

# Performance Data



## 4NXG3BG

REV.

-

### Motor Description

Model: T063BKN2230 4NXG3BG  
 Motor ID: 1  
 Poles: 4  
 Volts: 115/208-230  
 Frequency: 60  
 HP: 1.0  
 Speed: 1725  
 Phase: 1  
 Protector: CEJ64CS

### Test Conditions

Test Type: Run  
 Test Number: 7  
 Poles: 4  
 Volts: 230  
 Hz: 60  
 Rotation:  
 Special Cond:  
 Speed Conn:  
 TestBoard: Amtps Performance Fixture #2  
 Run Cap: 15 µFd  
 Start Cap: 208 µFd  
 Environment:  
 Tested: 7/24/2014 3:10:52 PM  
 Tested By: Sharp, Gerald  
 Gear Ratio: 1:1  
 Bearing Friction: -0.64 Oz-Ft  
 Windage Torque: -2.40 Oz-Ft

Special Points	Vline (V)	Vaux (V)	Vcap (V)	Iline (A)	Imain (A)	Iaux (A)	Watts	RPM	Tq(Oz-ft)	HP	Eff (%)	PF (%)	Cap
	230.0	275.2	277.1	2.06	2.81	1.573	122	1796	0.00	0.000	0.0	25.9	15.1
	230.0	275.8	263.4	2.82	2.67	1.489	446	1776	19.30	0.408	68.2	68.8	15.0
	230.0	274.0	252.8	3.94	3.36	1.435	743	1759	36.36	0.761	76.4	82.0	15.1
<b>48.6 OZ-FT</b>	<b>230.0</b>	<b>270.8</b>	<b>244.4</b>	<b>4.93</b>	<b>4.20</b>	<b>1.389</b>	<b>970</b>	<b>1743</b>	<b>48.60</b>	<b>1.009</b>	<b>77.6</b>	<b>85.5</b>	<b>15.1</b>
<b>1 HP</b>	<b>230.0</b>	<b>270.8</b>	<b>244.7</b>	<b>4.89</b>	<b>4.17</b>	<b>1.390</b>	<b>961</b>	<b>1744</b>	<b>48.17</b>	<b>1.000</b>	<b>77.7</b>	<b>85.4</b>	<b>15.1</b>
	230.0	270.4	242.9	5.12	4.37	1.381	1015	1740	50.71	1.051	77.2	86.1	15.1
<b>1.15 HP</b>	<b>230.0</b>	<b>269.0</b>	<b>238.9</b>	<b>5.59</b>	<b>4.81</b>	<b>1.362</b>	<b>1119</b>	<b>1733</b>	<b>55.75</b>	<b>1.150</b>	<b>76.6</b>	<b>87.1</b>	<b>15.1</b>
<b>56 OZ-FT</b>	<b>230.0</b>	<b>268.9</b>	<b>238.8</b>	<b>5.61</b>	<b>4.83</b>	<b>1.361</b>	<b>1124</b>	<b>1732</b>	<b>56.00</b>	<b>1.155</b>	<b>76.6</b>	<b>87.1</b>	<b>15.1</b>
<b>1725 RPM</b>	<b>230.0</b>	<b>267.7</b>	<b>235.4</b>	<b>6.03</b>	<b>5.23</b>	<b>1.344</b>	<b>1219</b>	<b>1725</b>	<b>60.28</b>	<b>1.238</b>	<b>75.8</b>	<b>87.8</b>	<b>15.1</b>
	230.0	266.8	232.9	6.32	5.51	1.330	1283	1720	63.03	1.291	75.0	88.3	15.2
	230.0	262.2	222.5	7.59	6.77	1.272	1554	1699	74.84	1.514	72.7	89.0	15.2
	230.0	257.6	212.5	8.84	8.02	1.219	1811	1676	87.37	1.744	71.8	89.1	15.2
	230.0	253.1	202.7	10.07	9.28	1.169	2058	1652	93.65	1.842	66.8	88.9	15.3
	230.0	247.6	192.9	11.29	10.54	1.115	2290	1627	103.09	1.996	65.0	88.2	15.3
	230.0	242.1	182.9	12.52	11.84	1.059	2527	1598	105.33	2.004	59.2	87.8	15.4
	230.0	236.6	173.3	13.73	13.10	1.008	2743	1569	112.81	2.107	57.3	86.9	15.4
	230.0	230.5	163.7	14.93	14.36	0.954	2949	1535	115.64	2.113	53.5	85.9	15.5
<b>BDT OZ-FT</b>	<b>230.0</b>	<b>224.3</b>	<b>154.6</b>	<b>16.10</b>	<b>15.59</b>	<b>0.902</b>	<b>3136</b>	<b>1500</b>	<b>115.73</b>	<b>2.066</b>	<b>49.2</b>	<b>84.7</b>	<b>15.5</b>
	<b>230.0</b>	<b>223.2</b>	<b>152.7</b>	<b>16.34</b>	<b>15.83</b>	<b>0.892</b>	<b>3173</b>	<b>1493</b>	<b>116.33</b>	<b>2.067</b>	<b>48.6</b>	<b>84.4</b>	<b>15.5</b>
	230.0	218.1	145.6	17.27	16.81	0.852	3318	1461	114.47	1.991	44.8	83.5	15.5
	230.0	211.8	137.4	18.37	17.97	0.805	3477	1419	112.67	1.903	40.8	82.3	15.5
	230.0	205.4	129.6	19.45	19.10	0.760	3622	1373	107.97	1.764	36.3	81.0	15.6
	230.0	199.1	122.6	20.46	20.18	0.719	3747	1323	102.99	1.622	32.3	79.6	15.6
	230.0	192.8	116.4	21.42	21.20	0.682	3861	1269	96.75	1.461	28.2	78.4	15.5
	230.0	186.8	111.0	22.33	22.16	0.655	3956	1210	89.38	1.288	24.3	77.0	15.7
	230.0	180.7	106.3	23.17	23.05	0.625	4037	1147	81.61	1.114	20.6	75.8	15.6
	230.0	174.8	102.8	23.94	23.68	0.606	4091	1078	72.79	0.934	17.0	74.3	15.6
	230.0	169.3	99.9	24.67	24.46	0.587	4147	1004	63.09	0.754	13.6	73.1	15.6
	230.0	163.9	97.6	25.32	25.16	0.574	4187	926	52.63	0.580	10.3	71.9	15.6
	230.0	159.5	95.5	25.92	25.79	0.559	4213	840	40.81	0.408	7.2	70.7	15.5
	230.0	155.0	93.3	26.42	26.32	0.542	4213	749	29.30	0.261	4.6	69.3	15.4
	230.0	150.2	91.1	26.70	26.65	0.530	4188	652	21.01	0.163	2.9	68.2	15.4
	230.0	139.6	96.1	26.64	26.67	0.554	4147	552	28.41	0.187	3.4	67.7	15.3
	230.0	130.7	104.2	26.85	26.91	0.596	4224	442	31.15	0.164	2.9	68.4	15.2
	230.0	126.3	107.8	27.16	27.25	0.613	4265	321	22.86	0.087	1.5	68.3	15.1
	230.0	122.3	110.0	27.37	27.50	0.626	4283	195	13.45	0.031	0.5	68.0	15.1
<b>PUT OZ-FT</b>	<b>230.0</b>	<b>274.4</b>	<b>269.9</b>	<b>2.32</b>	<b>2.63</b>	<b>1.522</b>	<b>276</b>	<b>1785</b>	<b>8.87</b>	<b>0.188</b>	<b>50.8</b>	<b>51.5</b>	<b>15.0</b>

DRAWING NO.	PAGE 2 of 2	REV.
	4NXG3BG	-

**4NXG3BG**

REV.  
0

## CONNECTIONS

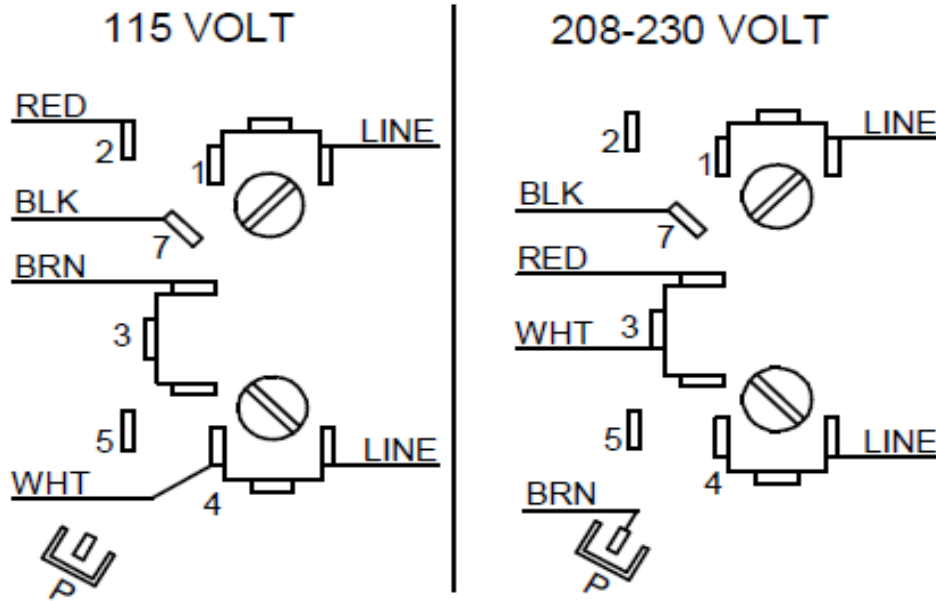

MOTOR IS CCW ROTATION LEAD END  
TO REVERSE ROTATION INTERCHANGE  
RED AND BLACK LEADS

DRAWING NO.	PAGE 1 of 1	REV.
4NXG3BG		0