

Please read through this owners manual carefully before using your new tool. Use your tool property and only for its intended use.



Electronic Depth Micrometer

Operational Manual

1. Functional elements

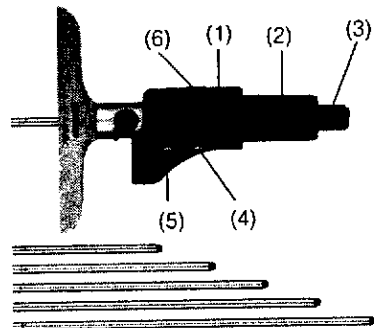

- (1): LCD display
- (2): Friction drive
- (3): Quick drive
- (4): ABS/INC...UNIT key
- (5): ON/OFF...SET key
- (6): Data output

2. Keys

ON/OFF...SET key: Power switch. Datum set.
ABS/INC...UNIT key: Absolute & relative measuring. Metric/Inch conversion.

3. LCD Display

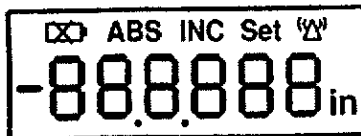

- 'ABS' : Absolute measuring mode.
- 'INC' : Relative measuring mode.
- 'SET' : Origin set.
- 'in' : Unit: inch, otherwise mm.
- : Low battery.
- : Data output is going.

4. Operation

Two ways of pressing the keys are used in the following illustrations:
(1) Press and release; (2) Press and hold (2 sec. or more).

4.1 ON/OFF...SET key:

Press and release: Power on/off.
Press and hold (2 sec. or more): Datum setting for absolute measurement; "Set" sign displayed on LCD.
Origin of metric is 0, 25, 50, 75 ... 275mm. Origin of inch is 0, 1", 2", 3" ... 11".
Sets datum automatically after battery reset.

4.2 ABS/INC...UNIT key:

Press and release: Absolute and relative measuring mode conversion; "INC" sign displayed on LCD in relative measuring mode. "ABS" sign displayed on LCD in absolute measuring mode.
Press and hold (2 sec. or more): Metric/Inch conversion; "in" sign displayed on LCD for inch, otherwise mm.

5. Power

- A silver oxide cell SR44 (5U085) is inserted into the back of the instrument with the positive pole outward. Replace the battery when the display data is dim or the sign is displayed in the upper left of the LCD.
- If not used for approximately five minutes, the power will auto-off. The micrometer will turn on by pressing "ON/OFF...SET" key or turning the spindle. Power off the micrometer by pressing "ON/OFF...SET" key to save the battery.

6. Specifications

Measuring force: 5 ~ 10N Power consumption: ≤ 20 μ A
Operating temperature: 0 ~ 40°C Storage temperature: -20 ~ 60°C

7. Data Output

1200 Baud, no parity, 7 data bits, 2 stop bits, no flow control.

8. Precautions

- Do not subject the instrument to blows or knocks. Do not drop it or apply excessive force.
- Do not disassemble the instrument.
- Do not press the keys with a pointed object.
- Do not use or store the instrument under direct sunlight, or in an excessively hot or cold area.
- Do not use the instrument near strong magnetic fields and high voltages.
- Use a soft cloth or a cotton swab that is dry to clean the instrument. Do not use organic solvent such as acetone or benzene. Alcohol may be used.
- Wipe the measuring faces of the instrument before using it.
- Remove the battery if the instrument is not used for a long period of time.

9. Troubleshooting

Failure	Causes	Repairing The Failure
Display "E 1" on LCD.	Data overflow.	Move spindle in reverse or press "ON/OFF...SET" key.
Display "E 3" on LCD.	1. Sensor overflow. 2. Something wrong with sensor.	1. Reset battery (remove for 3 minutes). 2. Return the micrometer for repair.
Measuring data is not correct.	1. Dirty measuring surfaces. 2. Preset data is not correct.	1. Clean measuring surfaces. 2. Inspect preset data and reset it.
No display on LCD.	1. Battery voltage under 1.45v. 2. Battery is not properly set.	1. Replace battery. 2. Reset battery (remove for 3 minutes).
Display confused or remains blank. 1. Display blurred. 2. The output data is wrong.	Battery voltage under 1.45v.	Replace battery. Replace battery.