

WESTWARD[®]

BUILT INDUSTRIAL TOUGH

20 GALLON PARTS WASHER OPERATING INSTRUCTION AND PARTS MANUAL

Model # 4KTV6



QUALITY GUARANTEE:

Should a Westward product fail to perform satisfactorily due to defect or poor workmanship within one year of purchase, return it to your place of purchase and it will be replaced or repaired free of charge. Incidental or consequential damages are excluded from this warranty.

READ ALL INSTRUCTIONS BEFORE OPERATING

SAVE THESE INSTRUCTIONS

Thank you for purchasing your Westward 4KTV6 Parts Washer. Before attempting to operate your new Parts Washer please read these instructions thoroughly. You will need these instructions for the safety warnings, precautions, assembly, operation, maintenance procedures, parts list and diagrams. Keep your invoice with these instructions. Write the invoice number on the inside of the front cover. Keep the instructions and invoice in a safe, dry place for future reference.

WARNING: The warnings, cautions and instructions discussed in this instruction manual cannot cover all possible conditions or situations that could occur. It must be understood by the operator that common sense and caution are factors which cannot be built into this product, but must be supplied by the operator.

TABLE OF CONTENTS

Description	Page#
Specifications	1
Safety Rules	1
Getting Started	1
Power Requirements	1-2
Extension Cords	2
Assembly	2
Operation	2
Trouble Shooting	2
Parts List and Diagram	3

SPECIFICATIONS

Tank Size(LxWxH)	.30" x 20 1/2" x 10 1/2"
Assembled Dims(LxWxH)	.31" x 21" x 34 1/2"
Weight	.52 lbs.
Maximum Capacity	.20 gallons
Working Capacity	.12 gallons

SAFETY RULES

1. Know your tool. Read this manual carefully. Learn the tool's applications and limitations, as well as specific potential hazards peculiar to it.
2. Ground all tools. If the tool is equipped with three-pin plug, it should be plugged into a three-pin electrical socket. Never remove the ground pin. Failure to properly ground unit could result in severe electrical shock and / or death.
3. Do not abuse cord. Never use the cord to carry tools or pull the plug from an outlet. Keep cord away from heat, sharp edges or moving parts. Replace damaged cords immediately. Damaged cords increase the risk of electric shock.
4. Keep work area clean and well lit. Cluttered or dark work areas invite accidents.
5. Keep children away. All children should be kept away from the work area. Never let a child handle a tool without strict

adult supervision.

6. Do not operate this tool if under the influence of alcohol or drugs. Read warning labels on prescriptions to determine if your judgment or reflexes are impaired while taking drugs. If there is any doubt, do not attempt to operate.
7. Use safety equipment. Eye protection should be worn at all times when operating this tool. Use ANSI approved safety glasses. Everyday eyeglasses only have impact resistant lenses. They are NOT safety glasses. Dust mask, non-skid safety shoes, hard hat, or hearing protection should be used in appropriate conditions.
8. Wear proper apparel. Loose clothing, gloves, neckties, rings, bracelets, or other jewelry may present a potential hazard when operating this tool. Please keep all apparel clear of the tool.
9. Don't overreach. Keep proper footing and balance at all times when operating this product.
10. Always disconnect the tool from the power source before making any adjustments, storing, servicing, or changing accessories. Such preventative safety measures reduce the risk of starting the tool accidentally.
11. Do not use the tool if the switch does not turn it on and off. Any tool that cannot be controlled with the switch is dangerous and must be repaired.
12. Check for damage. Check your tool regularly. If part of the tool is damaged it should be carefully inspected to make sure that it can perform its intended function correctly. If in doubt, the part should be repaired. Refer all servicing to a qualified technician. Consult your dealer for advice.
13. Keep away from flammables. Do not attempt to operate this tool near flammable materials or combustibles. Failure to comply may cause serious injury or death.
14. Store idle tools out of the reach of children and untrained persons. Tools may be dangerous in the hands of untrained users.

GETTING STARTED

Unpack your Westward Parts Washer. After unpacking the unit, inspect carefully for any damage that may have occurred during transit. Check for any loose, missing or damaged parts.

Your Westward Parts Washer includes:

Bolts	.24
Spring Washers	.24
Lock Nuts	.24
Legs	.4
Lower Shelf	.1
Middle Shelf	.1
Pump Assembly	.1
Basket	.1

POWER SOURCE CONNECTION POWER REQUIREMENTS

This product is designed to operate on a properly grounded 120 volt, 60Hz, single-phase alternating current (ac) power source fused with a 20 amp time delayed fuse or circuit breaker. It is recommended that a qualified electrician verify the **ACTUAL VOLTAGE** at the receptacle into which the product will be plugged and confirm that the receptacle is properly fused and grounded.

DO NOT OPERATE THIS PRODUCT if the ACTUAL power source voltage is less than 105 volts ac or greater than 132 volts

ac. Contact a qualified electrician if this problem exists. Improper performance and/or damage to the product will result if operated on inadequate or excessive power.

CONNECT TO POWER SOURCE



High voltage danger from power source!

Consult a qualified electrician for proper installation of receptacle at the power source.

This product must be grounded while in use to protect the operator from electrical shock. If you are not sure if your outlet is properly grounded, have it checked by a qualified electrician. Do not cut off the grounding prong or alter the plug in any way and do not use any adapters between the product's power cord and the power source receptacle. Make sure the POWER switch is OFF then connect the power cord to a properly grounded 120 Vac, 60 Hz, single phase, 20 amp power source.

EXTENSION CORDS

For optimum performance, an extension cord should not be used unless absolutely necessary. If necessary, care must be taken in selecting an extension cord appropriate for use with your specific product.

Select a properly grounded extension cord that will mate directly with the power source receptacle and the power cord without the use of adapters. Make certain that the extension is properly wired and in good electrical condition.

Extension cords must be a minimum #12 gauge cord. Do not use an extension cord over 25 ft. in length.

WHEN INSTALLING YOUR PARTS

WASHER

1. Assemble it according to the instructions given below.
2. Sit it on a firm, flat, level surface in a well ventilated area and away from any open flames.
3. Fill only with a non-flammable water-based degreaser or cleaning agent, such as Simple Green to just below the level of the parts shelf (approximately 12 gallons).
4. Follow the degreaser manufacturer's instructions carefully.
5. Do not fill with flammable solvents such as kerosene, gasoline, etc.

WHEN USING YOUR PARTS WASHER

1. Wear suitable protective clothing, gloves and goggles.
2. Clean off any accidental splashes of degreaser on skin immediately, following the degreaser manufacturer's instructions carefully. Seek medical attention if necessary.
3. Keep work area tidy and mop up any accidental spills of degreaser.

WHEN NOT IN USE

1. Switch off pump, close the lid and disconnect from the electrical supply.
2. Disconnect from the electrical supply before carrying out any maintenance or cleaning on the parts washer.

 **WARNING** The pump of your parts washer may be damaged if you use solvents like perchloroethylene or trichloroethylene.

ELECTRICAL CONNECTIONS

Plug into a standard 120 volt grounded plug.

 **WARNING** This appliance must be grounded.

ASSEMBLY INSTRUCTIONS

1. Remove machine from carton and inspect for any visual damage.
2. Remove parts inside the machine.
3. Lay clean and hard cardboard on the floor and lay machine on its lid. (Make sure you hold cover closed when laying machine on its lid.)
4. Mount four legs on brackets with M6x12 phillips head screws and M6 nuts. NOTE: DO NOT TIGHTEN.
5. Place lower shelf between legs with flat surface up and attach to legs with M6x12 phillips head screws and M6 nuts.
6. With legs pressed tight against lower shelf, tighten all screws to lower shelf.
7. Tighten all the screws installed in Step 4.
8. Stand machine up, being careful to hold lid closed.
9. Put work shelf and basket into the machine.
10. Remove Styrofoam packing from pump (see pump label for instructions) and mount pump assembly into slot on the side of the machine. Push down firmly on pump so that it seats itself onto side wall of tub. Place filter screen in position.
11. Thread the flexible nozzle into the elbow attachment on pump housing and firmly screw into place.
12. Plug machine into standard 120 volt 60 Hz grounded outlet and fill with proper amount of fluid.
13. Turn switch on. Fluid should be flowing from the flexible nozzle.

OPERATION

Always wear protective clothing, gloves and goggles when using your Parts Washer.

1. Open the parts washer lid and place parts to be washed on the washboard.
2. Position the flexible nozzle so that it is directly above your parts.
3. Turn the power switch to the ON position.
4. Clean parts as needed.
5. Turn power switch to the OFF position.
6. Place parts on drying shelf until completely dry.
7. Empty drain tank, as needed, by sliding out of drying shelf brackets.



Clean off any accidental splashes of degreaser on skin immediately, following the degreaser manufacturer's instructions carefully. Seek medical attention if necessary.

MAINTENANCE

1. The lid incorporates a fusible link to close the lid in the event of a fire. This link is non-resetting and must be replaced once it has been triggered.
2. Clean the pump filter regularly by sliding it away from the pump housing and rinsing in clean degreaser.
3. Do not allow the level of liquid in the parts washer to fall below the pump inlet, as damage to the pump can result.
4. Change degreaser as needed. Tank can be drained by removing the drain plug located on bottom of tank.

TROUBLE SHOOTING

The only trouble you should ever experience with your Parts Washer is reduced volume flow or no flow of cleaning liquid from the flex hose nozzle. The probable cause is:

1. Foreign matter in the flex hose.
2. Low fluid level (not reaching the pump inlet).
3. Blocked/dirty filter.
4. Air in the pump. You can turn on and turn off the parts washer for several times or knock on the pump housing for several times to fix this problem.

PARTS LIST AND DIAGRAM

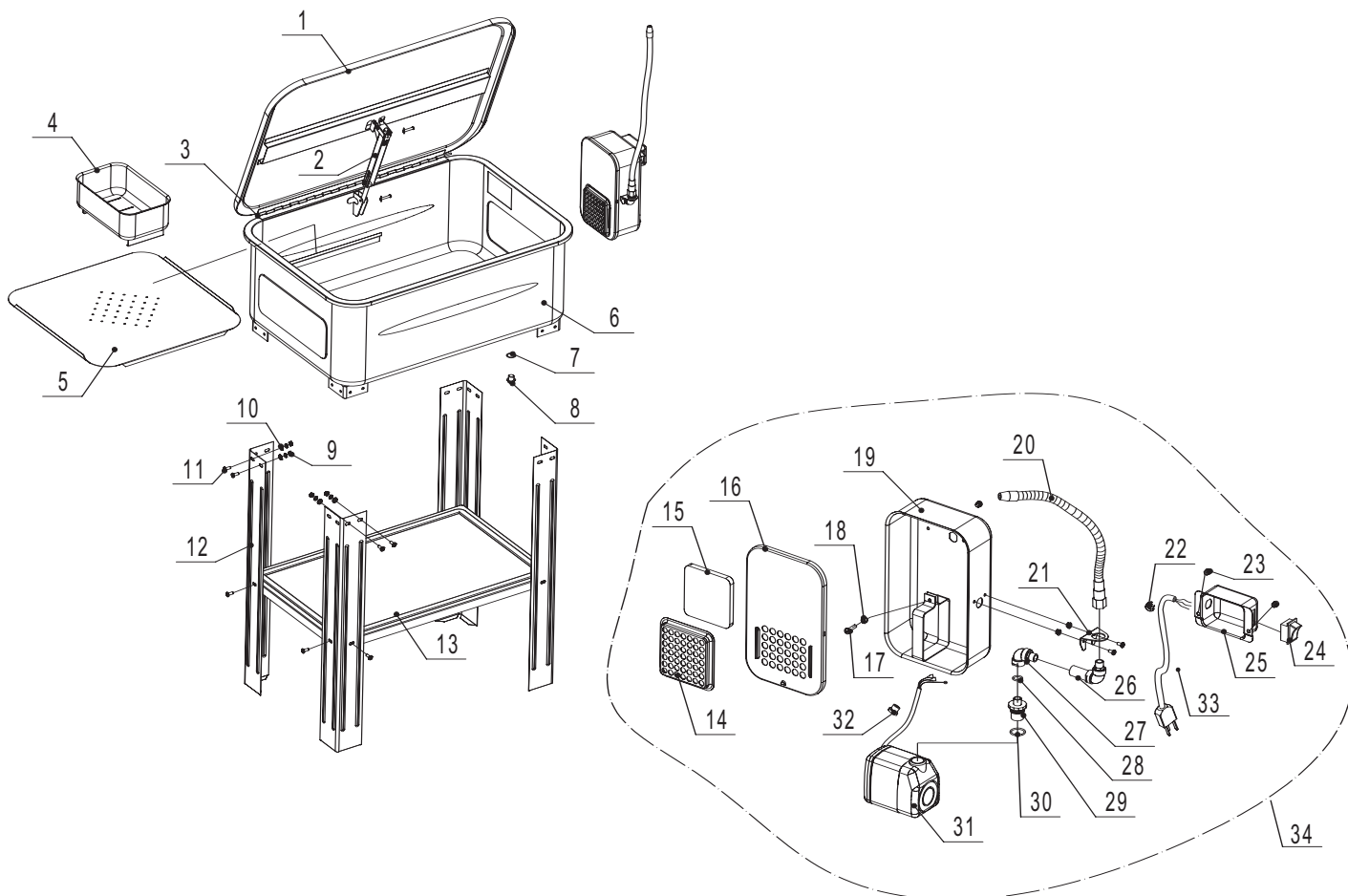

Part No.	Description	Grainger No.	Qty.	Part No.	Description	Grainger No.	Qty.
4KTV6-01	Cover		1	4KTV6-18	M5 Nut		1
4KTV6-02	Fusible Link	TT4KTV601G	1	4KTV6-19	Pump Housing		1
4KTV6-03	Shaft		1	4KTV6-20	Flexible Pipe	TT4KTV606G	1
4KTV6-04	Work Basket		1	4KTV6-21	Elbow Seat		1
4KTV6-05	Work Shelf		1	4KTV6-22	Strain Relief		1
4KTV6-06	Body		1	4KTV6-23	M4x8 Screw (with Nut, Spring Washer and Flat Washer)		5
4KTV6-07	O-ring		1	4KTV6-24	Switch	TT4KTV903G	1
4KTV6-08	Plug		1	4KTV6-25	Switch Box		1
4KTV6-09	M6 Nut		24	4KTV6-26	Elbow-1		1
4KTV6-10	Spring Washer		24	4KTV6-27	Elbow-2		1
4KTV6-11	M6x12 Screw		24	4KTV6-28	O-ring		1
4KTV6-12	Leg		4	4KTV6-29	Connector		1
4KTV6-13	Shelf		1	4KTV6-30	O-ring		1
4KTV6-14	Filter Cover		1	4KTV6-31	Pump	TT4KTV902G	1
4KTV6-15	Filter	TT4KTV604G	1	4KTV6-32	Strain Relief		1
4KTV6-16	Pump Housing Cover		1	4KTV6-33	Cable & Plug		1
4KTV6-17	M5x20 Screw		1	4KTV6-34	Pump Assembly	TT4KTV603G	1