

**M-10838 3**

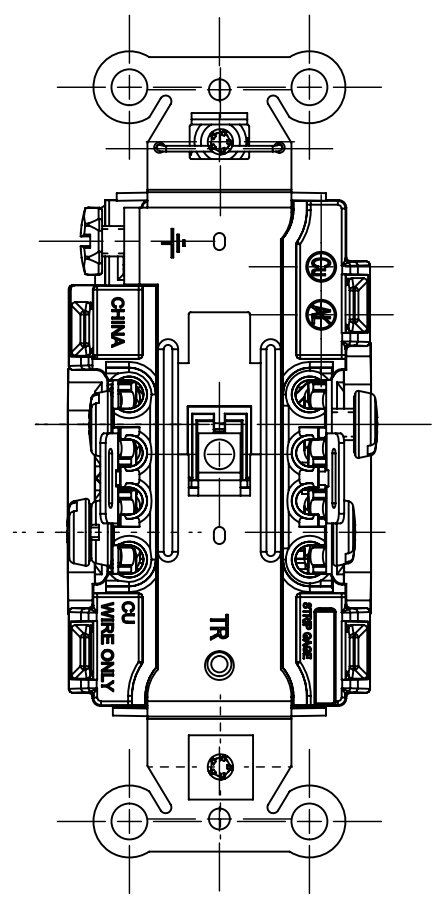
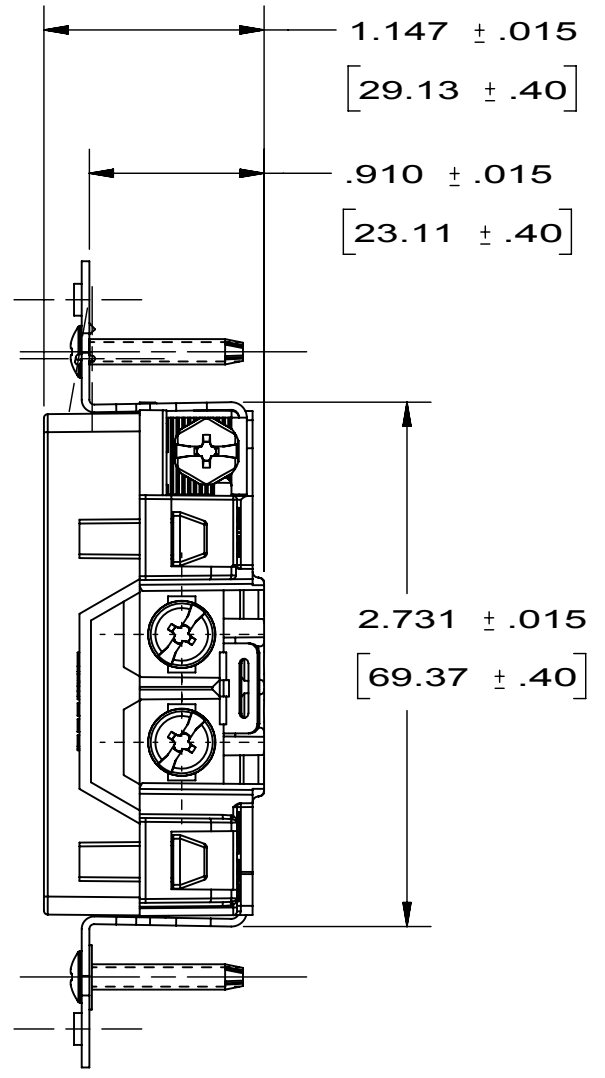
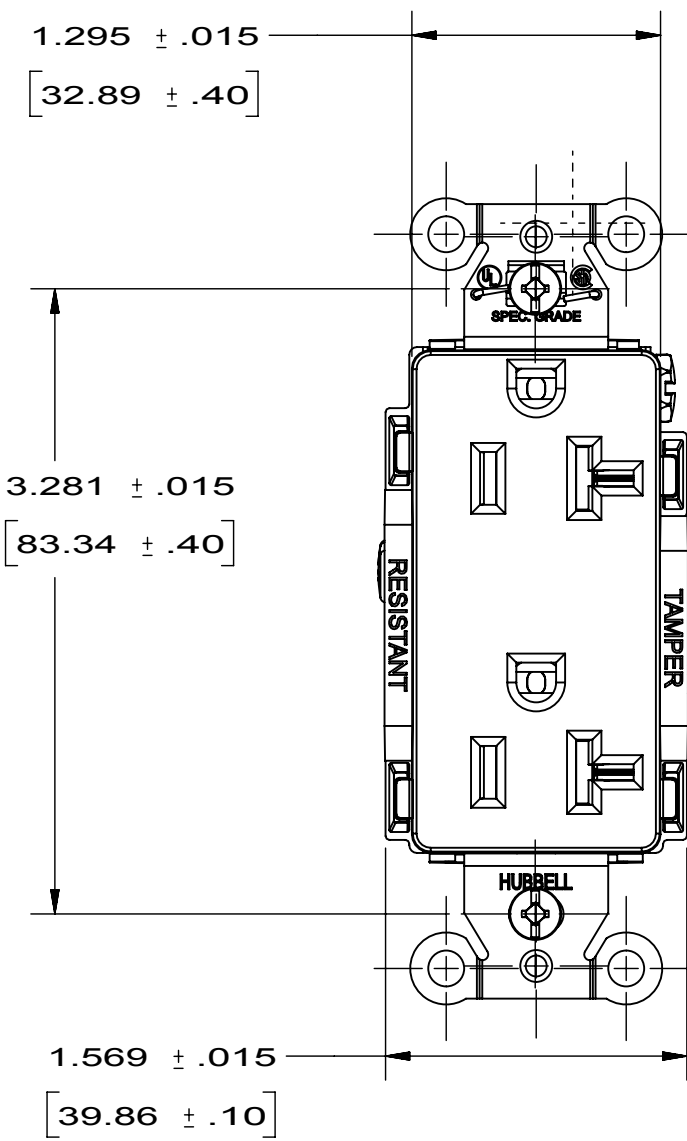

- NOTES:**  
 1) DIMENSIONS ARE IN INCHES [MM].  
 2) ALL DEVICES UL LISTED AND CSA CERTIFIED.  
 3) TERMINALS ACCOMMODATE #14-#10 AWG COPPER WIRE ONLY.

**CATALOG NUMBERS**

BROWN	IVORY	GRAY	WHITE	BLACK	ALMOND	BLUE	LIGHT ALMOND	RED	ORANGE	OFFICE WHITE	GREEN
DR20TR	DR20ITR	DR20GRYTR	DR20WHITR	DR20BLKTR	DR20ALTR	DR20BLTR	DR20LATR	DR20RTR	-----	-----	DR20GNTR

**LIST OF PARTS**

DESCRIPTION	MATERIAL	FINISH
TOP	NYLON 6/6	SPI A-3
BASE	NYLON 6/6	SPI A-3
LINE CONTACTS	BRASS	
GROUND CONTACTS	BRASS	
CONTACT SCREW (NEU)	STEEL	NI PLT
CONTACT SCREW (HOT)	STEEL	
BRIDGE	04 GALV STL	
GROUND SCREW	STEEL	GREEN
STAPLE	S.S.	
WASHER	PVC FILM	BLACK
MOUNTING SCREW	STEEL	ZINC PLT

SYM	REVISIONS	APP	DATE
3	ADDED CATALOG No. DR20GNTR (GREEN) TO TABLE PER DCN 23477 RM	DJP	12/18/17
2	ADDED CAT. NOS. DR20BLTR & DR20RTR TO TABLE. PER DCN 19208 DDL	DJP	11/16/12
1	RELEASED PER DCN# 14341 WRV		01/07/08

THE DESIGN AND DIMENSIONS OF THE PRODUCT SHOWN ON THIS DRAWING ARE SUBJECT TO CHANGE WITHOUT NOTICE

**TITLE** HUBBELL  
 20A 125V, 2P 3W  
 TAMPER RESISTANT  
 STYLELINE DUPLEX RECEPT.  
 BACK & SIDE WIRE

TOLERANCES UNLESS OTHERWISE SPECIFIED  .XX = ± .01 .XXX = ± .005 ANGLES = ± 2°	WIRING DEVICE-KELLEMS HUBBELL INCORPORATED SHELTON, CT	
	DR. BY WRV	APP. BY
	TR. BY	SCALE 1:1
	CHK. BY	DATE 3/07

DIMENSION SHEET FOR CAT. NO.

REPAIRABLE

NON-REPAIRABLE

**B**

**M-10838**

**3**