

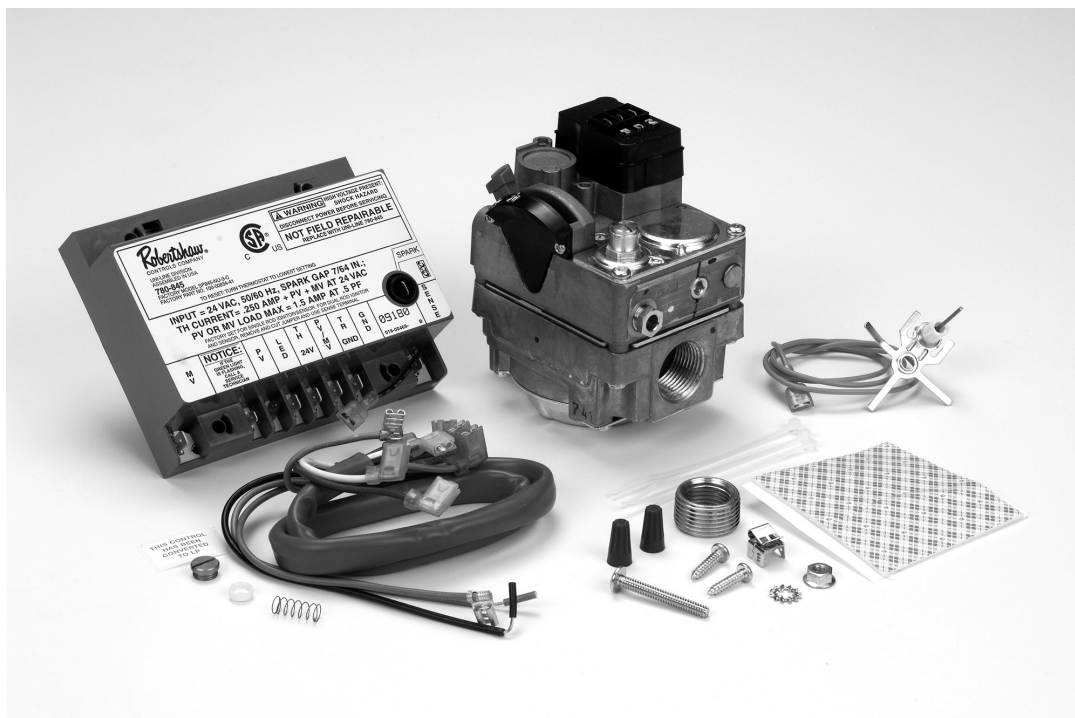

INSTALLATION DATA

712 SERIES PILOT IGNITION SYSTEMS (FLAME RECTIFICATION)

LOCKOUT MODEL 712-005 • 712-006 • 712-008 • 712-009
NON-LOCKOUT MODELS 712-005 • 712-016 • 712-017 • 712-019 •
712-022



**CSA DESIGN CERTIFIED TO APPLICABLE A.N.S.I. STANDARD
Z21.71-1993 FOR FIELD INSTALLATION**



ORDERING DATA

ORDER NUMBER	GAS VALVE CONNECTION	IGNITION UNIT	MODEL - GAS DESCRIPTION
Lockout Models* - Lockout Timing Is 90 Seconds			
712-005	722-079 1/2" x 1/2"	780-845 (Lockout)	Universal Model- Gas valve has natural gas pressure regulator set at 3.5" WC. A separate LP gas pressure regulator set at 11.0" WC is also included. 170,000 BTU Max. Nat. Gas/272,000 BTU Max. LP gas.
712-006	700-056 3/4" x 3/4"	780-845 (Lockout)	Universal Model - Gas valve has natural gas pressure regulator set at 3.5" WC. A separate LP gas pressure regulator set at 11.0" WC is also included. 350,000 BTU Max. Nat. Gas/560,000 BTU Max. LP gas.
712-008	720-070 1/2" x 3/4"	780-845 (Lockout)	Universal Model - Gas valve has natural gas pressure regulator set at 3.5" WC. A separate LP gas pressure regulator set at 11.0" WC is also included. 200,000 BTU Max. Nat. Gas/320,000 BTU Max. LP gas.
712-009	700-059 1" x 1"	780-845 (Lockout)	Universal Model - Gas valve has natural gas pressure regulator set at 4.0" WC. A separate LP gas pressure regulator set at 11.0" WC is also included. 720,000 BTU Max. Nat. Gas/1,152,000 BTU Max. LP gas.
Non-lockout Models - Caution: Do Not Use On LP Gas Applications			
712-015	720-072 1/2" x 3/4"	780-715 (Non-lockout)	Natural Gas Only - Non-lockout. Valve has 1/2" side outlets. Pressure regulator is factory-set at 3.5" WC 200,000 BTU Max.
712-016	700-056 3/4" x 3/4"	780-715 (Non-lockout)	Natural Gas Only - Non-lockout. Pressure regulator is factory-set at 3.5" WC 350,000 BTU Max.
712-017	720-070 1/2" x 3/4"	780-715 (Non-lockout)	Natural Gas Only - Non-lockout. Pressure regulator is factory-set at 3.5" WC 200,000 BTU Max.
712-019	700-059 1" x 1"	780-715 (Non-lockout)	Natural Gas Only - Non-lockout. Pressure regulator is factory-set at 4.0" WC 720,000 BTU Max.
712-022	722-079 1/2" x 1/2"	780-715 (Non-lockout)	Natural Gas Only - Non-lockout. Pressure regulator is factory-set at 3.5" WC 170,000 BTU Max.
*The 780-845 lockout ignition control used in the 712 series Kits, provides 90 seconds of spark followed by a six minute time delay (purge) period between ignition attempts. After three tries, if no pilot flame is sensed, 780-845 goes into a 1 hour lockout period. At the end of the 1-hour lockout period, if the demand for heat is still present, unit repeats the three tries for ignition.			

SPECIFICATIONS

GAS VALVES

The Robertshaw® gas valves used in the 712 Series kits are CSA design certified to applicable ANSI standards. Gas valves that are included in the 712 Series pilot ignition systems have a built-in, slow-opening feature for soft ignition characteristics at the main burner. Does not include the 712-005 and 712-022 kits.

7000 BDER-S7A (712-006 AND -016 KITS)		
Electrical	24 volt, 60 Hz	
Ambient rating	- 40°F to 175°F (- 40°C to 80°C)	
Capacity (maximum regulation)		
1/2" x 3/4" straight-through	300,000 BTU	
3/4" x 3/4" straight-through	350,000 BTU	
Pressure regulator (factory-set)	3.5" WC Natural Gas (Adjustable 3" to 7" WC)	

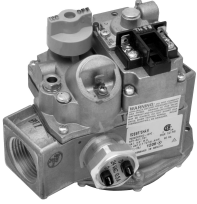
7000 DERHC-S7C (712-009 AND -019 KITS)		
Electrical	24 volt, 60 Hz	
Ambient rating	- 40°F to 175°F (- 40°C to 80°C)	
Capacity (maximum regulation)		
1" x 1"	720,000 BTU	
3/4" x 1" using reducer bushings (included)	530,000 BTU	
3/4" x 3/4" using reducer bushings (included)	450,000 BTU	
Pressure regulator (factory-set)	4.0" WC Natural Gas (Adjustable 3" to 7" WC)	

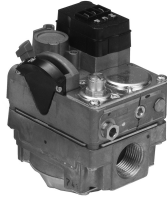
7200 IPER-S7C (712-008, -015 AND -017 KITS)		
Electrical	24 volt, 60 Hz	
Ambient rating	- 40°F to 175°F (- 40°C to 80°C)	
Capacity (maximum regulation)		
1/2" x 3/4" straight-through	200,000 BTU	
Pressure regulator (factory-set)	3.5" WC Natural Gas (Adjustable 3" to 7" WC) 11.0" WC LP Gas (Adjustable 8" to 12" WC)	

2000 IPER-HC (712-005 AND -022 KITS)		
Electrical	24 volt, 60 Hz	
Ambient rating	- 40°F to 175°F (- 40°C to 80°C)	
Capacity (maximum regulation)		
1/2" x 1/2" straight-through	170,000 BTU	
Pressure regulator (factory-set)	3.5" WC Natural Gas	
Input voltage	24 VAC 50/60 Hz	
Transformer	24 VAC / 20 VA minimum	

IGNITION CONTROL UNITS

Robertshaw ignition control units used in the 712 Series kits are CSA design certified to applicable ANSI standards.

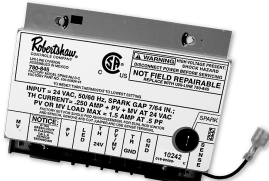
780-715 (712-015, -016, -017, -019 AND -022 KITS) 780-845 (712-005, -006, -008, AND -009 KITS)		
Safety lockout timing (780-845)	See footnote*	<div style="display: flex; flex-direction: column; align-items: center;"> <div style="text-align: center;">780-715</div>  <div style="text-align: center;">780-845</div>  </div>
Spark rate	3 to 4 sparks per second	
Relay contact ratings		
Pilot valve	1 amp at .5 PF	
Main valve	1 amp at .5 PF	
Combined load	1.5 at .4 PF	
Flame sense current	.7 μ A DC @ 25°C / 24 VAC	
Maximum total current load	1.5 amp	
Flame failure re-ignition time	.8 seconds maximum	
Thermostat anticipator setting	.7 amp	
Ambient rating	- 40°F to 175°F (- 40°C to 80°C)	
Relative humidity	95% non-condensing at 104°F	

*The 780-845 lockout ignition control used in the 712 series kits, provides 90 seconds of spark followed by a six minute time delay (purge) period between ignition attempts. After three tries, if no pilot flame is sensed, the 780-845 goes into a 1 hour lockout period. At the end of the 1 hour lockout period, if the demand for heat is still present, the unit repeats the three tries for ignition.

PRE-INSTALLATION INSTRUCTIONS



CAUTION

The 712 Series Pilot Ignition System must be installed by a qualified installing agency with due regard for safety. Improper installation could result in a hazardous condition.

Installation must comply with all local codes. In the absence of local codes, the latest edition of the National Fuel Gas Code, ANSI Z223, and the National Electrical Code ANSI/NFPA No. 70 must be used.

The 712 Series Pilot Ignition System has been designed for an easy installation, however, for the system to function properly and to give trouble-free service. The installer must follow these installation instructions word for word and without taking any short cuts. Take your time installing this system, make sure it is working properly before leaving the job site. Failure to do so could result in a system failure.

This Pilot Ignition System must be used only on appliances equipped with an atmospheric gas burner. Use on direct-vent type appliances and power burners is prohibited.

Be sure you have the correct Pilot Ignition System for the type of gas used on the application, LP or natural. Using an incorrect system could result in a hazardous condition.

LP Gas Application

Use the lockout models only for inside or poorly ventilated applications.

Natural Gas Application

Use either model type: Lockout models 712-005, 712-006, 712-008, 712-009 or non-lockout models 712-015, 712-016, 712-017, 712-019, 712-022.

Ambient Temperature Limitations

Be sure the installation of the Pilot Ignition System will not exceed its rated ambient temperature range: -40°F to 175°F (-40°C to 80°C). This is extremely important when the application is being made to a rooftop unit in cold climates.

SAFETY INSPECTION PROCEDURES

The CSA pre-installation safety procedures listed below are intended as a guide to aid in determining that an appliance is properly installed and is in a safe condition for continued use.

This procedure is predicated on central furnace and boiler installations equipped with an atmospheric gas burner(s) and not at the direct-vent type. It should be recognized that generalized test procedures cannot anticipate all situations. Accordingly, in some cases, deviation from this procedure may be necessary to determine safe operation of the equipment.

- A. This procedure should be performed prior to any attempt at modification of the appliance or the installation.

- B. If it is determined there is a condition which could result in unsafe operation, the appliance should be shut off and the owner advised of the unsafe condition.

The following steps should be followed in making the safety inspection:

1. Conduct a gas leakage test of the appliance piping and control system downstream of the shutoff valve in the supply line to the appliance.
2. Visually inspect the venting system for proper size and horizontal pitch and determine that there is no blockage or restrictions, leakage or corrosion or other deficiencies which could cause an unsafe condition.
3. All gas equipment must have an accessible manual gas shutoff valve installed in the gas supply line upstream of the appliance. If a manual, accessible gas valve is not in the gas supply line within six feet of the appliance, one shall be installed. Shut off all gas to the appliance and shut off any other fuel burning appliance in the same room. Use the shutoff valve in the supply line to each appliance.
4. Inspect burners and crossovers for blockage and corrosion. Inspect all wiring for damage, correct any defects found.
5. Applicable only to warm air heating appliances. Inspect heat exchangers for cracks, openings or excessive corrosion.
6. Applicable only to boilers. Inspect for evidence of water or combustion product leaks.
7. As far as is practical, close all building doors and windows and all doors between the space in which the appliance is located and other spaces of the building. Turn on clothes dryers. Turn on any exhaust fans, such as range hoods and bathroom exhausts, so they will operate at maximum speed. Do not operate a summer exhaust fan. Close fireplace dampers. If after completing steps 7 through 12, it is believed sufficient combustion air is not available, refer to 1.3.4 National Fuel Gas Code (2223.1) for guidance.
8. Place in operation the appliance being inspected. Follow the lighting instructions. Adjust thermostat so appliance will operate continuously.
9.
 - A. Determine that the pilot is burning properly and that main burner ignition is satisfactory by interrupting and re-establishing the electrical supply to the appliance in any convenient manner.
 - B. With a manometer, determine manifold pressure in order to match input after the new control is installed.
10.
 - A. Visually determine that main burner gas is burning properly; i.e., no floating, lifting or flashback. Adjust the primary air shutter(s) as required.
 - B. If appliance is equipped with high and low flame control or flame modulation, check for proper main burner operation at low flame.

11. Test for spillage at the draft hood relief opening after 5 minutes of main burner operations. Use a draft gauge, the flame of a match or candle, or smoke from a cigarette, cigar or pipe.
12. Return doors, windows, exhaust fans, fireplace dampers and all other fuel-burning appliances to their previous conditions of use.
13. Applicable only to warm air heating appliances: Check both limit control and fan control for proper operation. Limit control operation can be checked by temporarily disconnecting the electrical supply to the blower motor and determining that the limit control acts to shut off the main burner gas.
14. Applicable only to boilers:
 - A. Determine that the circulating water pumps are in operating condition.
 - B. Test low water cutoffs, automatic feed water controls, pressure and temperature limit controls and relief valves in accordance with the manufacturer's recommendations and instructions to determine that they are in good operating condition.

TESTING THE EXISTING SYSTEM

Before starting installation, a safety inspection of the appliance must be performed. Once safety inspection has been completed, continue as follows:

1. Check that the existing pilot is a thermocouple type used with an electromagnetic safety. Some manufacturers use bimetal type pilots wired to the valve operator. If the application has a bimetal pilot, it must be replaced with a thermocouple-type pilot.
2. The Pilot Ignition System is designed to be adapted to the existing pilot.

NOTE: Robertshaw and CSA recommend that the original pilot be used and remain in its original position.

3. Locate the rating plate on the appliance and determine the input rating (BTU per hour). The input rating (capacity) for the Pilot Ignition System must be equal to or greater than the input rating of the appliance. See SPECIFICATIONS for Pilot Ignition System Capacity or Input Rating.
4. Do not install in a wet area without protection for the components.
5. To ensure proper operation, the appliance transformer must be rated at:
 - 24 volts/20VA (minimum)
 - 24 volts/40VA (minimum) - When used in conjunction with an Automatic Vent Damper.

The output of the appliances transformer can be determined by the following steps:

- A. Compute the total current draw by adding the current draw of the Pilot Ignition System (.7 amp) to the current draw of any associated valving, relays, dampers or other devices operated by the transformer.

- B. Multiply the total current draw computed in "A" above by 24 volts. This will give the total VA (Voltage-Amperage) required.
 - C. The total VA (Volt-Amperage) required should be equal to or less than the VA rating of the appliance transformer.
 - D. If the total VA (Volt-Amperage) required is greater than the VA rating of the transformer, replace it with a Class 2 transformer of adequate rating.
6. Cycle the furnace ON to ensure it is working properly. If the transformer, limit switch or thermostat are faulty, the ignition system will not function. Check the performance characteristics of the pilot flame. The flame should be impinging on the thermocouple and be blue in color. If not, you will need to adjust the pilot and/or clean the orifice and pilot tube. Be sure that inlet gas pressure is adequate.
 7. Turn OFF all electrical power and gas to the appliance before attempting to disconnect the wiring and gas valve. To shut off the gas, use the shutoff valve in the supply line to the appliance. If a manual gas valve is not in the gas supply line within 6 feet of the appliance, and in an accessible location, one shall be installed. **DO NOT USE THE GAS COCK ON THE GAS VALVE.**
 8. Remove the thermocouple and pilot tubing from the existing gas valve.
 9. You may encounter two methods of gas valve wiring. Determine from the diagrams below which one you have. Disconnect the electrical leads from the gas valve.

A. **TWO TERMINAL CONNECTION**

Disconnect the two wires connecting the gas valve.

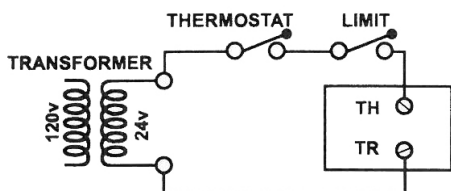

B. **THREE TERMINAL CONNECTION**

If three terminals on the gas valve are used, two wires may be connected to a common terminal. Remove these two wires first and wire-nut them together. Three wire nuts are provided in the kit. Now, remove the other two wires from the existing gas valve.

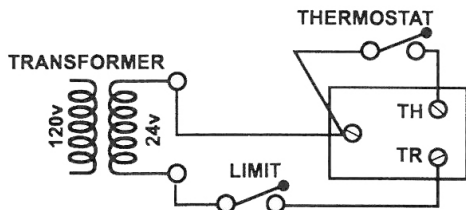

10. Remove gas valve and/or controls containing the main valve, regulator and safety functions from the manifold. These functions are built into the new replacement gas valve.

11. Remove the pilot assembly and disconnect the thermocouple from the pilot. The pilot will be reinstalled back into its original mounting position.
12. Inspect the inside of the pilot tubing. It should be free of any scale or other foreign matter. Clean or replace if necessary. We also recommend that the pilot orifice be cleaned to ensure optimum system operation.

INSTALLATION INSTRUCTIONS

IGNITOR/SENSOR ASSEMBLY

NOTE: On some pilot applications a special adaptor kit is required. These adaptor kits are shown on page 8. Order these pilot adaptor kits separately if needed.

1. Assemble the combination ignitor/sensor assembly by sliding the mounting bolt through the mounting bracket as shown in Figure 1.

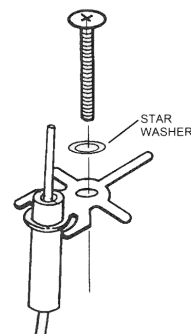

Figure 1

2. The ignitor/sensor assembly is ready to be attached to the furnace pilot. Slide the mounting bolt with the ignitor/sensor bracket down through the thermocouple opening of the pilot frame as shown in Figure 2. Install the retainer nut onto the mounting bolt and tighten finger tight.

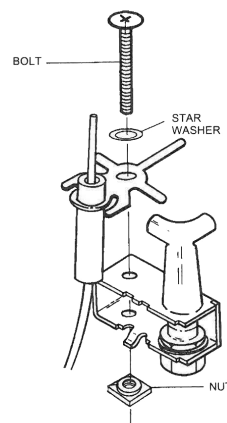

Figure 2

3. The ignitor/sensor can now be positioned for proper sparking and sensing. To obtain the best ignition characteristics:
 - The ignitor/sensor tip should be located on a horizontal plane with the top of the pilot gas exit port.
 - The tip should be located 1/8" (recommended spark gap) from the edge of the pilot hood.

- Be sure that sparking will occur in the path of the gas flow.
- Excess "wire or rod" should be cut off.
- Tighten the mounting bolt firmly so that the bracket assembly will not move or change position once the pilot is installed. See Figure 3.

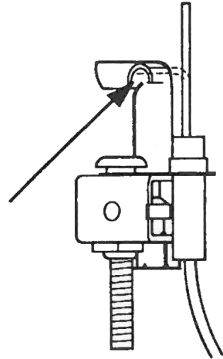

Figure 3

4. Bend the tabs to the ignitor/sensor mounting bracket down and around the pilot bracket frame. Using a pair of pliers, crimp the tabs so they grip the pilot bracket. This will hold the electrode assembly firmly in place as shown in Figure 4.

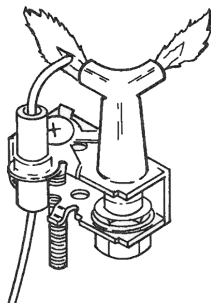

Figure 4

5. When selecting the ignitor/sensor tip location, remember the spark will jump the narrowest gap available to the nearest ground metal. Ensure that this gap is always at the point you select and not to the main burner, furnace chassis, burner manifold, or a part of the pilot hood where there is no flow, see Figure 5. The tip must be in the pilot flame for the ignitor/sensor to function properly.

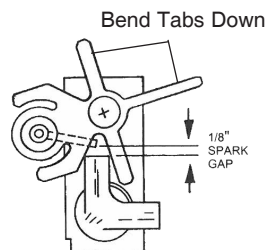

Figure 5

6. After crimping the ignitor/sensor mounting bracket tabs and selecting the point for the ignitor/sensor tip to spark to:
 - A. Measure the distance from this point to the ignitor/sensor rod Figure 6.

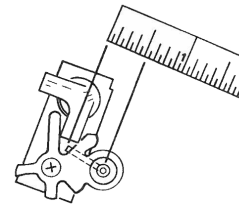
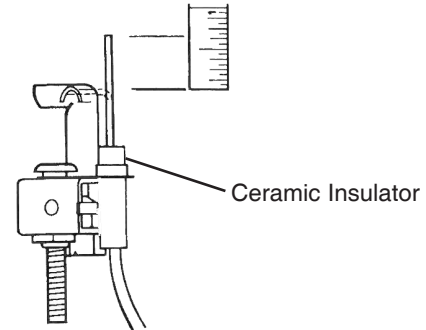



Figure 6

- B. Measure down the ignitor/sensor rod this distance plus 1/16" to allow for bend radius Figure 7. DO NOT BEND YET.





CAUTION

Always hold the ignitor/sensor rod between the ceramic and the bend you are making. This will prevent damaging the ceramic insulator. Pilot flame must not contact the ceramic portion of the ignitor/sensor assembly.

Figure 7

7. Holding pliers firmly on the ignitor/sensor rod at the distance measured, use finger pressure on the ignitor/sensor rod tip to slowly bend it towards pilot hood, Figure 8. If tip is too long, cut off excess.

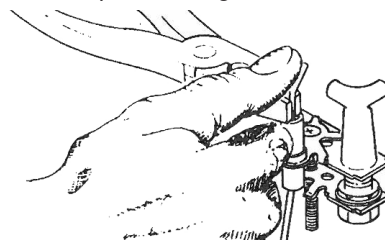

Figure 8

NOTE: Ignitor/sensor tip must be in pilot flame for the Ignition Control Unit to function properly.

8. Reinstall pilot assembly back into its original mounting position.

NOTE: Pilot is not to be relocated or altered. If replacing the pilot becomes necessary due to wear or damage, an exact replacement must be used.

SPECIAL PILOT ADAPTOR KITS

These special pilot adaptor kits are NOT included in the 712 kits. They must be ordered separately.

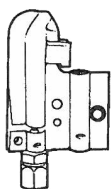

MAGIC CHEF, GAFFERS & SATTLER PILOT ADAPTOR KIT

Includes all the necessary parts to adapt the Magic Chef, Gaffers & Sattler sheet metal pilot to the 712 Series flame rectification pilot system.

ORDER 1751-712

INSTALLING THE GAS VALVE

- Installation and servicing of gas appliances and ignition systems must only be performed by qualified personnel.
 - Turn off gas and electricity before starting installation or service.
 - When replacing an LP control or a natural gas control, the new control must have the same regulator setting as the old control, or as specified on the appliance rating plate.
 - To install or remove the control, use the inlet boss as a gripping location to prevent unwanted rotation. Do not grip body with pipe wrench or vise.
 - Make sure gas piping is pressure tested before control is connected. High pressure can damage the control causing a hazardous condition.
 - Make sure piping is clean and free from burrs. Apply a small amount of good quality pipe thread compound or plumbers tape suitable for the gas being used. Thread compound should be used sparingly on male threads only, leaving the first two threads clean.
1. Install the gas valve so gas flow conforms with the inlet gas flow indicated on the valve body. A wrench should only be used on flat surfaces of the inlet boss. Never use a wrench on the body of the valve as this may distort the casting.
 2. A sediment trap must be present in the gas supply line. If one is not present one must be installed to prevent dirt from entering the control. See Figure 9. All piping must conform to local codes and ordinances and with National Gas Codes (ANSI Z223.1 and NFPA No. 54).

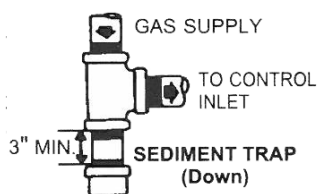

Figure 9

3. The valve should be mounted with the wiring terminals at the top for easy access in installation of wiring and fixture service testing.

WARNING: Do not mount valves upside down.

4. Connect the pilot tubing to the pilot gas outlet. Use the fitting provided and tighten for gas seal. Do not bend the tubing after tightening.

NOTE: Valves have a built-in vent limiter. The regulator vent is tapped so a tubing adaptor can be installed if vent tubing is required by local codes.



CAUTION

If bleed tubing is used, do not allow main burner or pilot flame impingement on the tubing as this will eventually cause clogging of the tubing and improper regulator operation. If bleed tubing is not used, the regulator vent must be properly shielded from moisture.

Flame must not impinge on regulator vent tubing if used, it may clog and cause gas valve to malfunction.

All components must be securely mounted with screws, bolts etc., within the appliance.

WIRING THE IGNITION CONTROL UNIT

1. Wiring must conform to local codes and ordinances. A high limit switch is required in either the 120V or 24V side of the transformer.
2. Make certain all wiring connections are tight.
3. The 712 series pilot ignition kits include a six-wire (blue) harness assembly. This harness assembly connects the gas valve to the ignition control unit. To wire the ignition control unit:
 - A. Attach blue wire to terminal "PV" (pilot valve, pilot gas).
 - B. Attach red wire to terminal "MV" (main valve, main burner).
 - C. Attach gray wire to terminal "TH" (thermostat).
 - D. Attach green wire to "GND" terminal.
 - E. Attach black/white wire to terminal "MV/PV" (common).

NOTE: The white and black wires are assembled into one quick-connect terminal and it is normally attached to the MV/PV terminal. However, the GND, MV/PV and TR terminals are electrically identical, and the green, white and black wires may be attached to any of these terminals.

4. If the appliance has an automatic vent damper, verify that damper is in the full open position. We recommend that the 712 series kit be installed and tested as instructed in SYSTEM CHECKOUT PROCEDURES prior to connecting the vent damper into the system.

5. Locate ground terminal connector.

WARNING: Gas valve must be grounded to prevent burnout of gas valve terminal circuit board.

- A. The 7000 Series Gas Valve is included in the following kits: 712-006, -009, -016 and -019. Attach ground terminal connector to the top of the gas valve.

- B. The 7200 Series Gas Valve is included in the following kits: 712-008 , -015 and -017. Attach the grounding terminal to the gas valve.
- C. The 2000 Series Gas Valve is included in the following kits: 712-005 and 712-022. Attach the green ground wire in the wiring harness to the terminal on the gas valve.

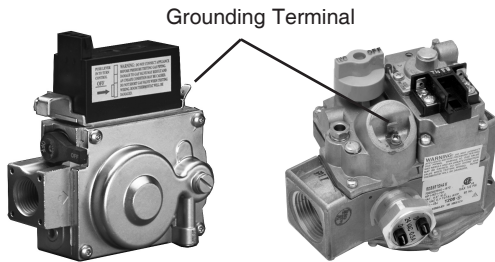

Figure 10

- 6. Locate the green wire in the six-wire harness. Be sure that this wire is connected to the GND terminal on the ignition unit and to the gas valve - **see page 10**.
- 7. Locate the separate ground wire included in the 712 kit. Connect the "ring" terminal to the mounting screw that attaches the pilot assembly to the furnace. Connect the other end to the "TR" terminal on the ignition control unit.
- 8. The six-wire harness is used to connect the ignition control unit to the gas valve and to the thermostat control circuit. Determine which gas valve type you have (7000, 7200 or 2000) and proceed as directed by the following instructions.
- 9. Some appliance wiring may result in one terminal of the secondary side of the transformer being grounded. If this condition exists, damage to the transformer may occur if the two wires (black and gray) in the wiring harness are connected improperly to the two wires removed from the old gas valve. It is necessary to determine which wire is grounded before proper connection to the wiring harness can be made.
 - A. Be sure all gas to the appliance is turned off. Make sure the two wires removed from the old gas valve will not touch the furnace chassis or each other.
 - B. Turn on the electrical power to the furnace and set the thermostat to the high setting.
 - C. Set the test meter to the 24 volt AC scale. Touch or clamp one meter probe to the chassis of the furnace.
 - D. Touch the other probe of the meter to each wire, one at a time.
 - E. If no meter reading is obtained, the two wires removed from the old gas valve may be connected to either wire (black or gray) in the new wiring harness. If a 24 volt reading is obtained at one wire, that wire must be connected to the gray wire in the wiring harness.

7000 SERIES GAS VALVES

When installing kit numbers 712-006, -009, -016, and -019, refer to the wiring diagrams shown below. This illustrates the wiring method when using a 7000 series gas valve. The wiring connections at the gas valve are as follows:

1. Locate the 4" white jumper wire in the kit.
2. Attach one end (quick-connect) to one terminal of the solenoid valve. Attach the other end to the screw terminal "TR" on the gas valve operator.
3. Connect the white wire in the wiring harness to the quick connect terminal at "TR".
4. Connect the red wire to the "TH" terminal on the gas valve.
5. Attach the blue wire which has a non-insulated connector to the solenoid pilot valve.
6. Attach green wire to the ground terminal on the gas valve.
7. Connect the wire from the pilot ignitor/sensor to the "IGN" terminal on the ignition control unit.
8. With all wiring completed to this point, return to step 9 in the WIRING THE IGNITION CONTROL UNIT section and proceed as directed.

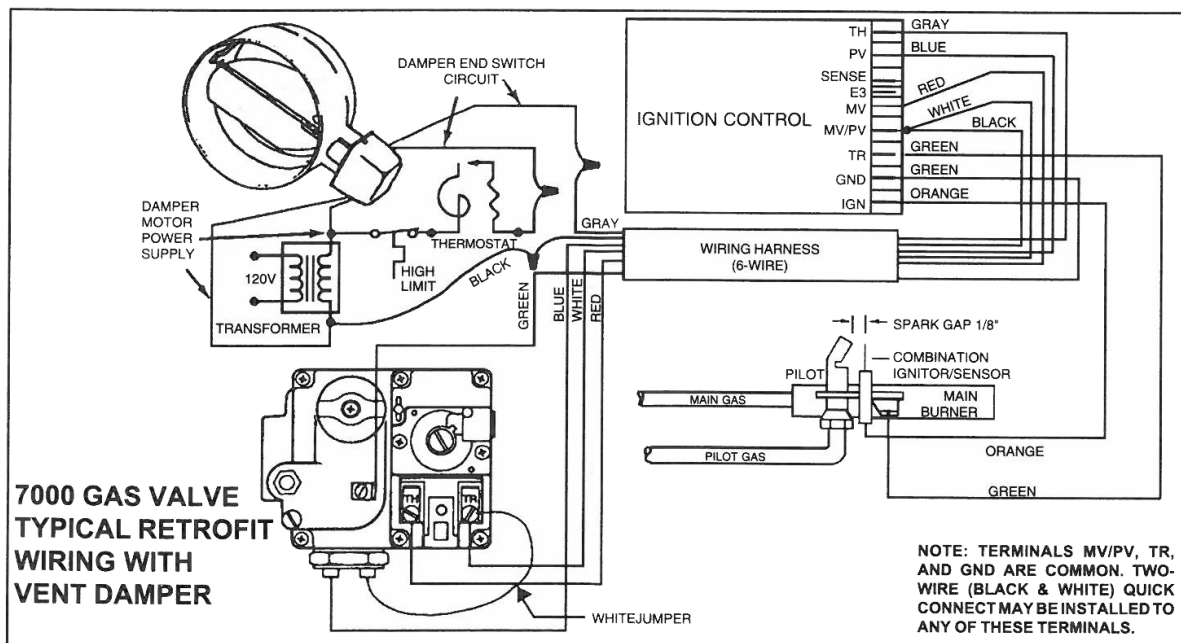
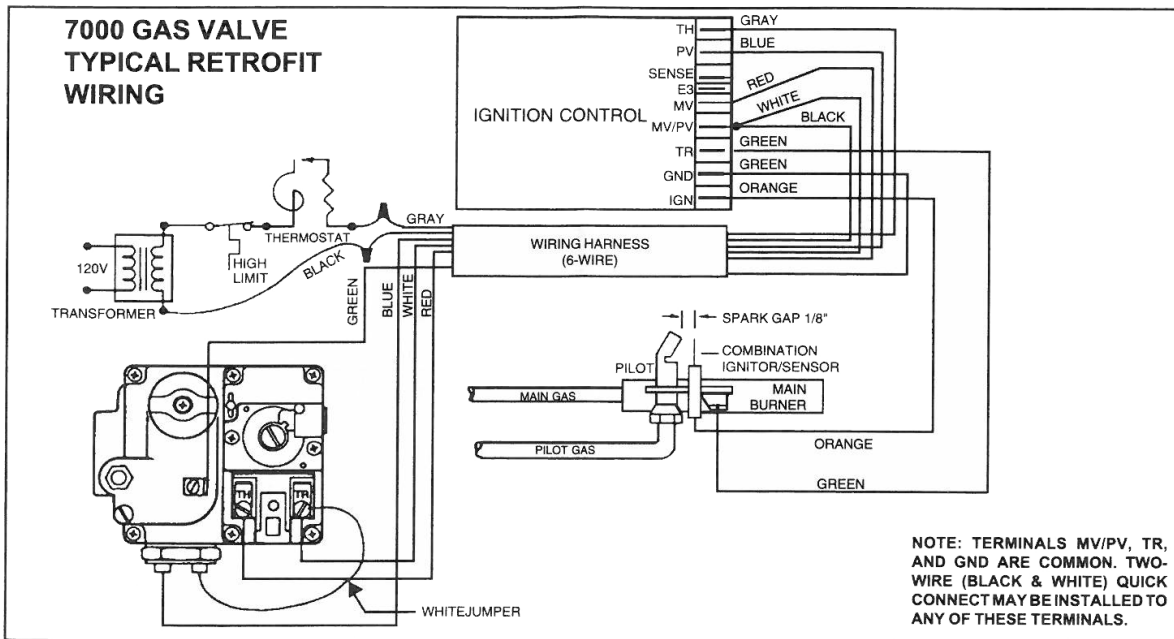

7200 SERIES GAS VALVES

When installing kit numbers 712-008, 712-015, and 712-017, refer to the diagrams shown below. This illustrates the wiring method when using a 7200 series gas valve. The wiring connections at the gas valve are as follows:

1. Attach the blue wire which has a non-insulated connector to terminal "P" on the gas valve connector.
2. Attach the white wire to terminal "C".
3. Attach the red wire to terminal "M".
4. Attach green wire to the ground terminal.

5. Connect the wire from the pilot ignitor/sensor to the "IGN" terminal on the ignition control unit.
6. With all wiring completed to this point, return to step 9 in the WIRING THE IGNITION CONTROL UNIT section and proceed as directed.

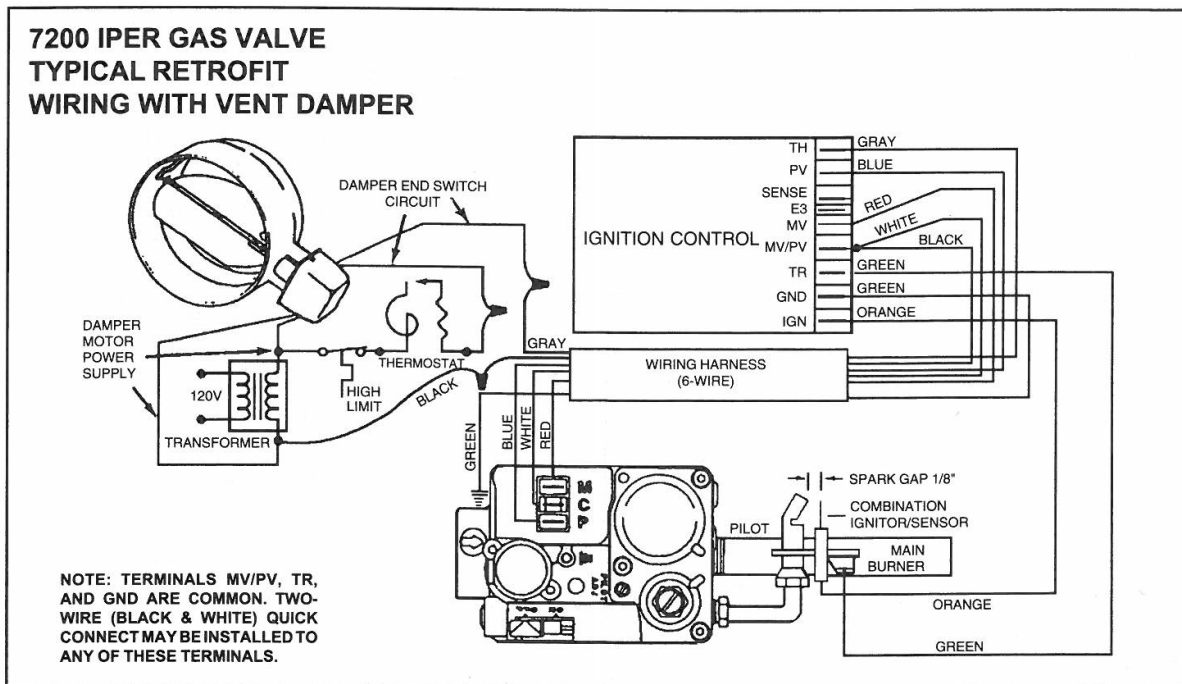
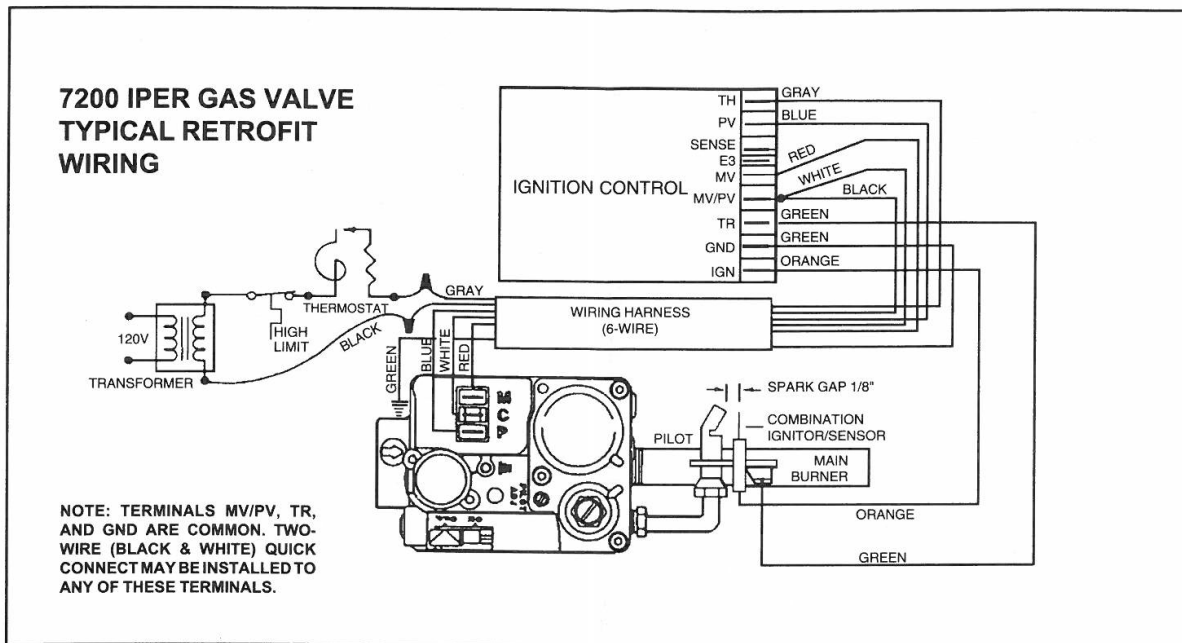

2000 SERIES GAS VALVES

When installing kit numbers 712-005 and 712-022, refer to the diagrams shown below. This illustrates the wiring method when using a 2000 series gas valve. The gas valve connections are made by a plug-in terminal.

1. Attach green wire to ground terminal.
2. Connect the wire from the pilot ignitor/sensor to the "IGN" terminal on the ignition control unit.
3. With all wiring completed to this point, return to step 9 in the WIRING THE IGNITION CONTROL UNIT section and proceed as directed.

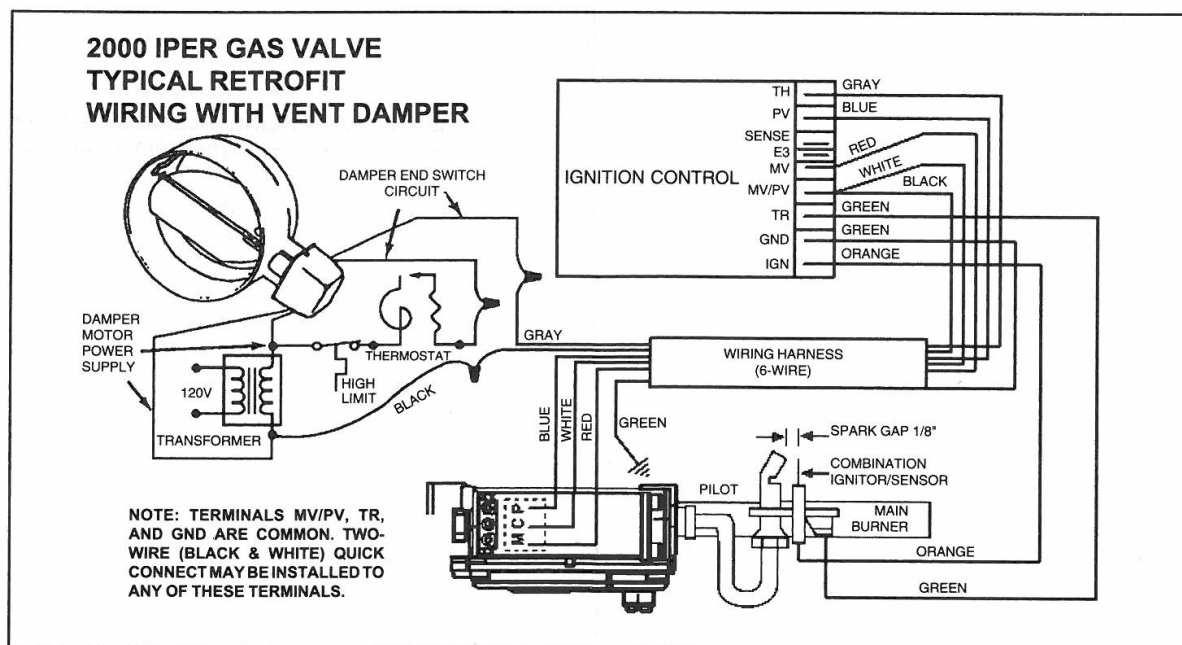
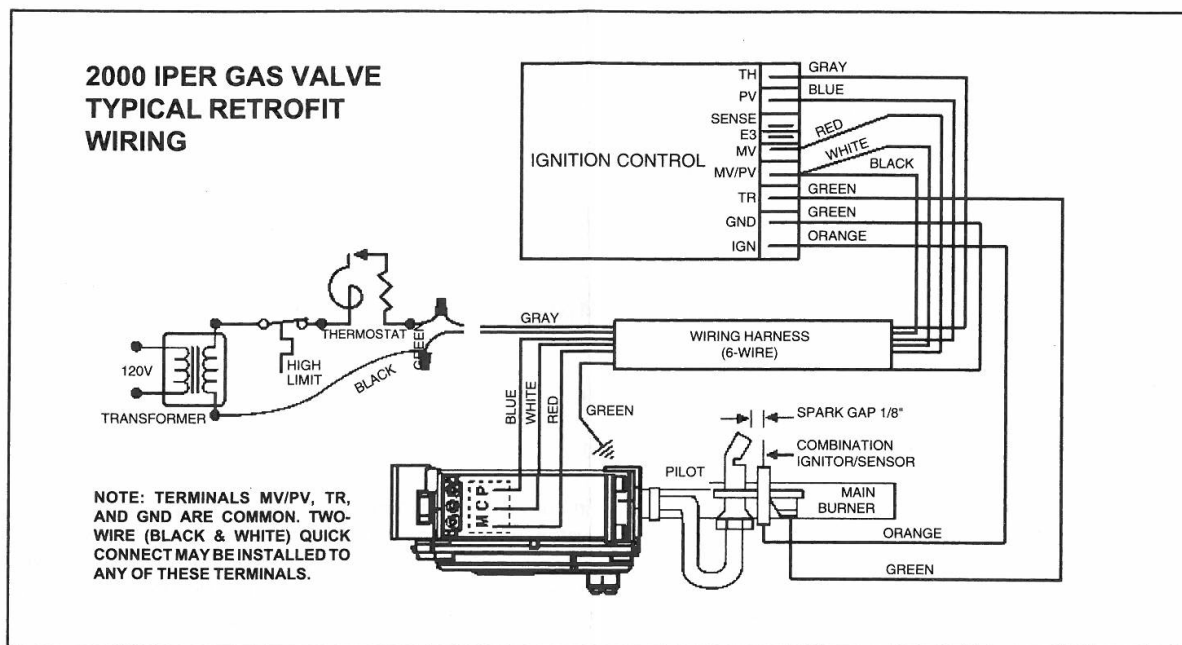

SYSTEM CHECKOUT PROCEDURES

The initial installation portion is now completed. The checkout procedures listed below must be followed. While there are redundant safety features built into the system, it is imperative that you follow the steps outlined below to ensure proper and safe operation. If you encounter any irregularities, refer to the TROUBLESHOOTING GUIDE.

1. Check all wiring connections.
2. Turn on main gas supply and put the manual valve or selector arm on the gas valve into the "ON" position.
3. Use a leak test solution to check piping for gas leaks. Repair if needed.
4. Turn on electrical power.
5. Set thermostat to high.

WARNING: Vent damper must be in the fully open position before the ignition system is energized. Failure to verify this may cause a serious health hazard to occupants.

6. Sparking begins, pilot gas ignites.
7. Pilot flame on ignitor/sensor, main burner on.
8. If the ignition control unit is a 780-715, with main burner on, cycle thermostat off then on. System will turn off and immediately on again.
9. With the main burner on, turn the manual gas valve to off position. Wait until all flame is out. Turn manual gas valve on again.
 - A. Sparking will begin as soon as the pilot flame is out.
 - B. Pilot ignition takes place when gas flow is restored.
10. **If the ignition control unit is a 780-845 (lockout):**
With the main burner on, turn the manual gas valve off. Sparking will begin when the pilot flame goes out. After 90 seconds the system will go into time delay (6 minutes) and sparking will cease. The lockout ignition control used provides 90 seconds of spark followed by a six minute time delay (purge) period between ignition attempts. After three tries, if no pilot flame is sensed, a 1-hour lockout period will begin. At the end of the 1-hour lockout period, if the demand for heat is still present, unit repeats the three tries for ignition.

11. Check manifold pressure and compare the reading with those obtained in the PRE-INSTALLATION - SAFETY INSPECTION PROCEDURES. Adjust pressure regulator (if necessary) to match the original input.
12. Visually determine that the main burner is burning properly, as it was during the PRE-INSTALLATION - SAFETY INSPECTION PROCEDURES; i.e., no floating, lifting, or flashback. Adjust the primary air shutter(s) as required.
13. It is absolutely necessary that the system be cycled normally (thermostatically controlled) through at least three complete heating cycles. Set thermostat to a temperature slightly higher (at least 5°) than the existing ambient. Allow the appliance to cycle ON and run through a normal cycle. Do not manually shorten the cycle.
14. **Applicable only to furnaces:** Check both the limit control and the fan control for proper operation. Limit control operation can be checked by blocking the circulating air inlet or temporarily disconnecting the electrical supply to blower motor. Determine that the limit control acts to shut off the main burner gas. Applicable only to boilers: Determine that the circulating water pumps are in operating condition. Test low water cutoffs, automatic feed controls, pressure and temperature limit controls, and relief valves in accordance with the manufacturer's recommendation to determine they are in operating condition.
15. The initial checkout procedures have been completed. If the system has functioned normally, return thermostat setting to its normal setting. The qualified installing agency must completely fill out and apply the yellow appliance conversion sticker to the front of the appliance. Leave these and all other instructions with the homeowner.

TROUBLESHOOTING GUIDE

PILOT IGNITION SYSTEM / FLAME RECTIFICATION / IGNITION CONTROL UNITS 780-715 AND 780-845

There are five potential problem conditions with the thermostat set high.

To perform the following test you will need a volt /ohmmeter. Refer to your appropriate wiring diagrams.

The ignition control can also be tested, using the Robertshaw ignition control tester, part number 900-575.

Problem #1: Thermostat on, no spark, no pilot gas.

Possible Causes:

- A. No main power
- B. Faulty transformer
- C. Faulty thermostat
- D. Faulty limit
- E. Faulty ignition control unit

Solution:

1. With power on and thermostat set high, set your test meter to the 24 volt scale. Probe terminals TH and TR. If you do not read 24 volts, the problem is not the ignition system. Perform normal system checks of main power, transformer, thermostat and the limit control. If you do read 24 volts at TH and TR the problem is in the ignition system. Check for loose or defective wiring. If wiring is good replace the ignition control unit.

Problem #2: Have spark, no pilot gas flow.

Possible Causes:

- A. Main gas supply turned off
- B. Manual valve on gas valve turned off
- C. Faulty primary valve in the gas valve
- D. Faulty wire connection
- E. Faulty ignition control unit

Solution: Set test meter to 24 volt scale.

1. Be sure main gas valve (gas cock or selector arm) is turned on.
2. With gas on and the system sparking, probe terminals PV and TR. If 24 volts is read at these terminals and pilot gas does not flow, replace the gas valve.
3. If you do not read 24 volts at terminals PV and MV/PV replace the ignition control unit.

Problem #3: Have pilot gas, no spark.

Possible Causes:

- A. Defective ignitor/sensor and/or its wiring
- B. Faulty ignition control unit

Solution: Set test meter to ohm scale.

1. Disconnect the wire from the IGN terminal on the ignition control unit.

2. Touch one meter probe to the tip of the ignitor/sensor rod in the pilot. Touch the other probe to the quick-connect at the other end of the ignitor/sensor wire.
3. If you have continuity from the tip of the ignitor/sensor rod to the connector and no spark, replace the ignition control unit.
4. If you do not have continuity through the wire and the ignitor/sensor, check for loose wire connection in the wire. Repair as needed.
5. Check to see if spark shorts to furnace through a cut in the ignitor wire.

Problem #4: Have pilot flame, main burner will not turn on.

Possible Causes:

- A. Faulty main valve coil in the gas valve
- B. Faulty ignitor/sensor and/or its wiring
- C. Ground wire not attached to furnace chassis
- D. Flame rectification signal from pilot to ignition control unit weak
- E. Faulty ignition control unit

Solution: Set test meter to 24 volt scale.

1. With pilot flame on ignitor/sensor - probe terminals MV and MV/PV on the ignition control unit. If you read 24 volts here, but not at the gas valve, there is a loose wiring connection. Repair or replace as needed.
2. If you do read 24 volts at MV and MV/PV and the pilot flame is impinging on the ignitor/sensor rod, the problem may be:
 - Faulty ignitor/sensor and/or its wiring
 - Faulty ignition control unit
 - No flame rectification signal to ignition control unit.
3. Set test meter to the ohm scale. Set thermostat low-system off.
4. Check continuity through the green ground wire between the pilot mounting bracket and the ignition control unit. Repair or replace as needed.
5. Check continuity through the green ground wire between the gas valve and the ignition control unit. Repair or replace as needed.
6. Check ignitor/sensor for continuity, through the spark/sensor rod. Also, check ignitor/sensor ceramic for cracks. Repair or replace as needed.
7. Reconnect all wires that were disconnected, including the ignitor/ sensor wire and the ground wire.
8. Set thermostat high. With the pilot burning and the flame on the ignitor/sensor rod, if the main burner does not turn on - replace the ignition control unit.

**Problem #5: Short-cycling of main burner.
Main burner turns off before the thermostat
is satisfied.**

Possible Causes:

- A. Draft condition pulls pilot flame away from ignitor/
sensor rod
- B. Incorrect thermostat anticipator setting
- C. Pilot flame gets smaller when main burner
comes on.
- D. Faulty limit control

Solution:

1. Check the thermostat anticipator setting. Set to .7 amp.
A lower setting will cause short-cycling.
2. Set thermostat high, with main burner on, observe the
pilot flame impingement on the ignitor/sensor rod.
 - If pilot flame is small and draft condition pulls flame
from ignitor/sensor rod the burner will turn off and
then on again.
 - Adjust pilot flame higher or clean pilot orifice.
 - Bend ignitor/sensor rod closer to pilot flame .
3. If flame impingement on the ignitor/sensor is stable and
the system short-cycles, check the limit switch.
4. Set test meter to 110 volt scale.
 - When the system cycles off, probe the switch
terminals of the limit switch.
 - If you read 110V or 24V across the switch terminals
the limit switch is open. Replace the limit switch.
5. A pilot flame set too high will also cause burner to short
cycle. Pilot flame lifts over ignitor/sensor.



Customer Service Telephone 1.800.304.6563
Customer Service Facsimile 1.800.426.0804
HVACCustomerService@robertshaw.com

For Technical Service
Telephone 1.800.445.8299
Facsimile 1.630.260.7294
TechnicalService@robertshaw.com

Robertshaw®, Ranco®, Paragon® and Uni-Line® is a trademark of Robertshaw its subsidiaries and/or affiliated companies. All other brands mentioned may be the trademarks of their respective owners.

www.Uni-Line.com
www.Robertshaw.com
©2014 Robertshaw
10/14 - 1-963 Rev D