



TJERNLUND PRODUCTS, INC.

1601 Ninth Street • White Bear Lake, MN 55110-6794
 PHONE (800) 255-4208 • (651) 426-2993 • FAX (651) 426-9547
 Visit our web site • www.tjernlund.com

AUTO-DRAFT® INDUCER INSTALLATION INSTRUCTIONS

MODELS

DJ-3

IL

D-3

XL

I

HD

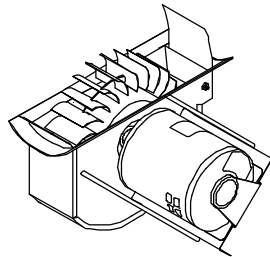

OWNER INSTRUCTIONS, DO NOT DESTROY

▲ Recognize this symbol as an indication of important Safety Information!

NOTE: FLUE GAS TEMPERATURES MUST NOT EXCEED 575°F AT DRAFT INDUCER INLET. DRAFT INDUCERS MUST NOT BE USED FOR SIDEWALL VENTING APPLICATIONS.

▲ WARNING

THESE INSTRUCTIONS ARE INTENDED AS AN AID TO QUALIFIED, LICENSED SERVICE PERSONNEL FOR PROPER INSTALLATION, ADJUSTMENT AND OPERATION OF THIS UNIT. READ THESE INSTRUCTIONS THOROUGHLY BEFORE ATTEMPTING INSTALLATION OR OPERATION. FAILURE TO FOLLOW THESE INSTRUCTIONS MAY RESULT IN IMPROPER INSTALLATION, ADJUSTMENT, SERVICE OR MAINTENANCE POSSIBLY RESULTING IN FIRE, ELECTRICAL SHOCK, CARBON MONOXIDE POISONING, EXPLOSION, PERSONAL INJURY OR PROPERTY DAMAGE.

**DO NOT DESTROY. PLEASE READ CAREFULLY AND
 KEEP IN A SAFE PLACE FOR FUTURE REFERENCE.**

TABLE OF CONTENTS

DESCRIPTION	PAGE(S)
DESCRIPTION	1
SPECIFICATIONS	1
CAUTIONS	1
INSTALLATION RESTRICTIONS	2
DRAFT INDUCER SELECTION TABLE	2
PS1505 FAN PROVER SAFETY INTERLOCK INSTALLATION	3
INSTALLATION	3 - 5
ELECTRICAL WIRING	5 - 9
TYPICAL GAS DIAGRAMS	5 - 8
TYPICAL OIL DIAGRAMS	8 - 9
OPERATION CIRCUIT CHECK	9 - 10
P/N 950-1067 POST PURGE RELAY/TIMER ADJUSTMENT	10
COMBUSTION AIR & SAFETY INTERLOCK TEST	10
DRAFT CONTROL	10
MAINTENANCE	10 - 11
HOW TO OBTAIN SERVICE & LIMITED WARRANTY	11
REPLACEMENT PARTS	11

Tjernlund Products welcomes your comments and questions. Call us at (651) 426-2993, (800) 255-4208, Fax (651) 426-9547, email us at fanmail@tjfans.com or write to: Customer Service, Tjernlund Products, Inc., 1601 Ninth Street, White Bear Lake, MN 55110-6794.

DESCRIPTION

TJERNLUND AUTO-DRAFT® Inducers assure positive draft when restricted boilers and furnaces, poor chimneys or slight negative pressures in buildings prevent proper exhaust of combustion gas. The venturi action of Tjernlund Auto-Draft Inducers starts air moving smoothly. These units are quick and easy to install and completely automatic in operation. Tjernlund's unique design and durable construction makes them trouble-free and reduces maintenance to a minimum. The Vari-Draft Control permits adjustments to the individual job requirement.

SPECIFICATIONS

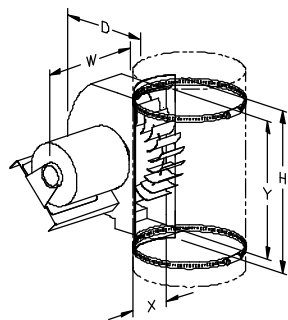

“H” - OVERALL HEIGHT
“D” - OVERALL DEPTH
“W” - OVERALL WIDTH
“X” - PIPE SLOT WIDTH
“Y” - PIPE SLOT HEIGHT

MODEL NO.	UNIT DIMENSIONS(IN)			SLOT		SHIP WT.
	H	W	D	X	Y	
DJ-3	7 1/2	8 1/2	5 7/8	2 5/8	7 5/8	8 LBS
D-3	9 1/8	9 1/2	7	3 1/8	8 5/8	10 LBS
I	14 1/2	13 1/2	8 3/4	4	12 3/4	30 LBS
IL	17	14 3/4	10	4 1/4	14 3/4	36 LBS
XL	18 7/8	18 1/2	10 1/2	4 3/4	16 3/4	55 LBS
HD	27 1/2	16 3/4	25	6	24 1/2	176 LBS

CAUTIONS

WARNING

Disconnect the power supply when making wiring connections or when working around the fan wheel and motor. Failure to do so can result in electrical shock, personal injury, death or property damage.

1. All wiring must comply with applicable codes and ordinances.
2. When wiring is completed, check all components by running system through its entire heating cycle. See “Operation Circuit Check” on page 9 and “Safety Interlock / Combustion Air Test” on page 10.
3. Check vent pipe system for leakage. All vent system leaks must be sealed prior to the installation of the Draft Inducer.
4. Plan the vent system so that Code required distances are maintained from plumbing and wiring.
5. Make certain the power supply is adequate for the Draft Inducer motor requirements. Do not add the Draft Inducer to a circuit where the total load is unknown. For Draft Inducer motor amperage see “Draft Inducer Selection Table” on page 2.
6. The Draft Inducer shall not be installed where flue gas temperatures exceed 575°F at the Draft Inducer Inlet. Ambient temperatures must not exceed 104 degrees F. Item #4 under “Installation Restrictions” describes how to measure flue gas temperatures.
7. A safety inspection of an existing appliance must be performed before installation of the Draft Inducer as outlined in ANSI Z223.1/NFPA #54, Appendix H.

INSTALLATION RESTRICTIONS

⚠ WARNING

Failure to install, maintain and/or operate the Draft Inducer in accordance with manufacturer's instructions may result in conditions which can produce bodily injury and property damage.

⚠ WARNING

The Draft Inducer must be installed by a qualified installer in accordance with these instructions and all local codes or in their absence in accordance with the latest editions of The National Fuel Gas Code (NFPA #54), Installation of Fuel Burning Equipment (NFPA 31), Chimneys, Fireplaces, Vents, and Solid Fuel Burning Appliances (NFPA 211), The National Electrical Code (NFPA#70) and the Occupational Safety and Health Act (OSHA) when applicable. Improper installation can create a hazardous condition such as an explosion, fire, electrical shock or carbon monoxide poisoning resulting in property damage, personal injury or death.

1. The Draft Inducer shall not be used on condensing heating equipment.
2. Oil burning installations and gas-fired units without a draft hood / diverter should include a barometric draft regulator.
3. The Draft Inducer motor shaft must be mounted horizontally to prevent motor bearing wear.
4. The Draft Inducer shall not be installed where flue gas temperatures exceed 575°F at the Draft Inducer Inlet. Ambient room temperatures must not exceed 104 degrees F.

Flue gas temperature verification:

A) Consult appliance manufacturer for temperature of gases at the appliance outlet after dilution by draft hood, draft diverter or barometric draft control.

AND

B) Measure temperature of flue gases at the Draft Inducer inlet at time of installation. Temperature should be measured after appliance and Draft Inducer have operated for at least 10 minutes, allowing flue gas temperature to stabilize.

DRAFT INDUCER SELECTION TABLE

1. Inputs shown are believed to be maximum capacities for inducers when mounted on pipe sizes shown for ordinary jobs where a moderate amount of mechanical induced draft is required.
2. Consideration is given to typically higher static pressure requirements for larger installations, for the type of fuel burned and for the type of draft control installed.
3. Where pressure requirements are unknown or believed to be unusually severe, ask for complete performance curves or consult factory.
4. All ratings have been developed in our testing and research department and have been approved by a nationally known independent testing laboratory. Certification is available upon request.
5. Heating capacities shown are for 1000 BTU per cubic foot natural gas and for 139,000 BTU per gallon No. 2 fuel oil. Consult factory for capacities with other fuels. Heating capacities are based on typical combustion efficiencies and allow for approximately 5 percent ambient air drawn into inducer to cool motor and drives.
6. Draft Inducers should be installed in single wall vent pipe in order to insure proper performance.

MODEL	PIPE SIZE IN.	GAS FIRING WITH DRAFT HOOD				GAS FIRING WITH BAR. DRAFT CONTROL				OIL FIRING WITH BAR. DRAFT CONTROL				ELECTRICAL DATA					
		HEATER BTU INPUT		270°F FLUE GAS		HEATER BTU INPUT		390°F FLUE GAS		HEATER BTU INPUT		530°F FLUE GAS		VOLTS	HZ	RPM	WATTS	AMPS	THERM PROT.
		S.P.	CFM	S.P.	CFM	S.P.	CFM	S.P.	CFM	S.P.	CFM								
DJ-3	3	69,000	.034	48	72,000	.047	36	58,000	.048	33	115	60	1550	35	.43	IMP. PROT.			
	4	105,000	.042	72	109,000	.053	55	92,000	.057	48									
	5	111,000	.043	72	104,000	.052	52	74,000	.052	39									
	6	100,000	.041	68	34,000	.042	17	25,000	.035	13									
D-3	5	270,000	.063	190	330,000	.085	166	295,000	.092	163	115	60	1550	74	.96	YES			
	6	356,000	.073	246	377,000	.090	190	300,000	.093	169									
	7	360,000	.075	259	330,000	.085	166	230,000	.080	118									
	8	320,000	.068	217	222,000	.075	110	123,000	.065	65									
I	8	900,000	.125	590	1,200,000	.143	603	1,100,000	.147	566	115	60	1725	1/4HP	5.4	YES			
	9	1,110,000	.135	765	1,330,000	.150	653	1,100,000	.148	566									
	10	1,250,000	.140	850	1,260,000	.145	615	840,000	.136	440									
	12	1,030,000	.128	710	710,000	.115	357	400,000	.100	211									
IL	9	1,460,000	.145	1010	1,970,000	.175	989	1,700,000	.180	900	115	60	1725	1/4HP	5.4	YES			
	10	2,080,000	.170	1370	2,460,000	.185	1240	1,900,000	.180	1010									
	12	1,920,000	.160	1325	2,230,000	.182	1120	1,500,000	.170	789									
	14	1,840,000	.159	1270	1,470,000	.158	740	825,000	.135	453									
	16	900,000	.120	620	650,000	.113	340	350,000	.095	184									
	18	650,000	.099	450	440,000	.095	220	200,000	.075	106									
XL	16	4,000,000	.250	2760	4,000,000	.260	2010	3,300,000	.230	1763	115 208 230	60	1725	3/4HP	11.0 5.4 5.3	YES			
	18	3,900,000	.240	2650	3,250,000	.240	1660	2,100,000	.190	1103									
	20	2,800,000	.195	1935	2,100,000	.175	1079	1,200,000	.150	626									
	24	1,500,000	.150	1035	1,100,000	.125	527	503,000	.110	266									
HD	20	5,300,000	.290	3690	5,200,000	.270	2440	3,600,000	.240	1870	208 230 460	60	1725	2 HP	6.3 6.4 3.2	NO			
	24	3,500,000	.220	2415	3,750,000	.220	1660	2,900,000	.218	1550									

MODEL PS1505 FAN PROVING SWITCH SAFETY INTERLOCK

The Model PS1505 Fan Proving Switch works on all Tjernlund Draft Inducers to assure adequate draft is present before burner is allowed to fire. The PS1505 complies with burner safety interlock provisions of National Mechanical Codes.

PURPOSE

The PS1505 Fan Prover has been designed to monitor the pressure within the fan housing only. A motor or wheel failure will decrease housing pressure and deactivate the pressure switch thus preventing combustion.

The PS1505 Fan Prover is not a safety control designed to ensure proper draft or to indicate chimney failure. It is the responsibility of the end user to properly maintain the combustion equipment and its chimney or vent. Yearly maintenance and inspection should be conducted by qualified service personnel. Failure to follow such maintenance and inspection procedures may result in generation of toxic carbon monoxide gas.

LOCATION

The PS1505 Fan Prover can be mounted on any vertical surface within five (5) feet of the draft inducer. It must not be mounted on the inducer or any other surface with a temperature in excess of 190° F. Similarly, the temperature of the surrounding air must be less than 190° F.

RATING

15 Amps non-inductive to 277 Volts AC.

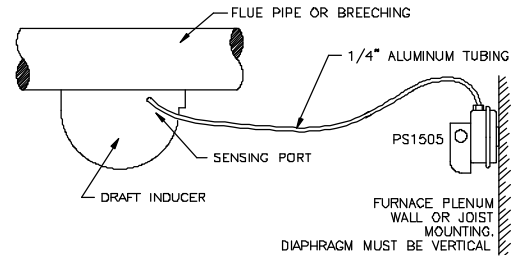

INSTALLATION

CODE REQUIREMENTS

The Draft Inducer must be installed by a qualified installer in accordance with these instructions and all local codes or in their absence in accordance with the latest editions of The National Fuel Gas Code (NFPA #54), Installation of Fuel Burning Equipment (NFPA 31), Chimneys, Fireplaces, Vents, and Solid Fuel Burning Appliances (NFPA 211), The National Electrical Code (NFPA#70) and the Occupational Safety and Health Act (OSHA) when applicable.

- All appliances must enter the vent system on the inlet side of the Draft Inducer.
- Provision shall be made to interlock the appliance(s) to prevent the flow of gas to the main burners when the draft system is not performing so as to satisfy the operating requirements of the equipment for safe performance. See "Electrical Wiring" on page 5.

INSTALLER NOTES

1. Verify Draft Inducer selection using burner specifications and Draft Inducer Selection Table on page 2.
2. Make certain that the electrical requirements of the Draft Inducer shown on page 2 are fulfilled by the available power supply.

HIGH TEMPERATURE GASKET MATERIAL MOUNTING (MODELS I, IL, XL ONLY)

1. Peel tape backing off 6 inches on one end.
2. Apply peeled end to the housing flange at a corner of the unit.
3. Press thumb along the top side and peel backing as tape is applied to flange.
4. Insure a tight fit where gasket ends meet.

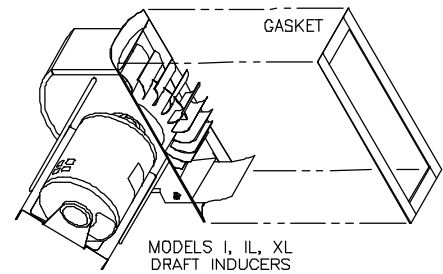

MOUNTING

WARNING

The Draft Inducer must not be used in sidewall venting applications. Sidewall venting requires the use of a Tjernlund Sidewall Power Venter.

1. The Draft Inducer may be mounted on vertical, horizontal or inclined smokepipe. If used on a horizontal smokepipe, mount inducer on bottom of pipe, not on top, to avoid creating a heat trap in inducer.
2. Cut rectangular slot in pipe and fasten in place with mounting bands provided. NOTE: The models DJ-3 & D-3 do not require bands, use mounting screws provided.
3. Select a position between draft hood, draft diverter or barometric damper and chimney, locating the inducer as near the chimney as possible. The motor shaft must be level and horizontal to avoid excessive wear of bearings.

4. Do not use "bullhead" tees when connecting two smoke pipes together. When tees are necessary, connect at 45° degree angles or less. If change in smokepipe size is required, use a tapered increaser or reducer.

SIMPLE INSTALLATION

1. CUT SLOT IN PIPE



2. INSERT INDUCER



3. INSTALL BANDS

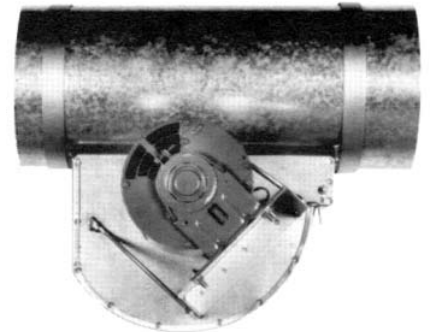

(Model DJ-3 & D-3 fastened with screws)

NOTE: Inducer is shown tilted in above pictures to show slot. Actual installation must have shaft horizontal.

INSTALLATION POINTERS

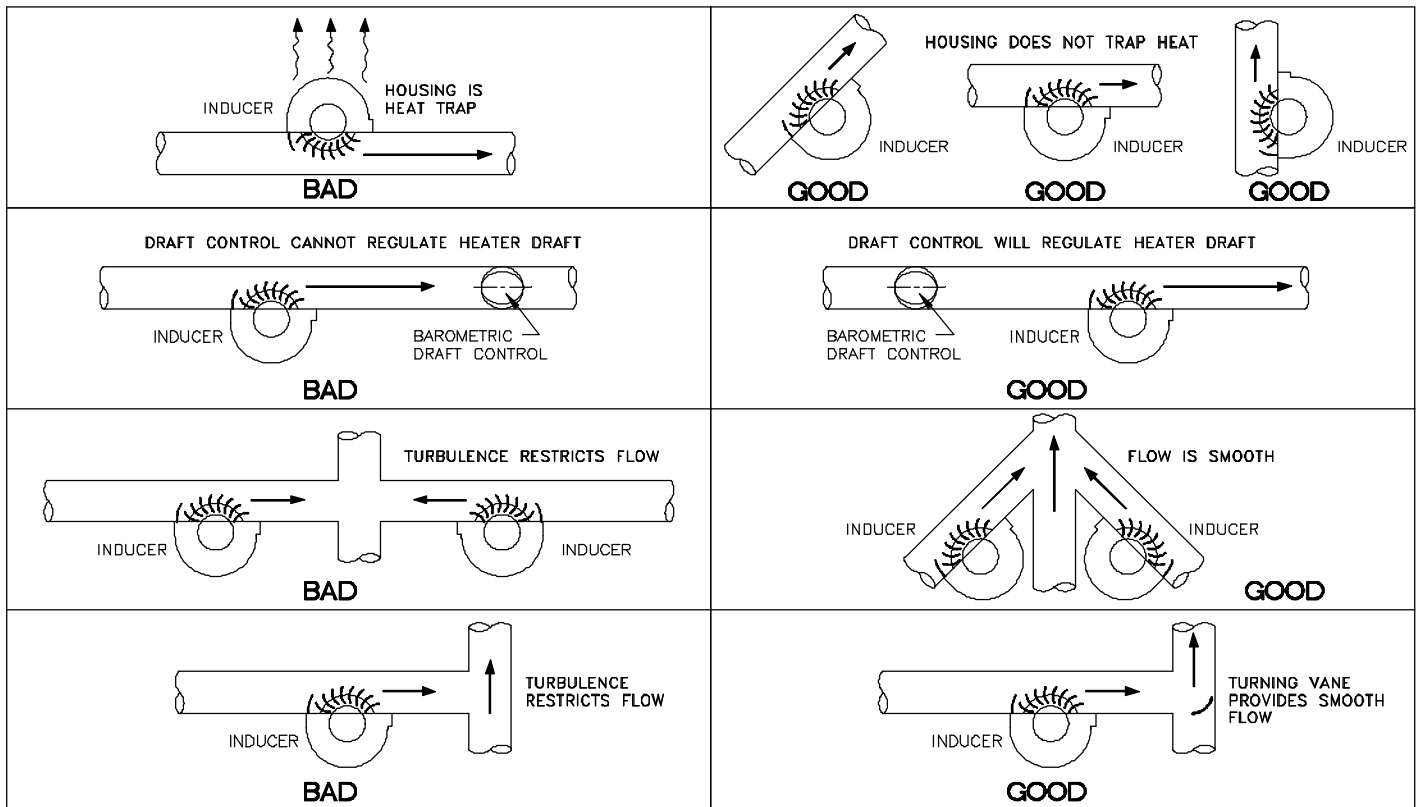

SPECIAL APPLICATIONS

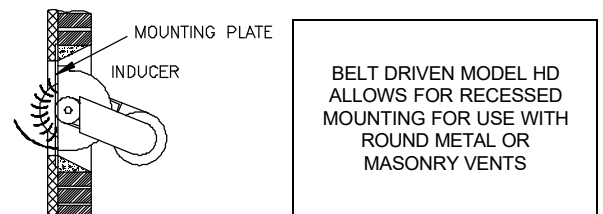
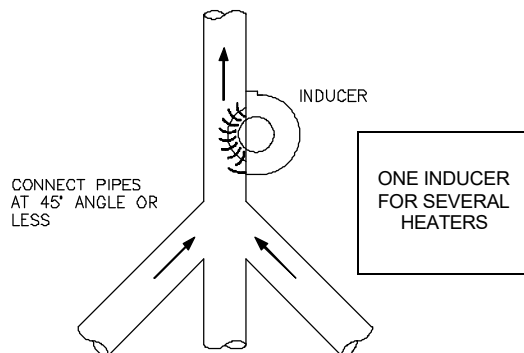

TYPICAL INSTALLATION

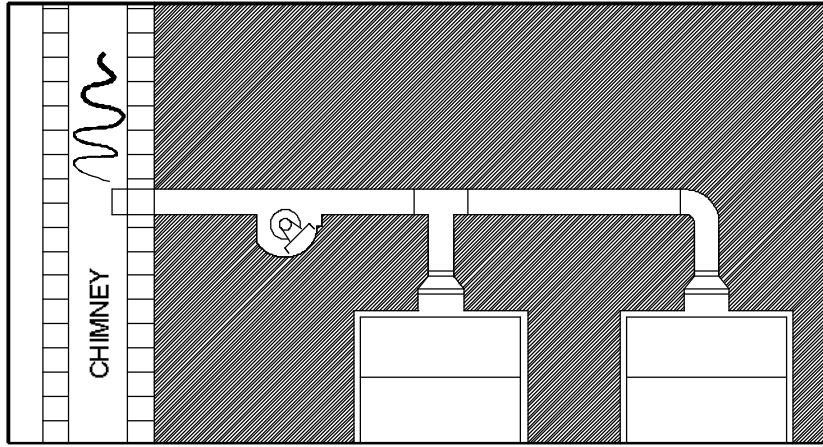

ELECTRICAL WIRING

Wiring diagrams are included in these instructions for various draft inducer applications. While it would be impractical to show every conceivable variation, the ones included will demonstrate sufficient basic techniques for the design and installation of the unusual control system.

The installer should always check the rated capacity of a burner primary control. If the amperage rating of the load contacts is not equal to the sum of all burner components plus that of the inducer motor, an additional isolation relay must be installed as shown in some diagrams. Draft inducer motor amperage ratings can be found on the "Draft Inducer Selection Table" on bottom of page 2.

The diagrams included show wiring for the standard motors furnished with the inducers. If special voltage motors have been specified, changes in wiring may be necessary.

Wiring diagrams assume all inducer motors (except Model HD) will have 115 volt service. The Model XL is furnished with 115/230 volt motors. If 230 volt service is required for this unit, consult factory if necessary, for wiring instructions.

The amperage rating of the PS1505 Fan Prover is 15 amps non-inductive to 277 volts AC.

A Post Purge Relay/Timer (P/N 950-1067) should be installed on Draft Inducers when venting Oil Fired Equipment. This will allow the venter to run from 1 to 10 minutes after a heating cycle to purge the vent system of any residual flue gases or oil odors. The Relay/Timer can also be installed on gas installations with extended horizontal vent connectors.

GAS WIRING TO ANY APPLIANCE EQUIPPED WITH 24V CONTROLS NO POST-PURGE RELAY/TIMER ON DRAFT INDUCER

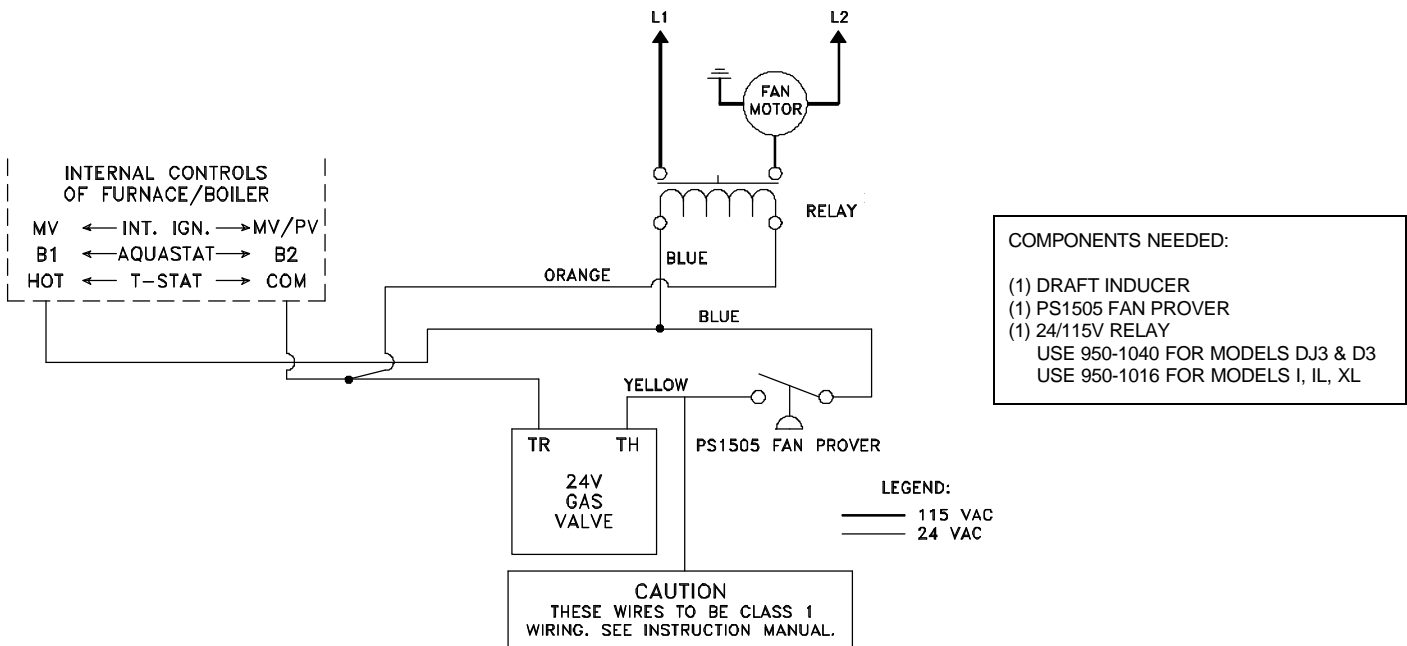

**GAS WIRING TO ANY APPLIANCE EQUIPPED WITH 24V CONTROLS
POST-PURGE RELAY/TIMER ON DRAFT INDUCER (DRAFT INDUCER MOTOR LESS THAN 4.4 AMPS)
MODELS I, IL, XL MUST USE 950-0483 ISOLATION RELAY**

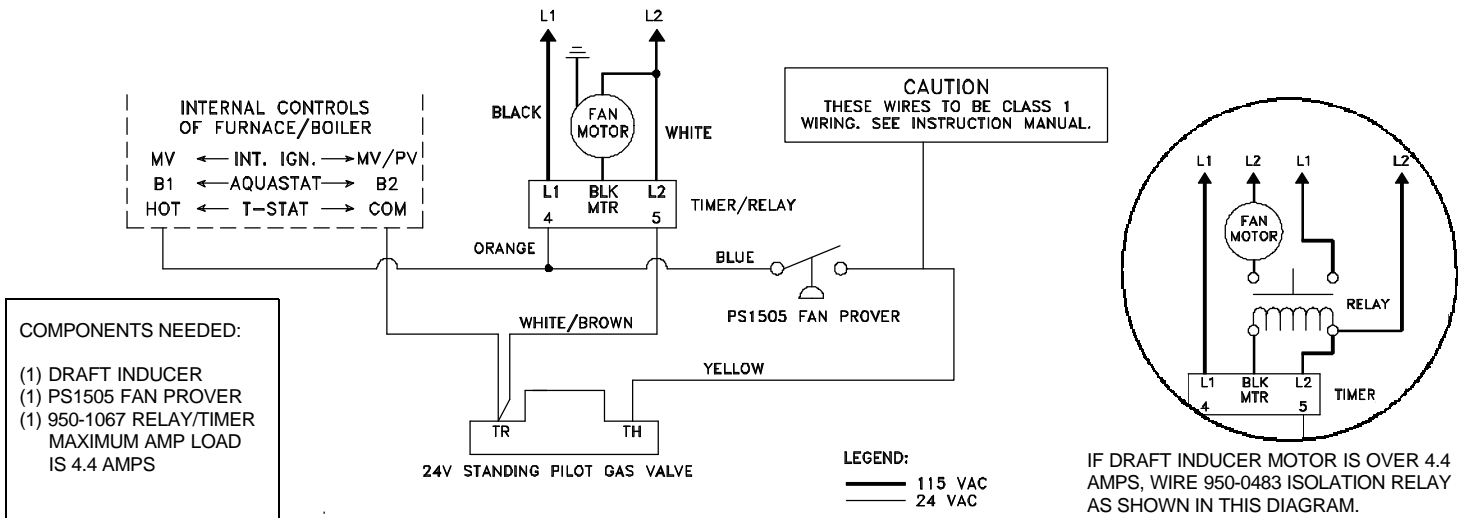

**GAS WIRING TO ANY APPLIANCE WITH MILLIVOLT CONTROLS
REQUIRES POST-PURGE RELAY/TIMER ON DRAFT INDUCER (DRAFT INDUCER MOTOR LESS THAN 4.4 AMPS)
MODELS I, IL, XL MUST USE 950-0483 ISOLATION RELAY**

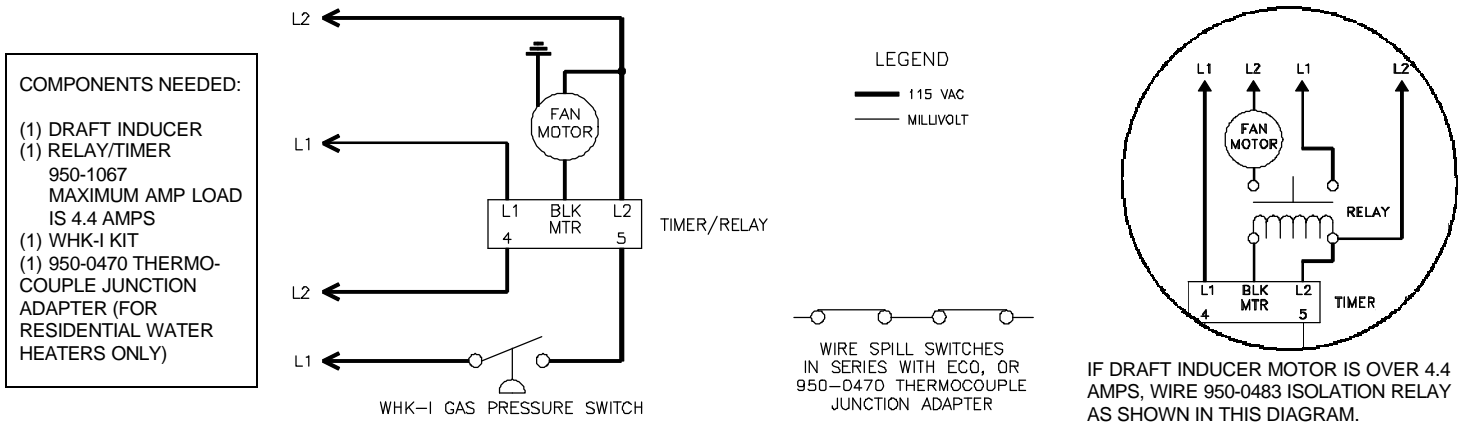

**DRAFT INDUCER CONNECTED WITH UP TO 4 24V GAS APPLIANCES WITH THE MAC-4 CONTROL
(MODEL HD REQUIRES USE OF MOTOR ISOLATION RELAY / CONTACTOR, SEE TOP OF PAGE 7)**

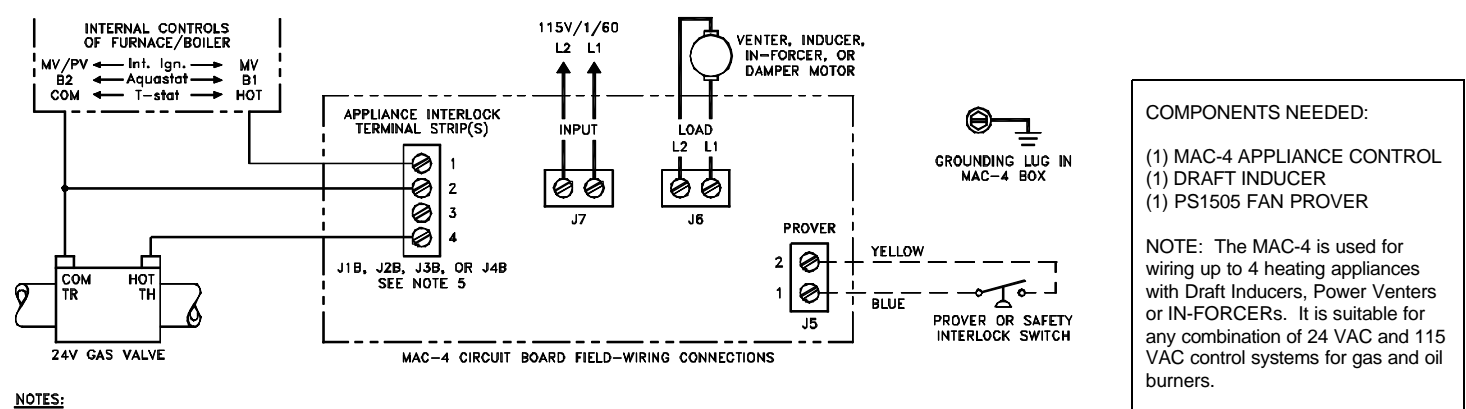

- NOTES:**
1. THE DISCONNECT MEANS AND CIRCUIT PROTECTION ARE TO BE PROVIDED BY THE INSTALLER OF THIS DEVICE.
 2. 1 H.P. MAX LOAD TO (J6) LOAD TERMINALS.
 3. 115 VAC INPUT L1 & L2 (J7) MUST BE GREATER THAN OR EQUAL TO "LOAD" (J6) PLUS 1/10 AMP.
 4. DO NOT SUPPLY POWER TO PROVER (J5) OR MAC-4 WILL BE DAMAGED.
 5. APPLIANCE 3 AND 4 (J3B & J4B) TERMINAL POSITIONS 1-4 ARE IN REVERSE ORDER FROM APPLIANCE 1 AND 2 (J1B & J2B) TERMINAL POSITIONS.
 6. 1 H.P. MAX LOAD TO APPLIANCE TERMINALS 3 AND 4 (J1B, J2B, J3B, J4B).

DRAFT INDUCER CONNECTED WITH UP TO 4 24V GAS APPLIANCES WITH THE MAC-4 CONTROL

(DRAFT INDUCER MOTOR LOAD GREATER THAN 1 H.P.)

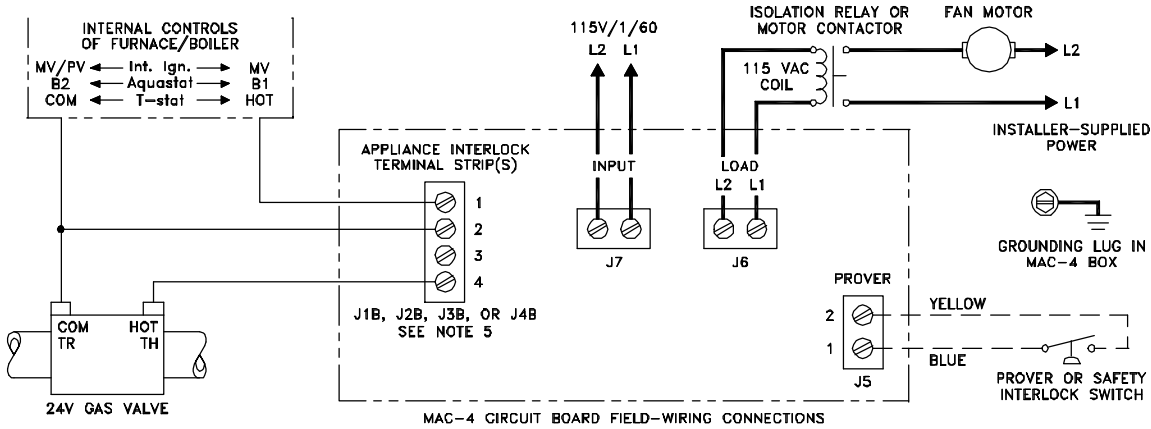

COMPONENTS NEEDED:

- (1) MAC-4 APPLIANCE CONTROL
- (1) DRAFT INDUCER
- (1) PS1505 FAN PROVER
- (1) ISOLATION RELAY/CONTACTOR

NOTE: The MAC-4 is used for wiring up to 4 heating appliances with Draft Inducers, Power Venters or IN-FORCERS. It is suitable for any combination of 24 VAC and 115 VAC control systems for gas and oil burners.

NOTES:

1. THE DISCONNECT MEANS AND CIRCUIT PROTECTION ARE TO BE PROVIDED BY THE INSTALLER OF THIS DEVICE.
2. 1 H.P. MAX LOAD TO (J6) LOAD TERMINALS.
3. 115 VAC INPUT L1 & L2 (J7) MUST BE GREATER THAN OR EQUAL TO "LOAD" (J6) PLUS 1/10 AMP.
4. DO NOT SUPPLY POWER TO PROVER (J5) OR MAC-4 WILL BE DAMAGED.
5. APPLIANCE 3 AND 4 (J3B & J4B) TERMINAL POSITIONS 1-4 ARE IN REVERSE ORDER FROM APPLIANCE 1 AND 2 (J1B & J2B) TERMINAL POSITIONS.
6. 1 H.P. MAX LOAD TO APPLIANCE TERMINALS 3 AND 4 (J1B, J2B, J3B, J4B).

LEGEND:

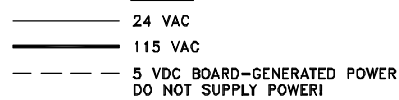

SCHEMATIC 4842104

MULTIPLE DRAFT INDUCERS, POWER VENTERS OR IN-FORCERS CONNECTED WITH UP TO 4 24V GAS APPLIANCES (IF INDIVIDUAL OR COMBINED MOTOR LOAD IS OVER 1 H.P. ISOLATION RELAY(S) WILL HAVE TO BE ADDED, SEE ABOVE)

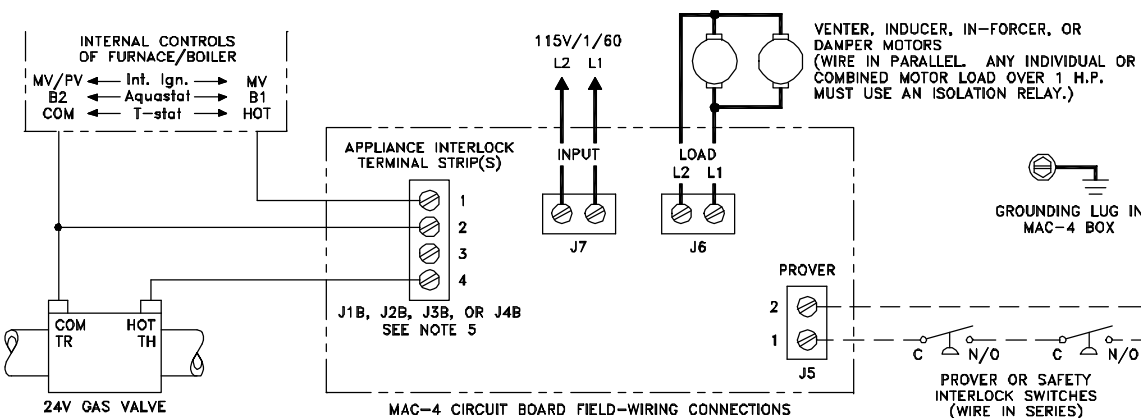

COMPONENTS NEEDED:

- (1) MAC-4 APPLIANCE CONTROL
- DRAFT INDUCER(S)
- PS1505 FAN PROVER(S)
- MOTOR ISOLATION RELAY / CONTACTOR(S) IF OVER 1 H.P.

NOTE: The MAC-4 is used for wiring up to 4 heating appliances with Draft Inducers, Power Venters or IN-FORCERS. It is suitable for any combination of 24 VAC and 115 VAC control systems for gas and oil burners. Wire Fan Prover(s) or Limit(s) in Series with Prover terminal block. Do not supply voltage to Prover terminal block!

NOTES:

1. THE DISCONNECT MEANS AND CIRCUIT PROTECTION ARE TO BE PROVIDED BY THE INSTALLER OF THIS DEVICE.
2. 1 H.P. MAX LOAD TO (J6) LOAD TERMINALS.
3. 115 VAC INPUT L1 & L2 (J7) MUST BE GREATER THAN OR EQUAL TO "LOAD" (J6) PLUS 1/10 AMP.
4. DO NOT SUPPLY POWER TO PROVER (J5) OR MAC-4 WILL BE DAMAGED.
5. APPLIANCE 3 AND 4 (J3B & J4B) TERMINAL POSITIONS 1-4 ARE IN REVERSE ORDER FROM APPLIANCE 1 AND 2 (J1B & J2B) TERMINAL POSITIONS.
6. 1 H.P. MAX LOAD TO APPLIANCE TERMINALS 3 AND 4 (J1B, J2B, J3B, J4B).

LEGEND:

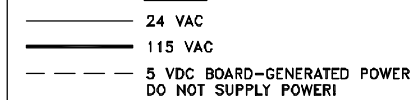

SCHEMATIC 4842108

**DRAFT INDUCER CONNECTED WITH UP TO 4 115V GAS APPLIANCES WITH THE MAC-4 CONTROL
(IF MOTOR LOAD IS GREATER THAN 1 H.P. AN ISOLATION RELAY WILL HAVE TO BE ADDED, SEE TOP OF PAGE 7)**

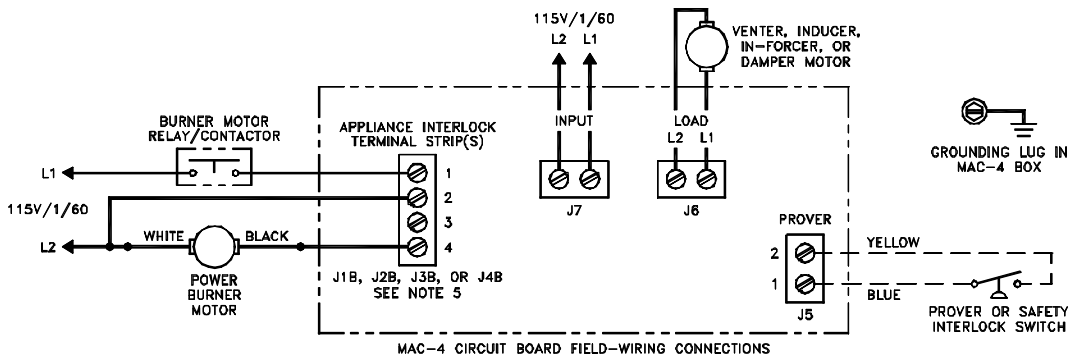

COMPONENTS NEEDED:

- (1) MAC-4 APPLIANCE CONTROL
- (1) DRAFT INDUCER
- (1) PS1505 FAN PROVER

NOTE: The MAC-4 is used for wiring up to 4 heating appliances with Draft Inducers, Power Venters or IN-FORCERS. It is suitable for any combination of 24 VAC and 115 VAC control systems for gas and oil burners.

NOTES:

1. THE DISCONNECT MEANS AND CIRCUIT PROTECTION ARE TO BE PROVIDED BY THE INSTALLER OF THIS DEVICE.
2. 1 H.P. MAX LOAD TO (J6) LOAD TERMINALS.
3. 115 VAC INPUT L1 & L2 (J7) MUST BE GREATER THAN OR EQUAL TO "LOAD" (J6) PLUS 1/10 AMP.
4. DO NOT SUPPLY POWER TO PROVER (J5) OR MAC-4 WILL BE DAMAGED.
5. APPLIANCE 3 AND 4 (J3B & J4B) TERMINAL POSITIONS 1-4 ARE IN REVERSE ORDER FROM APPLIANCE 1 AND 2 (J1B & J2B) TERMINAL POSITIONS.
6. 1 H.P. MAX LOAD TO APPLIANCE TERMINALS 3 AND 4 (J1B, J2B, J3B, J4B).

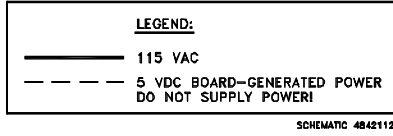

**DRAFT INDUCER CONNECTED TO OIL BURNER WITH R8184G CONTROLS
(DRAFT INDUCER MOTOR LESS THAN 4.4 AMPS) MODELS I, IL, XL MUST USE 950-0483 ISOLATION RELAY**

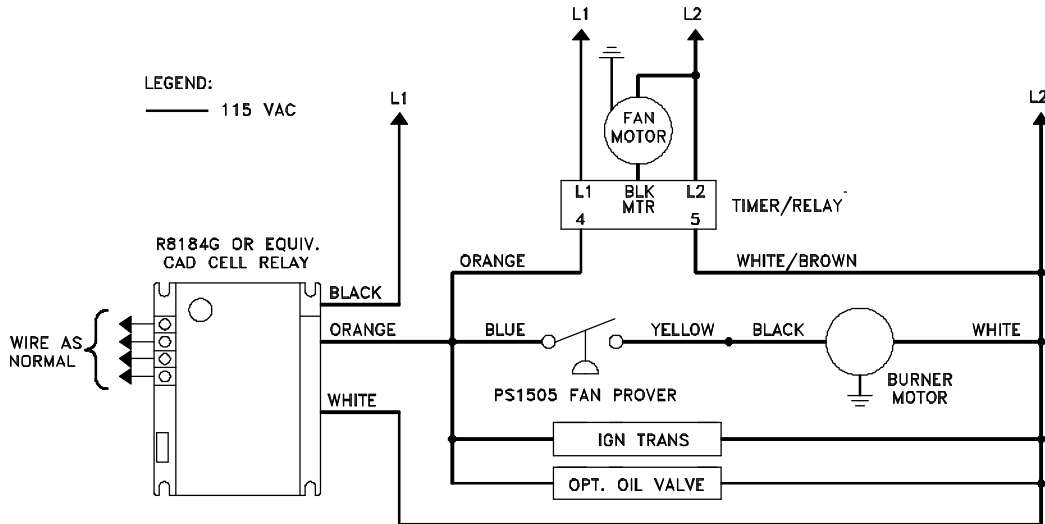

COMPONENTS NEEDED:

- (1) DRAFT INDUCER
- (1) PS1505 FAN PROVER
- (1) 950-1067 RELAY/TIMER
MAXIMUM AMP LOAD IS 4.4 AMPS

USE DIAGRAM BELOW IF DRAFT INDUCER MOTOR IS GREATER THAN 4.4 AMPS

**DRAFT INDUCER CONNECTED TO OIL BURNER WITH R8184G CONTROLS
(DRAFT INDUCER MOTOR GREATER THAN 4.4 AMPS) INCLUDES MODELS I, IL, XL**

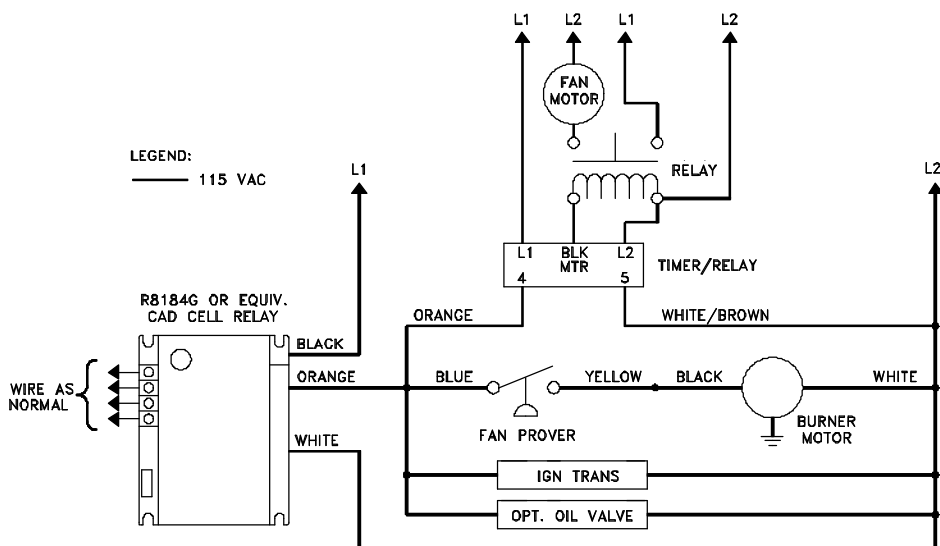

COMPONENTS NEEDED:

- (1) DRAFT INDUCER
- (1) PS1505 FAN PROVER
- (1) 950-1067 RELAY/TIMER
MAXIMUM AMP LOAD IS 4.4 AMPS
- (1) 950-0483 115/115V RELAY

DRAFT INDUCER CONNECTED WITH UP TO 4 OIL FIRED BURNERS WITH THE MAC-4 AND A 950-1067 POST-PURGE RELAY/TIMER (VENTER MOTOR LESS THAN 4.4 AMPS) MODELS I, IL, XL MUST USE 950-0483 ISOLATION RELAY

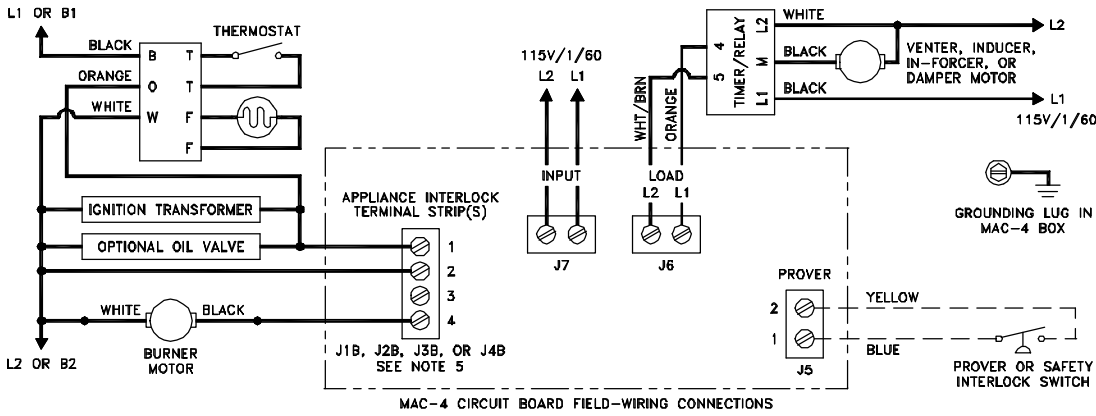

COMPONENTS NEEDED:

- (1) DRAFT INDUCER
- (1) PS1505 FAN PROVER
- (1) 950-1067 RELAY/TIMER
- MAXIMUM AMP LOAD IS 4.4 AMPS

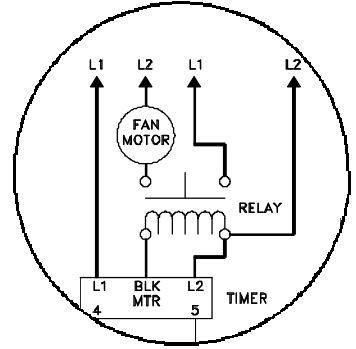

IF DRAFT INDUCER MOTOR IS OVER 4.4 AMPS, WIRE 950-0483 ISOLATION RELAY AS SHOWN IN THIS DIAGRAM.

- NOTES:**
1. THE DISCONNECT MEANS AND CIRCUIT PROTECTION ARE TO BE PROVIDED BY THE INSTALLER OF THIS DEVICE.
 2. 1 H.P. MAX LOAD TO (J6) LOAD TERMINALS.
 3. 115 VAC INPUT L1 & L2 (J7) MUST BE GREATER THAN OR EQUAL TO "LOAD" (J6) PLUS 1/10 AMP.
 4. DO NOT SUPPLY POWER TO PROVER (J5) OR MAC-4 WILL BE DAMAGED.
 5. APPLIANCE 3 AND 4 (J3B & J4B) TERMINAL POSITIONS 1-4 ARE IN REVERSE ORDER FROM APPLIANCE 1 AND 2 (J1B & J2B) TERMINAL POSITIONS.
 6. 1 H.P. MAX LOAD TO APPLIANCE TERMINALS 3 AND 4 (J1B, J2B, J3B, J4B).

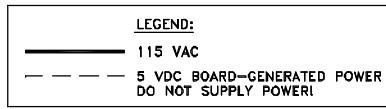

SCHEMATIC 4842105

MULTIPLE DRAFT INDUCERS, POWER VENTERS OR IN-FORCERS CONNECTED WITH UP TO 4 115V OIL FIRED BURNERS (IF INDIVIDUAL OR COMBINED MOTOR LOAD IS OVER 1 H.P. ISOLATION RELAY(S) WILL HAVE TO BE ADDED)

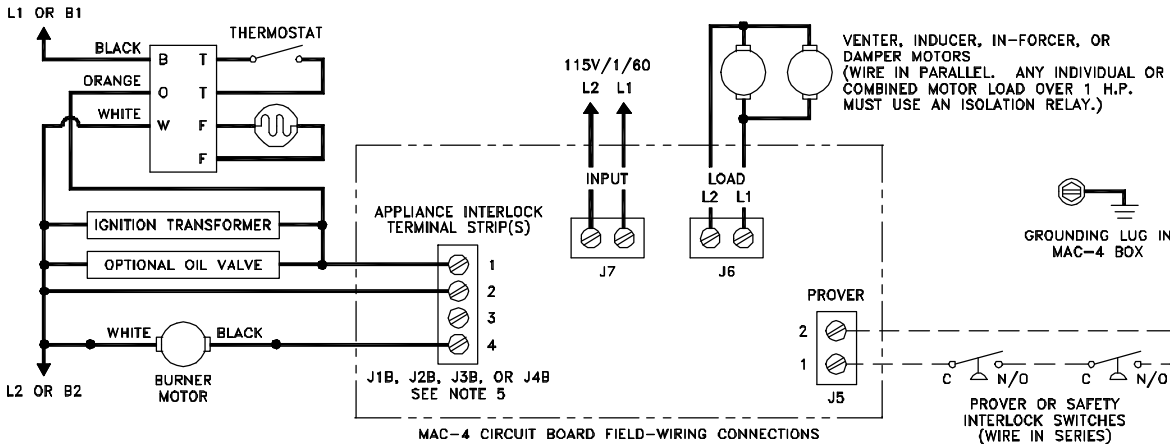

COMPONENTS NEEDED:

- (1) MAC-4 APPLIANCE CONTROL
- DRAFT INDUCER(S)
- PS1505 FAN PROVER(S)
- MOTOR ISOLATION RELAY / CONTACTOR(S) IF OVER 1 H.P.

NOTE: The MAC-4 is used for wiring up to 4 heating appliances with Draft Inducers, Power Venters or IN-FORCERS. It is suitable for any combination of 24 VAC and 115 VAC control systems for gas and oil burners. Wire Fan Prover(s) or Limit(s) in Series with Prover terminal block. Do not supply voltage to Prover terminal block!

- NOTES:**
1. THE DISCONNECT MEANS AND CIRCUIT PROTECTION ARE TO BE PROVIDED BY THE INSTALLER OF THIS DEVICE.
 2. 1 H.P. MAX LOAD TO (J6) LOAD TERMINALS.
 3. 115 VAC INPUT L1 & L2 (J7) MUST BE GREATER THAN OR EQUAL TO "LOAD" (J6) PLUS 1/10 AMP.
 4. DO NOT SUPPLY POWER TO PROVER (J5) OR MAC-4 WILL BE DAMAGED.
 5. APPLIANCE 3 AND 4 (J3B & J4B) TERMINAL POSITIONS 1-4 ARE IN REVERSE ORDER FROM APPLIANCE 1 AND 2 (J1B & J2B) TERMINAL POSITIONS.
 6. 1 H.P. MAX LOAD TO APPLIANCE TERMINALS 3 AND 4 (J1B, J2B, J3B, J4B).

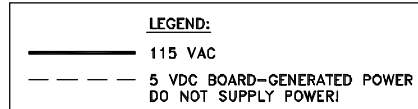

SCHEMATIC 4842109

OPERATION CIRCUIT CHECK

1. After all appliance wiring is complete, establish 115V power to the appliance and Draft Inducer with the appliance thermostat / aquastat not calling for heat. NOTE: If using a post-purge Relay/Timer, the Draft Inducer may operate when power is first established. Wait until the Draft Inducer shuts off before continuing.
2. Adjust the appliance thermostat/aquastat to call for heat. At this point, the Draft Inducer should start. After a slight delay, (up to 4 seconds), the appliance burner should fire after the PS1505 Fan Proving Switch proves draft. The delay is caused by the PS1505 Fan Proving Switch. If you are unable to detect a slight delay, contact Tjernlund Products, Inc. at 1-800-255-4208 for assistance.

DO NOT OPERATE THE APPLIANCE WITHOUT THE PS1505 PROVING SWITCH WIRED INTO THE THE EQUIPMENT CIRCUIT!

3. Adjust the appliance thermostat / aquastat so that no heat is required. At this point the Draft Inducer and appliance should shut off. **NOTE:** If using a P/N 950-1067 post-purge Relay/Timer, the Draft Inducer will continue to run for an adjustable amount of time after the appliance burner shuts off. See "Post Purge Relay/Timer Adjustment" below for post purge adjustment procedure.

P/N 950-1067 POST PURGE RELAY/TIMER ADJUSTMENT

1. Disrupt 115VAC power to the Draft Inducer.
2. The post purge Relay/Timer is marked adjustable delay control. The adjustment is made by turning the small slotted screw. Turn it counter clockwise to increase the delay, clockwise to decrease the delay. Caution: Use care when adjusting Relay/Timer, over-turning adjustment screw will damage Relay/Timer and void warranty. Nominal adjustment range is 1 to 10 minutes.

COMBUSTION AIR

Adequate combustion air is vital for proper combustion and for safe venting. Likewise, for proper Draft Inducer performance, adequate combustion air must be available to the appliance. Many installers assume adequate combustion air is present, especially in older structures. In some cases this is a false assumption, because many structures have been made "tight" due to weatherization. Size the combustion air opening(s) into the appliance room as outlined NFPA 54/NFPA 211. Tjernlund's IN-FORCER™ combustion air intake systems provide a convenient, interlocked way to supply combustion air to the utility room. When installing a Draft Inducer it is not necessary to supply any more combustion air than normally required when conventional venting.

SAFETY INTERLOCK / COMBUSTION AIR TEST

WARNING

The PS1505 Fan Proving Switch is designed to disable the appliance upon Draft Inducer failure only! It is not designed and cannot replace, regular vent system inspection, appliance servicing and combustion testing.

1. Close all doors and windows of the building. If the appliance is installed in a utility room or closet, close the entrance door to this room. Close fireplace dampers.
 2. Turn on all exhaust fans such as range hoods, bathroom exhausts, whole house fans and dryers to maximum speeds. Do not operate a fan used strictly for Summer exhausting.
 3. Following the appliance manufacturer's instructions, place the appliance in operation, set thermostat for continuous operation.
 4. Allow fans and appliance to operate for 5 minutes.
 5. Test for spillage at the appliance draft hood, draft control or draft diverter relief opening using the flame of a match, candle or smoke from a cigarette, cigar or pipe and determine the following:
 - A) The flame or smoke is being drawn into the draft hood, draft control or draft diverter.
 - B) The main burner is burning properly, i.e. no floating, lifting or flashback. Adjust the primary air shutter(s) and Draft Inducer Vari-Draft damper adjustment as required.
 - C) If the appliance is equipped with high and low flame controlling or flame modulation, check for proper main burner operation at low flame.
- If the draw of the flame or smoke appears to be excessive, follow the "Draft Control" procedure outlined below.
6. Sign and date these instructions to verify that the safety interlock / combustion air test was completed.

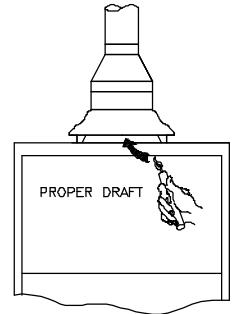

These instructions must remain on premises. SIGN: _____ DATE: _____

DRAFT CONTROL

The degree of the induced draft provided by the Auto-Draft inducer can be varied by the exclusive Vari-Draft Control. Moving the lever of the Vari-Draft while observing readings with a draft gauge will allow setting for maximum efficiency.

Oil burning installations and gas-fired units without a draft hood / diverter should include a barometric draft control. This should be adjusted to slightly open at maximum draft. The barometric control will then open further to regulate draft as external conditions change to lessen effect required by the inducer.

The Models D-3 and DJ-3 are shipped from the factory so that maximum draft is established when the unit is installed. If lesser draft is required, utilize the Vari-Draft sliding damper found in the installation packet. Sliding the Vari-Draft damper further into the pipe will lessen the draft produced by the inducer.

When a number of appliances must be served by a common vent, care must be taken in establishing proper connector rise and manifold size serving each appliance in the vent system. Consult the chapter on chimneys, gas vents and fireplace systems in the "Equipment Volume" of the [Ashrae Guide and Data Book](#) for specific requirements in a given application.

MAINTENANCE

Specific instructions cannot be made concerning frequency of lubrication. Normal usage will require oiling no more than twice a year. **No more than 3 drops of S.A.E. 20 oil should be used.** Oil holes or lances are provided at front and rear faces of motor. Units with sealed ball bearings will normally operate for years without repacking of bearings. **Models DJ-3 & D-3 require no oiling.**

Maladjusted and inefficient burner operation may cause soot and hard carbon buildup on inducer wheel. This can result in an unbalanced wheel and damage may occur to shaft and bearings, as well as reduce the efficiency of the inducer. Inspect inducer periodically and clean if necessary. Correct burner operation to cleanup fire.

MODEL HD ONLY

Belts should be checked and adjusted at least once a year. Replace worn belts immediately. When either belt needs replacement, a matched pair of new belts must be installed.

HOW TO OBTAIN SERVICE ASSISTANCE

1. If you have any questions about your Draft Inducer or if it requires adjustment, repair or routine maintenance, we suggest that you contact your installer, plumbing contractor or service agency.
2. If you require technical information contact Tjernlund Products, Inc. at 1-800-255-4208.

When contacting Tjernlund Products, Inc., please have the following information available:

1. Model number of the Draft Inducer
2. Name and address of installer and service agency
3. Date of original installation and dates any service work was performed
4. Details of the problem

LIMITED PARTS WARRANTY AND CLAIM PROCEDURE

Tjernlund Products, Inc. warrants the components of its products for one year from date of installation. This warranty covers defects in material and workmanship. This warranty does not cover normal maintenance, transportation or installation charges for replacement parts or any other service calls or repairs. Products that are tampered with, damaged, installed improperly, wired incorrectly or defective due to malfunctioning appliances are not covered under this warranty. This warranty DOES NOT cover the complete Draft Inducer if it is operable, except for the defective part.

Tjernlund Products, Inc. will issue credit to the original distributor or provide a free part to replace one that becomes defective during the one year warranty period. If the part is over 18 months old, proof of date of the installation in the form of the contractor sales / installation receipt is necessary to prove the unit has been in service for under one year. All receipts should include the date code of the Draft Inducer to ensure that the defective component corresponds with the complete unit. This will help preclude possible credit refusal.

After the faulty component is determined, return it to your Tjernlund distributor for replacement. Please include Draft Inducer date code component was taken from. The date code is located on the electrical box coverplate or back of motor mount plate. If Draft Inducer date code is older than 18 months you will need to provide a copy of the original installation receipt to your distributor. Credit or replacement will only be issued to a Tjernlund distributor after the defective part has been returned prepaid to Tjernlund.

REPLACEMENT PARTS

MODEL DJ-3

PART NUMBER	DESCRIPTION
950-3010	WHEEL KIT
950-3020	MOTOR KIT

MODEL D-3

PART NUMBER	DESCRIPTION
950-3012	WHEEL KIT
950-3022	MOTOR KIT

MODEL I

PART NUMBER	DESCRIPTION
950-4010	WHEEL KIT
950-4020	MOTOR KIT
950-0131	CANADIAN MOTOR KIT
950-4025	SHAFT EXT. KIT

MODEL IL

PART NUMBER	DESCRIPTION
950-5010	WHEEL KIT
950-4020	MOTOR KIT
950-0131	CANADIAN MOTOR KIT
950-4025	SHAFT EXT. KIT

MODEL XL

PART NUMBER	DESCRIPTION
950-6010	WHEEL KIT
950-1017	MOTOR KIT
950-6025	SHAFT EXT. KIT

MODEL HD

PART NUMBER	DESCRIPTION
950-1074	WHEEL KIT
950-0151	MOTOR KIT
950-0117	BELT KIT
950-0106	MOTOR SHEAVE KIT
950-0104	SHAFT SHEAVE KIT

TJERNLUND LIMITED ONE YEAR WARRANTY

Tjernlund Products, Inc. warrants to the original purchaser of this product that the product will be free from defects due to faulty material or workmanship for a period of (1) year from the date of original purchase or delivery to the original purchaser, whichever is earlier. Remedies under this warranty are limited to repairing or replacing, at our option, any product which shall, within the above stated warranty period, be returned to Tjernlund Products, Inc. at the address listed below, postage prepaid. THERE ARE NO WARRANTIES WHICH EXTEND BEYOND THE DESCRIPTION ON THE FACE HEREOF, AND TJERNLUND PRODUCTS, INC. EXPRESSLY DISCLAIMS LIABILITY FOR INCIDENTAL OR CONSEQUENTIAL DAMAGES ARISING FROM THE USE OF THIS PRODUCT. THIS WARRANTY IS IN LIEU OF ALL OTHER EXPRESS WARRANTIES AND NO AGENT IS AUTHORIZED TO ASSUME FOR US ANY LIABILITY ADDITIONAL TO THOSE SET FORTH IN THIS LIMITED WARRANTY. IMPLIED WARRANTIES ARE LIMITED TO THE STATED DURATION OF THIS LIMITED WARRANTY. Some states do not allow limitation on how long an implied warranty lasts, so that limitation may not apply to you. In addition, some states do not allow the exclusion or limitation of incidental or consequential damages, so that above limitation or exclusion may not apply to you. This warranty gives you specific legal rights and you may also have other rights which may vary from State to State. Send all inquiries regarding warranty work to Tjernlund Products, Inc. 1601 9th Street, White Bear Lake, MN 55110-6794. Phone (651) 426-2993 • (800) 255-4208 • Fax (651) 426-9547 or email us at fanmail@tjfans.com.