



SERVICE PARTS LIST

BULLETIN NO.
54-06-2147

SPECIFY CATALOG NO. AND SERIAL NO. WHEN ORDERING PARTS		REVISED BULLETIN	DATE
M18™ RADIUS™ LED COMPACT SITE LIGHT		54-06-2145	July 2018
CATALOG NO.	2145-20	STARTING SERIAL NO.	H48B
WIRING INSTRUCTION			

EXAMPLE:
Component Parts (Small #)
Are Included When Ordering
The Assembly (Large #).

★ = Part number change
from previous service
parts list.

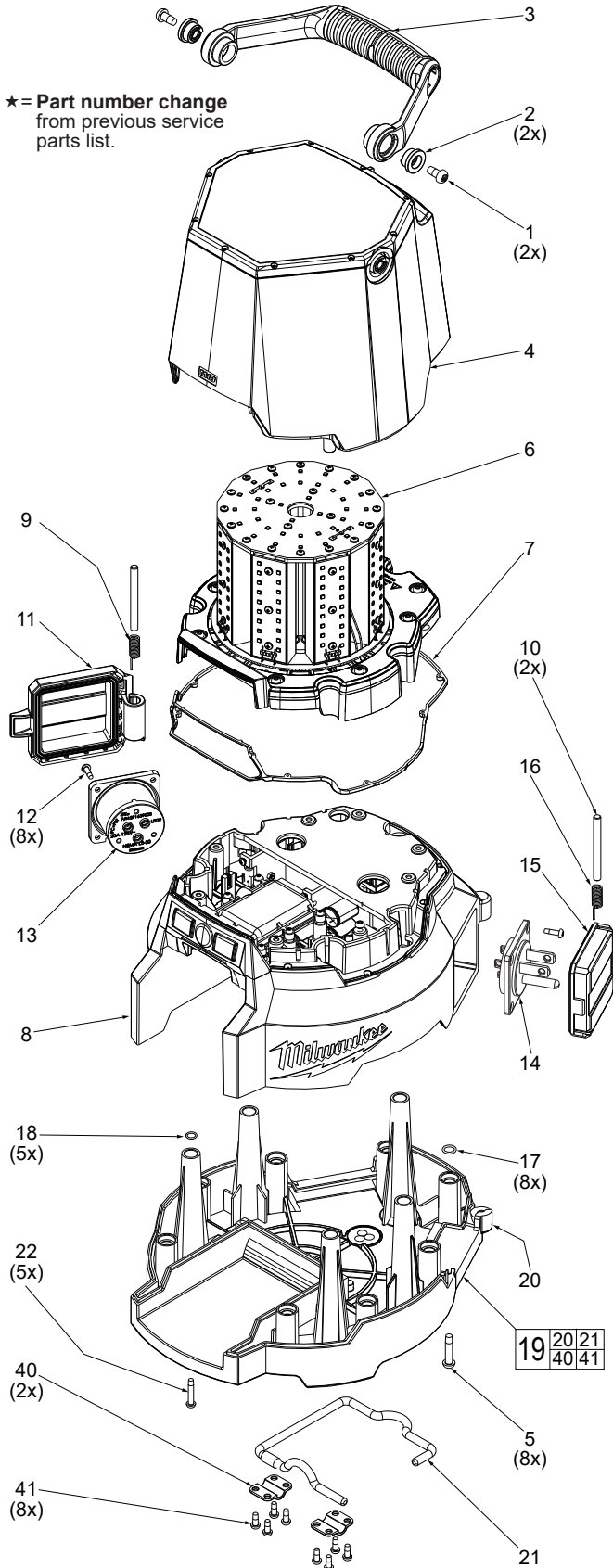

FIG.	PART NO.	DESCRIPTION OF PART	NO. REQ.
1	06-82-2005	M6 x 12 Screw	(2)
2	42-40-0165	Bushing	(2)
3	43-62-0095	Handle	(1)
4a	44-06-0005	Clear Lens Assy. w/ Screws	(1)
4b	44-06-0045	Diffused Lens Assy. w/ Screws	(1)
5	05-88-1360	M4 x 13.5 Screw	(8)
★ 6	23-28-0041	LED Console Assy.	(1)
7	43-40-0040	Sealing Ring	(1)
8	-----	Base	(1)
★ 9	40-50-7001	AC Outlet Cover Spring	(1)
★ 10	44-60-5001	Cover Pin	(2)
★ 11	23-33-0541	AC Outlet Cover	(1)
★ 12	05-81-1195	M3 x 12 Screw	(8)
13	23-33-0535	AC Outlet	(1)
14	23-33-0545	AC Inlet	(1)
★ 15	23-33-0073	AC Inlet Cover	(1)
★ 16	40-50-6001	AC Inlet Cover Spring	(1)
17	34-40-0340	O-Ring 1.5mm	(8)
18	34-40-0345	O-Ring 1.0mm	(5)
★ 19	14-38-4005	Bottom Cover Assy.	(1)
20	-----	Bottom Cover	(1)
★ 21	43-74-0006	Bottom Hook w/ Rubber Tube	(1)
22	05-81-1215	M4 x 22 Screw	(5)
23	12-20-2145	Service Nameplate (Not Shown)	(1)
24	42-44-0025	Security Cable (Not Shown)	(1)
40	-----	Hook Cover Plate	(2)
41	-----	M4 x 10mm Pan Hd. T-20 Screw	(8)

FIG. NOTES

23 A clean, dry surface is essential for proper performance for any adhesive system. The area intended for application of any adhesive label or nameplate must be prepared by cleaning with isopropyl alcohol. The solvent is to be applied with a clean, lint free applicator and the surface allowed to dry before applying the label or nameplate.