

PRODUCT INFORMATION PACKET



Model No: C4D17FK5L

Catalog No: 108022.00

..1HP..1750RPM.S56C.TEFC.90V...CONT.40C.1.0SF.RIGID C.C4D17FK5.....DC NEMA.....
SCR



Regal and Leeson are trademarks of Regal Beloit Corporation or one of its affiliated companies.

©2018 Regal Beloit Corporation, All Rights Reserved. MC017097E





Nameplate Specifications

Output HP	1 Hp	Output KW	0.75 kW
Voltage	90 V	Current	10.0 A
Speed	1750 rpm	Service Factor	1
Efficiency	83.7 %	Duty	Continuous
Insulation Class	F	Frame	S56C
Enclosure	Totally Enclosed Fan Cooled	Overload Protector	No
Ambient Temperature	40 °C	Drive End Bearing Size	6203
Opp Drive End Bearing Size	6203	UL	Recognized
CSA	Y	CE	N

Technical Specifications

Rotation	Reversible	Mounting	Rigid C base
Overall Length	14.82 in	Frame Length	7.47 in
Shaft Diameter	0.625 in	Shaft Extension	2.06 in
Outline Drawing	031879-108022		

This is an uncontrolled document once printed or downloaded and is subject to change without notice. Date Created: 10/15/2018

RBC PROPRIETARY AND CONFIDENTIAL INFORMATION
 This document is the property of REGAL BELOIT CORPORATION ("RBC") including its subsidiaries and divisions and contains proprietary information of RBC. This document is based on the express condition that neither it nor the information contained therein shall be disclosed to others without the express written consent of RBC, and that the information shall be used by the recipient only as approved expressly by RBC. This document shall be returned to RBC upon request. This document may be subject to certain restrictions under U.S. export control laws and regulations.

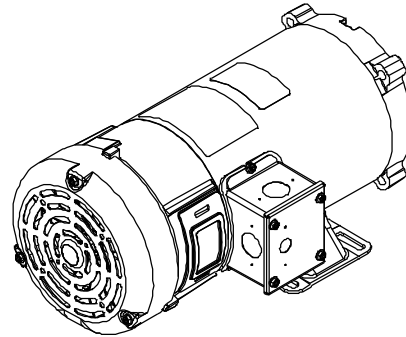
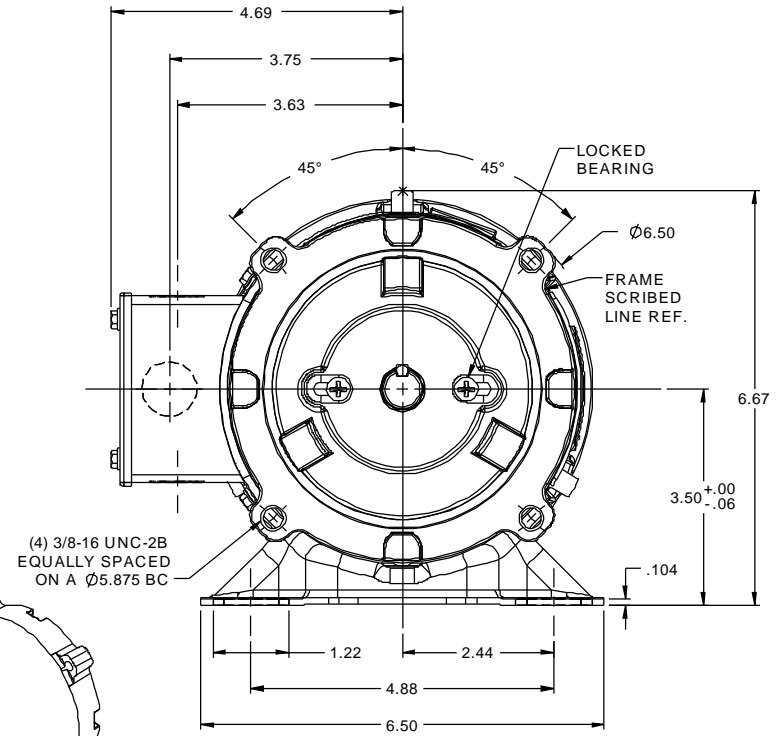
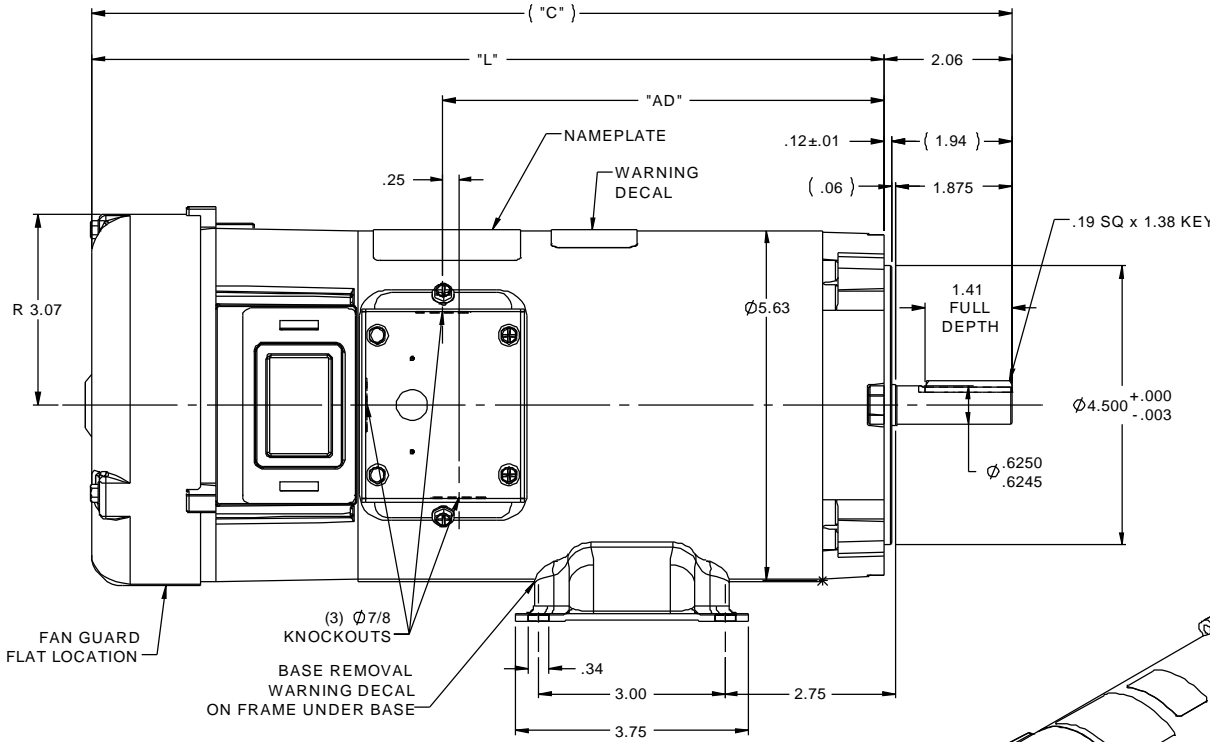

- NOTES:
 1) MAXIMUM FACE RUNOUT .004 T.I.R.
 2) MAXIMUM PILOT ECCENTRICITY .004 T.I.R.
 3) PERMISSIBLE SHAFT RUNOUT .002 T.I.R.
 4) GASKETS THROUGHOUT

109100.00	15.82	13.76	8.10	90	3/4	1140
109099.00	14.32	12.26	6.60	90	1/2	1140
109098.00	12.82	10.76	5.10	90	1/3	1140
108265.00	15.32	13.26	7.60	180	1 1/2	2500
108092.00	16.82	14.76	9.10	180	1 1/2	1750
108023.00	14.82	12.76	7.10	180	1	1750
108022.00	14.82	12.76	7.10	90	1	1750
108021.00	13.82	11.76	6.10	180	1	2500
108020.00	13.32	11.26	5.60	90	1	2500
108019.00	13.82	11.76	6.10	180	3/4	1750
108018.00	13.82	11.76	6.10	90	3/4	1750
108017.00	12.82	10.76	5.10	180	3/4	2500
108016.00	12.82	10.76	5.10	90	3/4	2500
108015.00	12.82	10.76	5.10	180	1/2	1750
108014.00	12.82	10.76	5.10	90	1/2	1750
CATALOG No.	"C"	"L"	"AD"	VOLTS	H.P.	RPM

06	CHANGED .06 & 1.94 DIMS TO REF., ISAAC 12-0984	IPG 1/30/2013	TOLERANCES UNLESS SPECIFIED							
05	ADDED NOTE ABOUT FAN GUARD LOCATION, ISAAC 09-4813	IPG 12/4/2009	DEC INCHES							
04	CAT. # 108092.00: "C" WAS 17.32, "L" WAS 15.26, "AD" WAS 9.60, ISAAC 09-1828	IPG 5/14/2009	X ±.1							
03	ADDED DATA FOR VARIOUS CAT. NUMBERS, COMPLETED	IPG 9/15/2008	XXX ±.005							
	TABLE		XXXX ±.0005							
NO	REVISION	BY & DATE	CHK LANG ±1/2°	FINISH						
	THIRD ANGLE PROJECTION		RFP	PREV						
			NETWORK FILE NAME	031879						
			SIZE	DRAWING NO	REV					
			B	031879	06					



ELECTRIC MOTORS
 GEARMOTORS
 AND DRIVES

DRAWN RWS 1/8/08
 CHK IPG 1/9/08
 APPR

TITLE OUTLINE
 48 FRAME DC - S56C MOUNT

SCALE 1:2
 REF 031189.00
 FMF 108022.75
 PAGE OF