

# ADJUSTABLE STEEL GANTRY CRANE - AHS-2-10-12

APPROX WEIGHT: 683.68 lbs.  
 DOES NOT INCLUDE WEIGHT OF POWER OR PACKAGING!!!

\*\*\* ANY ADDITIONS, DELETIONS, OR OMISSIONS MUST BE CORRECTED ON THIS DRAWING AS THIS DRAWING WILL BE CONSIDERED ALL INCLUSIVE \*\*\*

ALL GRAPHICS PROVIDED ARE FOR REFERENCE ONLY. IF CERTAIN DIMENSIONS ARE CRITICAL PLEASE VERIFY THOSE DIMENSIONS WITH YOUR SALESPERSON

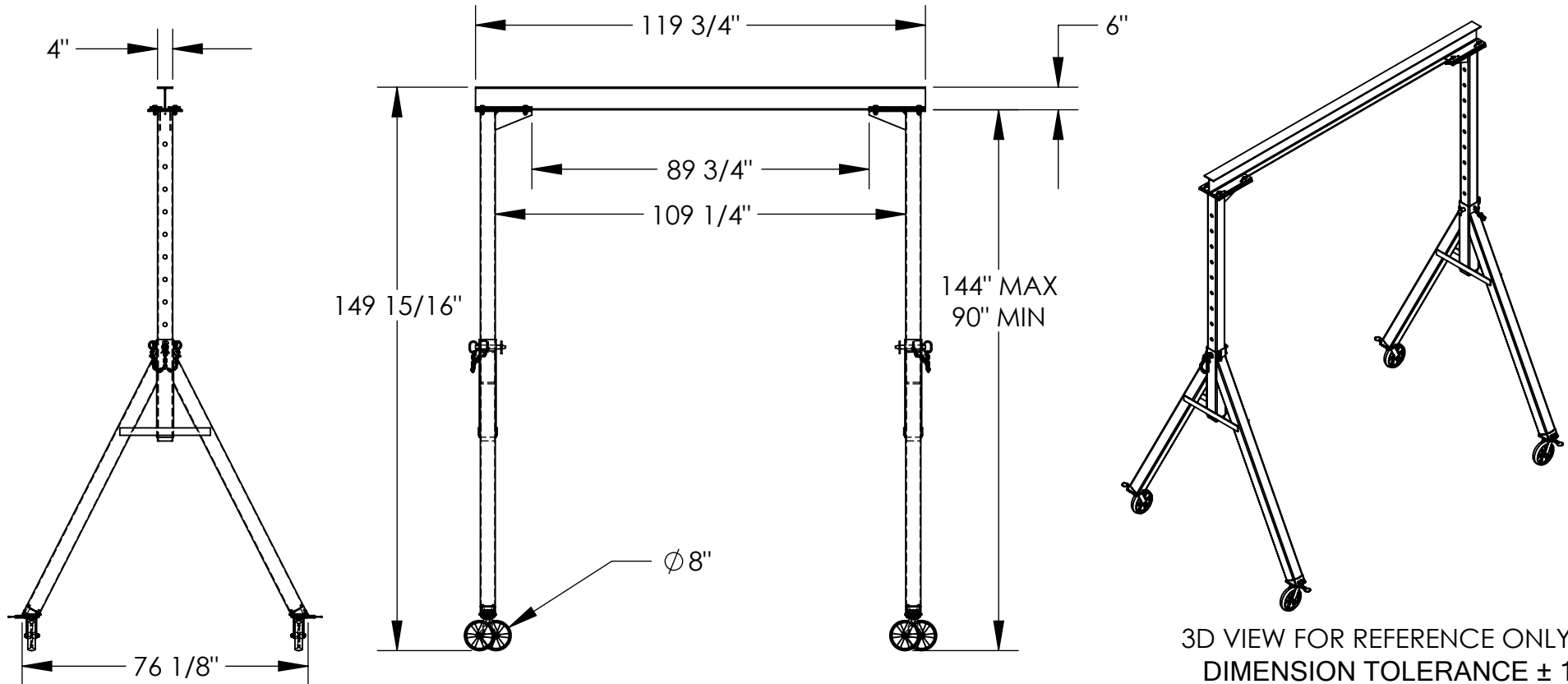

3D VIEW FOR REFERENCE ONLY  
 DIMENSION TOLERANCE ± 1/4"

## STANDARD FEATURES

- MODEL NUMBER IS AHS-2-10-12
- CAPACITY IS 2,000 LBS.
- BASE WIDTH IS 76 1/8"
- MAX OVERALL HEIGHT IS 149 15/16"
- I-BEAM HEIGHT IS 6"
- I-BEAM FLANGE WIDTH IS 4"
- OVERALL I-BEAM LENGTH IS 119 3/4"
- USABLE I-BEAM LENGTH IS 89 3/4"
- ADJUSTABLE UNDER I-BEAM HEIGHT
  - 144" MAX
  - 90" MIN
- HEIGHT IS ADJUSTABLE IN 6" INCREMENTS
- CASTERS: (4) Ø8" X 2" WIDE GLASS FILLED NYLON SWIVEL CASTERS WITH FOUR LOCKING POSITIONS
- DURABLE LIQUID PAINT BLUE FINISH

## SPECIAL FEATURES

NONE

APPROVAL

I, THE UNDERSIGNED, AGREE THAT THE PRODUCT AS REPRESENTED SATISFIES DESIGN AND DIMENSION REQUIREMENTS. I ALSO ACKNOWLEDGE MY DUTY TO CONFIRM PRODUCT AND INSTALLATION COMPLIANCE WITH ALL APPLICABLE FEDERAL, STATE AND LOCAL REGULATIONS AND STANDARDS.

**UNITS REQUIRING APPROVAL DRAWINGS OR MODIFIED ARE NON-RETURNABLE**

As drawn       As marked

Signed: \_\_\_\_\_ Date: \_\_\_\_\_

Printed Name: \_\_\_\_\_

LEAD TIME WILL START UPON RECEIPT OF SIGNED APPROVAL DRAWING

DISTRIBUTOR'S NAME:		P.O.#
VESTIL MANUFACTURING		X
DRAWN BY: ND	DATE: 09/30/09	W.O.#
REFERENCE: X	SCALE: 1:42	X
QUOTED LEAD TIME: X	QUOTE #	SALES: X
	X	FILE NAME:
		28-007-067