

# Assembly Instruction

## Part List

48J082 & 48J083 & 48J084

P/NO.	Description	Quantity
A	Pallet Dolly	1
B	Swivel Caster	4
C	Screw	16
D	Washer	16
E	Spring Washer	16
F	Nut	16

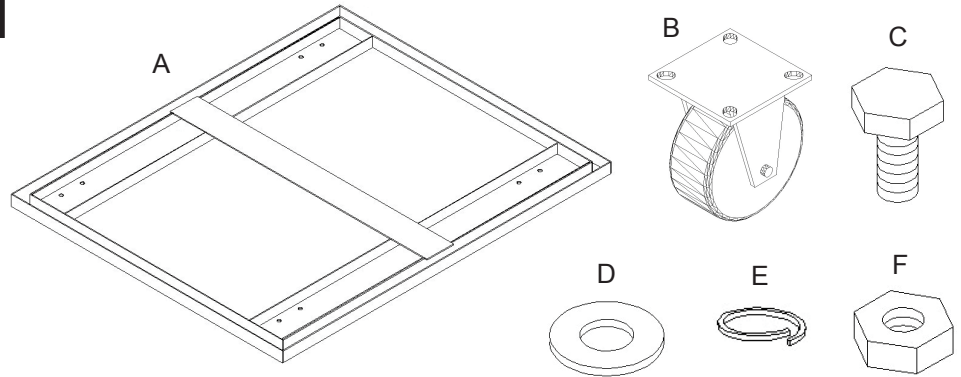

Step 1. Place the Swivel Caster (B) on the back of Pallet Dolly (A), and secure it with Screws (C) & Washers (D) & Spring Washers (E) and Nuts (F). Ready to use.

