



TECHNICAL CONCEPTS

MICROBURST® 3000 BATTERY-FREE DISPENSING SYSTEMS

Microburst® 3000 offers an effective air-freshening system that is now better and safer for the environment.

Features and Benefits:

- LumeCel™ Rechargeable Energy System: Rechargeable energy cells that are made from fully recyclable nickel metal hydride technology. Super efficient, they store energy from light (both artificial and natural), providing internal electrical power at nearly 100% efficiency. Easy to use and ready out of the box and guaranteed to run for at least 15 years.
- All refills contain Microtrans®, a true odor neutralizer, which is paired with the industry's highest quality fragrances to effectively eliminate "unavoidable odors" in commercial washrooms.
- Saves time and money: Staff will no longer need to purchase, store, replace and dispose of batteries. LumeCel is also virtually maintenance free, reducing the potential of workplace mishaps or accidents.
- Converting your existing Microburst 3000 Air Care System to LumeCel's revolutionary green technology is quick and easy. Simply remove the existing Microburst 3000 front cover, and replace with a LumeCel retrofit cover, which includes solar panels and the rechargeable energy cell.

Certifications:

-  The Green Dot signifies that the manufacturer of the product contributes to the cost of recovery and recycling.
-  The universal recycling symbol is an internationally recognized symbol used to designate recyclable materials.
-  The CE mark is the manufacturer's declaration that the product meets the requirements of the applicable EC directives.
-  Directive on Waste Electrical and Electronic Equipment (WEEE). The WEEE symbol, indicates a separate collection for WEEE- Waste of electrical and electronic equipment, consists of the crossed-out wheeled bin, as shown.

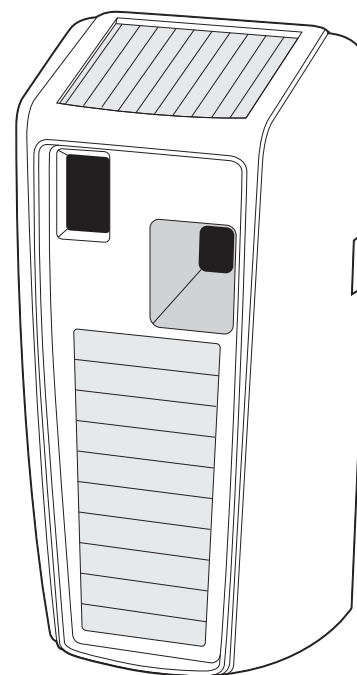
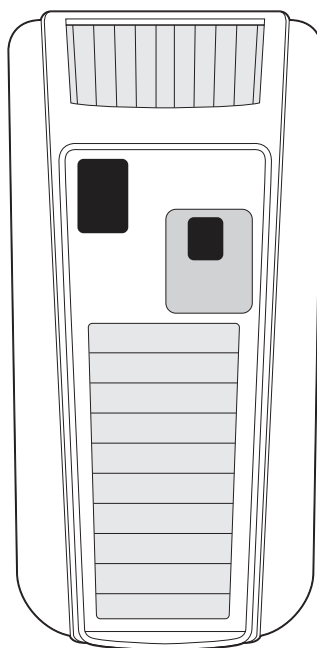

Microburst® 3000 with LumeCel™ Technology

DESCRIPTION	RETRO-FIT COVER	DISPENSER
Color	Black, white, chrome	Black, white, chrome
Product weight (lbs)	.430	.821
Product weight w/ packaging (lbs)	.709	1.100
Ship w/t/ ctn (lb)	7.8	5.4
Product dimensions (in)	5 x 4.75 x 8	5 x 4.75 x 8
Carton dimensions (in)	15.8 x 10.3 x 9.3	15.8 x 10.3 x 9.3
Pack Size	6	6

MICROBURST® 3000 GOING FROM OLD TO NEW

Retrofitting current dispenser:

Step 1: Remove the 'C' batteries from old dispenser

Step 2: Unhinge the old cover by pressing tab as shown

Step 3: Remove cover by lifting the left and right sides of the dispenser cover off placement tabs.

Step 4: Insert the LumeCel rechargeable energy cell

Step 5: Snap on the new cover

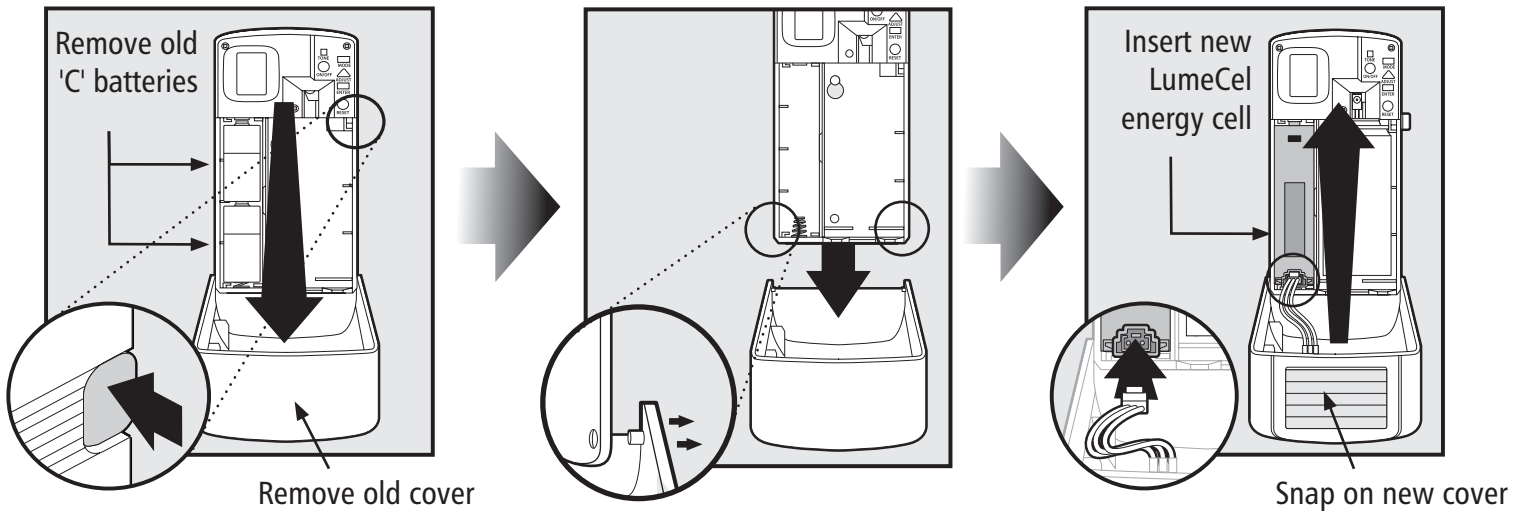

WHERE TO INSTALL

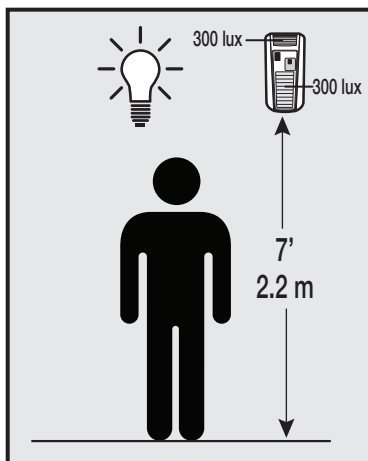

LUX Level must be 300 or more.

IDEAL ENVIRONMENTS

Works well in all washrooms, but especially recommended for use in:

- Foodservice
- Property Management
- Healthcare

Other suggested environments include:

- Higher Education
- K-12
- Manufacturing
- Entertainment Venues
- Retail and Service Transportation

08/15 | RCP1009
©2015 Rubbermaid Commercial Products LLC
3125 Valley Avenue, Winchester, VA 22601

To see our complete range of product solutions visit our online catalog at
rubbermaidcommercial.com



TECHNICAL CONCEPTS