



**FEDERAL SIGNAL**

Safety and Security Systems / **Industrial**

## **Global Series Model G-STR Strobe Beacon For Use in Hazardous Locations**



Ex d Surface Mount



Ex de Surface Mount

---

## ***Installation and Maintenance Instructions***

## Limited Warranty

This product is subject to and covered by a limited warranty, a copy of which can be found at [www.fedsig.com/SSG-Warranty](http://www.fedsig.com/SSG-Warranty). A copy of this limited warranty can also be obtained by written request to Federal Signal Corporation, 2645 Federal Signal Drive, University Park, IL 60484, email to [info@fedsig.com](mailto:info@fedsig.com) or call +1 708-534-3400.

This limited warranty is in lieu of all other warranties, express or implied, contractual or statutory, including, but not limited to the warranty of merchantability, warranty of fitness for a particular purpose and any warranty against failure of its essential purpose.



**FEDERAL SIGNAL**

Safety and Security Systems / Industrial

### Industrial Systems

2645 Federal Signal Drive • University Park, IL 60484-3167

Tel: 708-534-4756 • 877-289-3246 • Fax: 708-534-4852

Email: [elp@federalsignal.com](mailto:elp@federalsignal.com) • [www.federalsignal-indust.com](http://www.federalsignal-indust.com)

---

## Contents

<b>Safety Messages to Installers and Users .....</b>	<b>5</b>
<b>Certification.....</b>	<b>6</b>
<b>Unpacking the Beacon.....</b>	<b>7</b>
<b>Creating Combination Fixtures in the Field.....</b>	<b>8</b>
<b>Mounting the Beacon.....</b>	<b>9</b>
Mounting the Surface-Mount Ex d Beacon .....	9
Mounting the Ex de Surface-Mount Beacon.....	11
<b>Safety Messages for Wiring.....</b>	<b>13</b>
<b>Preparing to Wire the Ex d Flameproof Models.....</b>	<b>14</b>
<b>Wiring the Ex d Models .....</b>	<b>15</b>
24 Vdc Models .....	15
120 Vac and 220-240 Vac Models.....	15
<b>Preparing to Wire the Ex de Increased Safety Models.....</b>	<b>16</b>
<b>Wiring the Ex de Models .....</b>	<b>17</b>
24 Vdc Model.....	18
120 Vac or 220-240 Vac Ex de Models.....	18
<b>Safety Messages to Maintenance Personnel.....</b>	<b>19</b>
<b>Maintaining the Beacon .....</b>	<b>20</b>
Cleaning the Enclosure .....	20
Replacing the Strobe Tube .....	20
Lubricating the Threaded Joints.....	22
<b>Ordering Accessories and Replacement Parts .....</b>	<b>22</b>
<b>Getting Repair Service or Technical Assistance .....</b>	<b>25</b>
<b>Returning the Product for Credit .....</b>	<b>25</b>

**Tables**

**Table 1** Replacement parts ..... 23

**Table 2** Accessories ..... 23

**Table 3** Choosing cable-entry devices for Equipment  
in Potentially Explosive Atmospheres..... 23

**Figures**

**Figure 1** Beacon and sounder combination fixture ..... 8

**Figure 2** Front view of Ex d beacon ..... 9

**Figure 3** Side view of Ex d beacon ..... 10

**Figure 4** Front view of Ex de surface mount ..... 11

**Figure 5** Side view of Ex de surface mount ..... 12

**Figure 6** IN/OUT PCB connections for Ex d 24 Vdc ..... 15

**Figure 7** IN/OUT PCB connections for  
Ex d 120 Vac and 220-240 Vac ..... 16

**Figure 8** Connections for DC or AC Ex de beacons ..... 18

## **Safety Messages to Installers and Users**

### **⚠ WARNING**

It is important to follow all instructions shipped with this product. This beacon is to be installed by a trained electrician who is thoroughly familiar with and will follow all applicable national and local codes in the country of use.

This beacon should be considered a part of the warning system and not the entire warning system.

The selection of the mounting location for the beacon, its controls and the routing of the wiring are to be accomplished under the direction of the facilities engineer and the safety engineer. In addition, listed below are some other important safety instructions and precautions you should follow:

- Read and understand all instructions before installing or operating this equipment.
- To avoid electrical shock hazards, do not connect wires when power is applied. Failure to observe this warning may lead to serious injury or death.
- Never alter the unit in any manner. Safety in hazardous locations may be endangered if additional openings or other alterations are made in units specifically designed for use in these locations.
- Do not connect this beacon to the system when power is on.
- After installation, ensure that all threaded joints are properly tightened.
- Keep the unit tightly closed when in operation.
- After installation, test the beacon system to ensure that it is operating properly.
- After testing is complete, provide a copy of this instruction sheet to all personnel.
- Establish a procedure to routinely check the beacon system for proper activation and operation.

## ***Installation and Maintenance Instructions***

---

- Brass inserts have the potential to store charge when they are not plugged. Consideration should be taken to prevent these from becoming a sparking hazard.
- The lens guard has the potential to store charge. Consideration should be taken to prevent this from becoming a sparking hazard.
- Maximum flash frequency is 60 FPM.
- This equipment is suitable for use in Class I, Division 2, Groups A, B, C, D; Class II, Division 2, Groups F and G; Class III or non-hazardous locations only.
- **WARNING: EXPLOSION HAZARD** — Do not disconnect the equipment unless power has been switched off or unless the area is known to be non-hazardous.
- **WARNING: EXPLOSION HAZARD**—Do not remove or replace the fuse when energized.

Failure to follow all safety precautions and instructions may result in property damage, serious injury, or death.

### **Certification**

Certificate Nos.: ATEX Cert No.: Baseefa15ATEX0154X  
IECEX Cert No.: IECEX BAS 15.0103X

ATEX coding:  II 2 G D

Ex db IIC T3 Gb

Protection: Ex db e IIC T3 Gb  
(21 joule) Ex tb IIIC T200°C Db IP66  
(Tamb= -55°C to +70°C)

Protection: Ex db IIC T4 Gb  
(15 joule)\* Ex db e IIC T4 Gb  
Ex tb IIIC T135°C Db IP66  
(Tamb= -55°C to +70°C)

\*Model#s are GSTR-xxx-x-x-15J. These models are not UL/cUL listed.

EN60079-0: 2012 + A11:2013, EN60079-1: 2014

EN60079-7: 2007, EN60079-31:2014,

IEC60079-0: 6<sup>th</sup> Ed., IEC 60079-1 7<sup>th</sup> Ed.,

IEC60079-7: 4<sup>th</sup> Ed., IEC 60079-31: 2<sup>nd</sup> Ed.

### **Specific Conditions of Use:**

1. The Modular Visual Strobe has external non-metallic surfaces which may provide a potential electrostatic charging hazard. See the manufacturer's instructions for further information.
2. The Modular Visual Strobe has metallic components in the non-metallic walls of the enclosure which can store electrical charge and therefore may provide a potential electrostatic charging hazard. The metallic brass inserts have a capacitance of 14 pF. The metallic guard has a capacitance of 18 pF. See the manufacturer's instructions for further information.

### **cULus Zone Certifications:**

Models that contain the Ex e increased safety (E-box) are not cULus Zone certified and not suitable for use in Class, Zone locations. Only the following models are certified: G-STR-120-D-x, G-STR-120-T-x, G-STR-230-D-x, G-STR-230-T-x, G-STR-024-D-x, and G-STR-024-T-x. Please disregard any references to the E-box when using these instructions for Class, Zone installations

These models use protections:

Class I, Zone 1, A Ex db IIC T3

Zone 21, AEx tb IIIC T3/200°C IP66 (Tamb= -55°C to +70°C)

Ex db IIC T3

Ex tb IIIC T3/200°C IP66 (Tamb= -55°C to +70°C)

### **Unpacking the Beacon**

#### **⚠ WARNING**

***EXPLOSION HAZARD: A damaged lens can lead to explosions, causing serious injury or death. If a lens is damaged, it must be replaced.***

After unpacking the beacon, examine it for damage that may have occurred in transit. If it has been damaged, do not attempt to install or operate it. File a claim immediately with the carrier, stating the extent

## ***Installation and Maintenance Instructions***

---

of the damage. Carefully check all envelopes, shipping labels, and tags before removing or discarding them. Disposal of all shipping materials must be carried out in accordance with national and local codes and standards. If any parts are missing, please call Federal Signal Customer Support at +1 708-534-4756 or +1 877-289-3246.

### **Creating Combination Fixtures in the Field**

The Federal Signal Global Series Ex de products can be connected together in the field using interchangeable E-box end caps and a proprietary coupling system. The proprietary coupling system allows for simple, and cost effective, wiring from product to product, often eliminating the need for expensive Ex wiring practices and Ex rated glands. The E-box is available only when factory installed on an Ex d unit or when used as a E-box spacer adjoining an existing E-box. Refer to the accessories listed on page 24 for available options. When creating certain fixture combinations, it is necessary to replace the E-box end caps before mounting the product. If you are creating combination fixtures, refer to instruction manual 25500259 for specific instructions and details.

A note about combination fixtures: If the product is Ex db marked, it is for use in gas atmospheres. If the product is Ex db e marked, it uses increased-safety terminal enclosures and is for use in gas atmospheres. The product is Ex tb marked for use in dust atmospheres.

**Figure 1** Beacon and sounder combination fixture



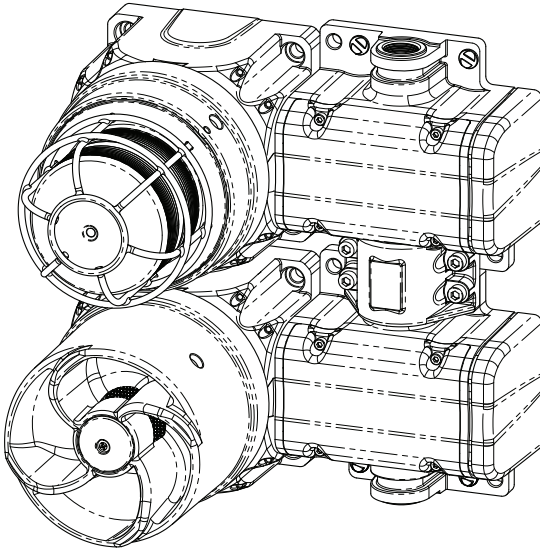

## Mounting the Beacon

**⚠ WARNING**

**ATTACH THE BEACON SECURELY:** To prevent injury, this apparatus must be securely attached to the mounting surface in accordance with the installation instructions. Use installer-supplied fasteners suitable for the mounting surface.

The mounting method and the installer-supplied mounting hardware depend on which of the two G-STR models you are installing:

### **Mounting the Surface-Mount Ex d Beacon**

Mount the beacon to a flat surface using the four 8.5 mm mounting holes. Use installer-supplied fasteners suitable for the surface to which the device will be mounted.

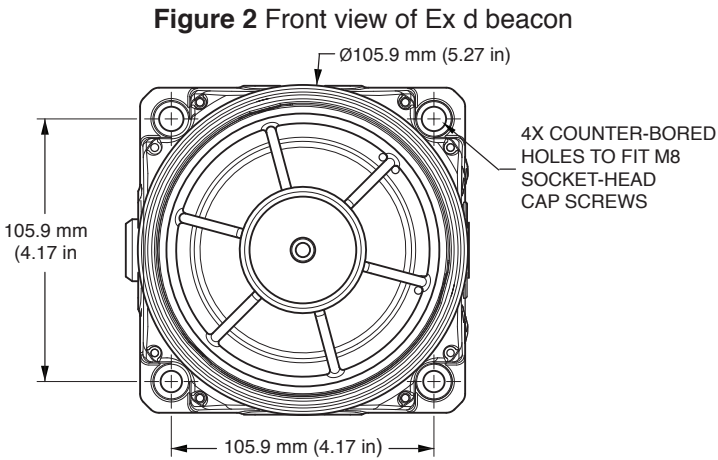

**Figure 3** Side view of Ex d beacon

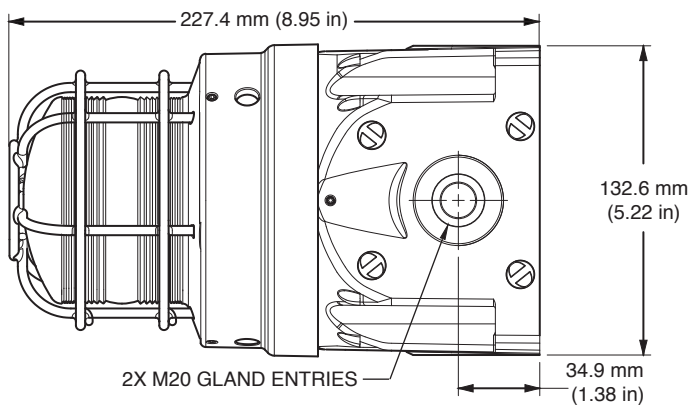

**Mounting the Ex de Surface-Mount Beacon**

Mount the beacon to a flat surface using the six 8.5 mm mounting holes. Use installer-supplied fasteners suitable for the surface to which the device will be mounted.

**Figure 4** Front view of Ex de surface mount

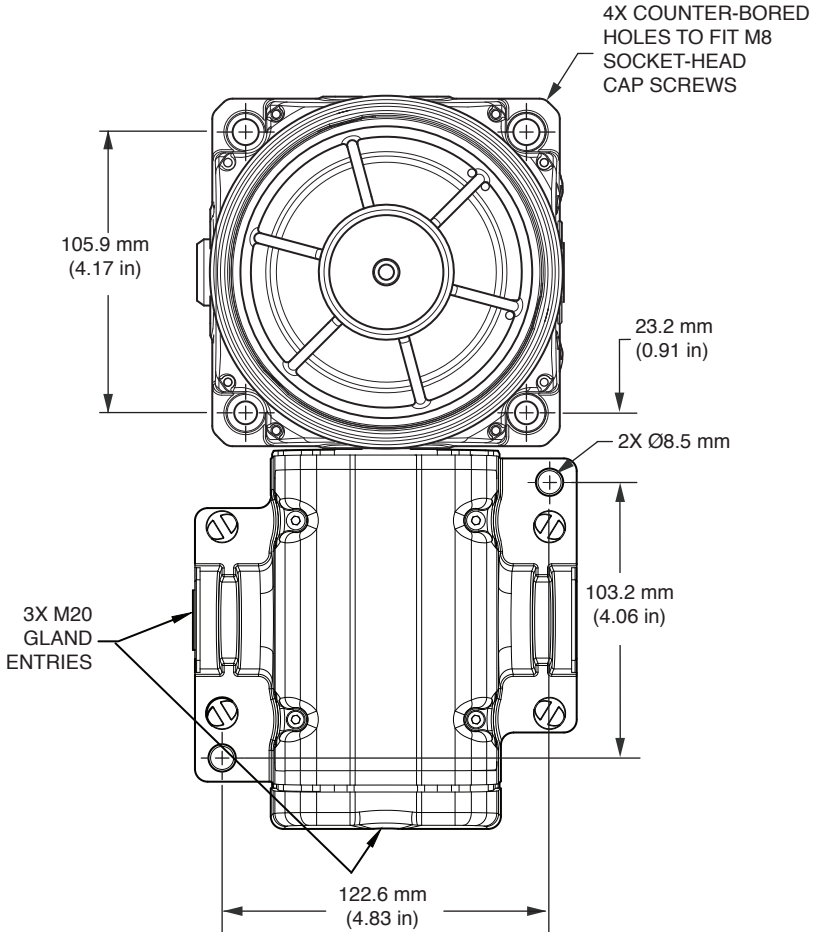

**Figure 5** Side view of Ex de surface mount

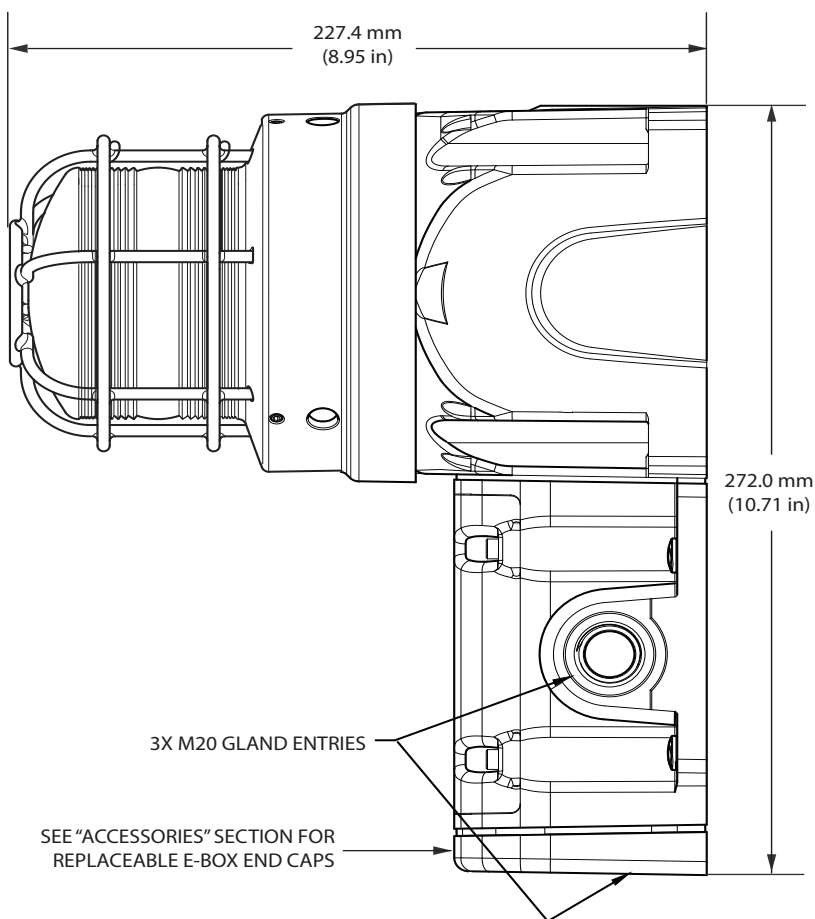

### **Safety Messages for Wiring**

When installing and operating flame-proof electrical equipment, the relevant national regulations for installation and operation (e.g., EN60079-14, IEC Wiring Regulations and NEC/CEC) must be observed.

- To avoid electrical shock hazards, do not connect wires when power is applied. Failure to observe this warning may lead to serious injury or death.
- To maintain the flame-proof integrity of the enclosure, **DO NOT** damage the strobe lens cover or threads while disassembling or reassembling unit.
- Painting and surface finishes, other than those applied by Federal Signal Corporation, are not permitted.
- Cable termination should be in accordance with specifications applying to the application. Federal Signal recommends that all cables and cores should be fully identified.
- Ensure that only the correct equipment-certified glands are used and that the assembly is shrouded and correctly earthed. Gland entries are M20-1.5 6H with an option for the M25 entry on the end of the increased safety box models. See Table 3 on page 24 for choosing the correct cable entry devices for Equipment in Potentially Explosive Atmospheres.
- Because of space limitations, ensure the cable cores within the unit are not too slack.
- In all countries, the wiring must comply with all national and local codes and standards.
- Ensure that all nuts, bolts, and fixings are secure.

## Preparing to Wire the Ex d Flameproof Models

### **⚠ WARNING**

**SHOCK HAZARD:** To avoid electrical shock hazards, do not connect wires when power is applied. Failure to observe this warning may lead to serious injury or death.

### **NOTICE**

**CIRCUIT BOARD DAMAGE:** The DC units are polarity sensitive, and **MAY BE DAMAGED** by incorrect electrical hookup. When connecting the DC strobe unit to the voltage supply lines, **POLARITY MUST BE OBSERVED**. In addition, damage will result if the voltage rating of the particular model is exceeded by more than 10 percent.

This section has wiring instructions for the three flameproof models:

- G-STR 24 Vdc
- G-STR 120 Vac
- G-STR 220-240 Vac

Ex d units are supplied with a six-position, PCB mounted, screw-terminal block. The maximum wire gauge is 4.0 mm<sup>2</sup> (12 AWG). The wire must be rated 85 °C or higher. Use only stranded cable to terminate the beacon. The cross-sectional area of the primary earth (ground) must equal the cross-sectional area of the phase conductor.

Cable termination for these models should be in accordance with specifications applying to the application. It is recommended that all cables and cores should be fully identified. Use the appropriate cable gland for the application. Gland entry threads are M20-1.5 x 6H.

### **Tools needed:**

- 1.5 mm A/F hexagon key
- 2 mm flat-tip screwdriver
- No. 1 Phillips screwdriver
- Wire stripper

### Wiring the Ex d Models

To wire the Ex d models:

1. Unscrew the M3 hex set screw on the side of the housing one full turn.
2. Remove the lens cover from the housing by turning the cover counter-clockwise. Three 120-degree spaced reliefs are provided for a 3/8 in spanner wrench if needed. If the cover will not unscrew, back out the set screw a few additional turns.
3. Loosen the captive Phillips screw retaining the printed circuit board (PCB).
4. Slide out the PCB until the terminals clear the housing. Strip the wire insulation 8 mm (0.31 in). Maximum screw-tightening torque is 0.6 Nm (5 in-lb).

#### 24 Vdc Models

- a. See Figure 6. Connect the positive (+) power source wire to the terminal-block screw marked **+**.
- b. Connect the negative (-) power source wire to the terminal block screw marked **-**.
- c. Connect the earth ground wire to the terminal block pole marked **-GND**.

**Figure 6** IN/OUT PCB connections for Ex d 24 Vdc

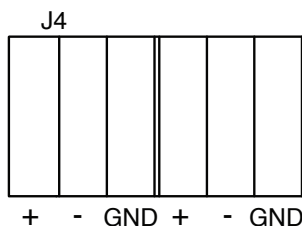

#### 120 Vac and 220-240 Vac Models

- a. See Figure 7 on page 17. Connect the line (hot) power source wire to the terminal-block screw marked **L1**.



- b. Connect the neutral (common) power source wire to the terminal block screw marked **L2**.
- c. Connect the earth ground wire to the terminal block pole marked **GND**.

**Figure 7** IN/OUT PCB connections for  
Ex d 120 Vac and 220-240 Vac

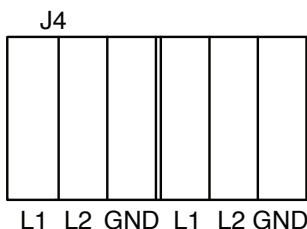

5. Insert the PCB into the enclosure and fully tighten the PCB captive screw.
6. Place the cover on the housing and tighten it by turning it clockwise.
7. To ensure O-ring compression, the cover must be fully seated against the housing when the threads are tightened. Turn the M3 set screw on the side of the housing until the screw contacts the housing.
8. Ensure that the unused wire entry is sealed with the provided brass M20-1.5 x 6 g stopping plug (equipment-certified).
9. Test the beacon for proper operation.

### Preparing to Wire the Ex de Increased Safety Models

**⚠ WARNING**

**SHOCK HAZARD:** To avoid electrical shock hazards, do not connect wires when power is applied. Failure to observe this warning may lead to serious injury or death.

This section has wiring instructions for the three increased safety models:

- G-STR 24 Vdc
- G-STR 120 Vac
- G-STR 220-240 Vac

## ***Installation and Maintenance Instructions***

---

Ex de units are supplied with a six-pole, spring tension-clamp style terminal block. The maximum wire gauge is 4.0 mm<sup>2</sup> (12 AWG). The wire must be rated 85 °C or higher. Use only stranded cable to terminate the beacon. The cross-sectional area of the primary earth (ground) must equal the cross-sectional area of the phase conductor.

Cable termination should be in accordance with specifications applying to the application. It is recommended that all cables and cores should be fully identified. Use the appropriate cable gland for the application. Gland entry threads are M20-1.5 6H.

Conductive metalwork, including cable glands, must be a minimum of 5 mm away from the terminals.

Leads connected to the terminals shall be insulated for the appropriate voltage and this insulation shall extend to within 1 mm of the metal of the terminal throat.

The G-STR terminal block is supplied with two conductors per pole. The terminal block allows for easy supply-in and loop-out wiring to connect beacons in series.

Tools needed:

- 3.0 mm A/F hexagon key
- No. 1 Phillips screwdriver
- Wire stripper

### **Wiring the Ex de Models**

#### **NOTICE**

***CIRCUIT BOARD DAMAGE: The DC units are polarity sensitive, and MAY BE DAMAGED by incorrect electrical hookup. When connecting the DC strobe unit to the voltage supply lines, POLARITY MUST BE OBSERVED. In addition, damage will result if the voltage rating of the particular model is exceeded by more than 10 percent.***

To wire the Ex de beacon:

1. Unscrew the four M4 socket-head cap screws and remove the terminal box cover.

- Strip the wire insulation 8 mm to 9 mm (0.33 in).

**NOTE:** When using more than one single or multiple strand lead, the connection on either side of any terminal must be joined in a suitable manner, e.g. two conductors into a single insulated crimped bootlace ferrule.

- To connect wires, press the pushbutton on the terminal block with a Phillips screwdriver and insert the wire into the round opening. Release the pushbutton to make connection.

### **24 Vdc Model**

- See Figure 8. Connect the positive (+) power source wire to the terminal block pole marked **L1/+**.

**Figure 8** Connections for DC or AC Ex de beacons

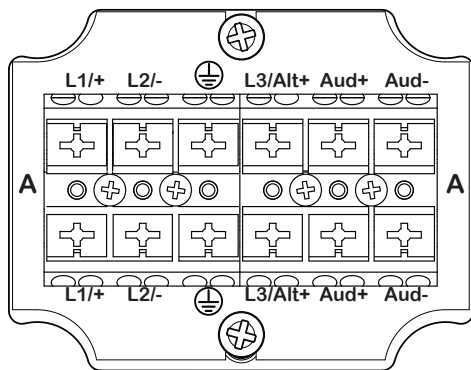

- Connect the negative (-) power source wire to the terminal block pole marked **L2/-**.
- Connect the earth ground wire to the terminal block pole marked  $\oplus$ .

### **120 Vac or 220-240 Vac Ex de Models**

- See Figure 8. Connect the line (hot) power-source wire to the terminal block pole marked **L1/+**.
- Connect the neutral (common) power source wire to the terminal block pole marked **L2/-**.

## ***Installation and Maintenance Instructions***

---

- c. Connect the ground wire to the terminal block pole marked .
4. Secure the cover on the terminal box with the four M4 screws. Ensure that the gasket is properly seated to maintain the IP rating. **Do not overtighten the screws.**
5. Test the beacon for proper operation.

### **Safety Messages to Maintenance Personnel**

#### **WARNING**

Listed below are some important safety instructions and precautions you should follow:

- Read and understand all instructions before operating this system.
- If you acquired a significant quantity of units, then it is recommended that spares are also made available.
- Any maintenance to the beacon system must be done with power turned off.
- Any maintenance to the beacon system must be performed by a trained electrician who is thoroughly familiar with all applicable national and local codes in the country of use.
- Never alter the unit in any manner. Safety of the unit may be affected if additional openings or other alterations are made to the internal components or housing.
- Repair of flamepaths is not intended.
- The nameplate, which may contain cautionary or other information of importance to maintenance personnel, should NOT be obscured in any way. Ensure that the nameplate remains readable.
- After performing any maintenance, test the beacon system to ensure that it is operating properly.

Failure to follow all safety precautions and instructions may result in property damage, serious injury, or death.

## Maintaining the Beacon

### **⚠ WARNING**

**EXPLOSION HAZARD:** *To prevent ignition of hazardous atmosphere, disconnect the beacon from the supply circuit before opening it. Do not open the beacon in the presence of explosive gases in the atmosphere. Failure to follow this warning may result in serious injury or death.*

During the working life of the beacon, it should require little or no maintenance. The non-metallic housing will resist attack by most acids, alkalis, and chemicals and is as resistant to concentrated acids and alkalis as most metal products. However, if abnormal or unusual environment conditions occur due to plant damage or accident, etc., visual inspection of the beacon is recommended.

### ***Cleaning the Enclosure***

The enclosure should be cleaned periodically with a damp cloth to maintain maximum light output. The polycarbonate colored strobe lens should be regularly inspected for cracks. If it is damaged, it must be replaced.

Refer to the “Certification” section on page 6 for any applicable Specific Conditions of Use.

### ***Replacing the Strobe Tube***

### **⚠ WARNING**

**EXPLOSION HAZARD:** *To maintain the flameproof integrity of the enclosure, DO NOT damage the lens or threads while disassembling or reassembling the beacon.*

### **⚠ WARNING**

**LIGHT HAZARD:** *To be an effective warning device, the beacon produces bright light that can be hazardous to your eyesight when viewed at close range. Do not stare directly into the beacon at close range or permanent damage to your eyesight may occur.*

### **⚠ CAUTION**

**BURN HAZARD:** *The strobe tube gets hot enough to burn you. Always allow the strobe to cool before handling it.*

### **⚠ CAUTION**

**DO NOT TOUCH STROBE TUBES WITH BARE HANDS:** *Oil deposits on the glass portion of the tube can cause the glass to fracture during use. If you are unsure whether the glass portion has been handled without gloves, clean the glass using a soft cloth and isopropyl alcohol before installing the lamp.*

### **NOTICE**

**STATIC SENSITIVE DEVICE:** *The circuitry of the beacon can be damaged by an electrostatic discharge (ESD). Always follow anti-static procedures while servicing the beacon.*

Tool and replacement part needed: 1.5 mm A/F hexagon key, and Federal Signal strobe tube part No. K8107177.

To replace the strobe tube:

1. Disconnect power to the beacon.
2. Use the hexagon key to unscrew the set screw on the housing one full turn.
3. Remove the cover from the housing by turning the cover counter-clockwise. If the strobe lens will not unscrew, back out the set screw a few additional turns.
4. Remove the strobe tube from the socket by pulling it up on the base using a gentle rocking motion.
5. Insert the new strobe tube into the socket. Ensure that the tube is fully seated.
6. Place the cover on the housing and tighten it by turning it clockwise.

7. To ensure O-ring compression, the cover must be fully seated against the housing when the threads are tightened. Turn the M3 set screw on the side of the housing until the screw contacts the housing.
8. Reconnect power to the beacon.
9. Apply power and verify that the beacon operates properly.

### ***Lubricating the Threaded Joints***

A silicone based, non-hardening, chemically compatible grease can be applied if required.

## **Ordering Accessories and Replacement Parts**

### **⚠ WARNING**

***EXPLOSION HAZARD: A damaged lens can lead to explosions, causing serious injury or death. If a lens is damaged, it must be replaced.***

Replacement parts and accessories are listed in Tables 1 and 2 on page 24. Due to certification, certain component parts are not available for field replacement. Beacons with this type of damage must be either replaced entirely or returned to Federal Signal for service.

Refer to instruction manual 25500259 for accessory and replacement part assembly and operating instructions.

To order, call Federal Signal Customer Support at 708-534-4756 or 877-289-3246.

**Table 1** Replacement parts

<b>Description</b>	<b>Part Number</b>
Lens Guard	K859500821-01
Lens, Amber	K859500814
Lens, Blue	K859500814-01
Lens, Clear	K859500814-02
Lens, Green	K859500814-03
Lens, Red	K859500814-04
Lens, Magenta	K859500814-05
Lens, Yellow	K859500814-06
Strobe Tube	K8107177
Circuit Board, 24 Vdc	K85951402-024
Circuit Board, 120 Vac	K85951402-120
Circuit Board, 220-240 Vac	K85951402-230

**Table 2** Accessories

<b>Description</b>	<b>Part Number</b>
Indicator Ring/Legend Kit, Black	G-KIT-RP-BK
Indicator Ring/Legend Kit, Blue	G-KIT-RP-B
Indicator Ring/Legend Kit, Green	G-KIT-RP-G
Indicator Ring/Legend Kit, Magenta	G-KIT-RP-M
Indicator Ring/Legend Kit, Red	G-KIT-RP-R
Indicator Ring/Legend Kit, Yellow	G-KIT-RP-Y
E-Box Coupler Kit	K859501228
E-Box End Cap, M20	K859500805-02
E-box End Cap, M20 with Flange	K859500805-03
In-Line E-Box Coupler Kit	G-KIT-EC180
90-Degree E-Box Coupler Kit	G-KIT-EC90
Extension Box Spacer Kit	G-KIT-EXTB
Single Trunnion Kit	G-KIT-ST
Dual Trunnion Kit	G-KIT-DT

**Table 3** Choosing cable-entry devices for Equipment



## ***Installation and Maintenance Instructions***

### in Potentially Explosive Atmospheres

<b>Models</b>	<b>Ex Atmospheres</b>	<b>Cable Entry Devices (cable glands, stopping plugs, etc.)</b>
G-STR-XXX-D-X (Ex db surface mount)	Gas	Cable entry devices shall be equipment certified as flameproof. To maintain the ingress protection of the flameproof beacon enclosure, we recommend the cable entry device be IP66 certified.
G-STR-XXX-E-X (Ex db surface mount)	Gas	For the flameproof beacon enclosure, cable entry devices shall be equipment certified as flameproof. To maintain the ingress protection of the flameproof beacon enclosure we recommend the cable entry device be IP66 certified. For the increased safety terminal enclosures (terminal boxes), cable entry devices shall be equipment certified as increased safety and shall maintain an IP rating of IP54.
G-STR-XXX-D-X (Ex db surface mount)  G-STR-XXX-E-X (Ex db e surface mount)	Dust	Cable entry devices for the Beacon and terminal enclosures shall be equipment certified as dust protected. To maintain the ingress protection of the beacon and terminal enclosures the cable entry devices shall be IP6X certified.

## **Getting Repair Service or Technical Assistance**

Products returned for repair require a Return Authorization form from your local distributor or from Federal Signal. To obtain repair service or technical assistance from Federal Signal, call 708-534-4756 or 877-289-3246.

## **Returning the Product for Credit**

Product returns for credit require a return authorization from your local distributor prior to returning the product to Federal Signal. Please contact your distributor for assistance.

A product is qualified to be returned for credit when the following conditions are met:

- The product is resalable and in the original cartons.
- The product has not been previously installed.
- The product is the current revision.
- The product has not been previously repaired.
- The product is a standard product.
- The product is not a service part.

All returns are subject to a re-stock fee.

Defective products that are returned within the warranty period will be repaired or replaced at Federal Signal's sole discretion. Defective products do not include those products with lamp failure.

Circumstances other than those listed above will be addressed on a case-by-case basis.

